



CE Radio Test Report

Project No. : 2405G097
Equipment : Projector
Brand Name : XGIMI
Test Model : XN13A
Series Model : N/A
Applicant : XGIMI Technology Co., Ltd.
Address : Building No.4, Zone A, No.1129, Shijicheng Road, Chengdu High-tech Zone, Sichuan Pilot Free Trade Zone, China
Manufacturer : XGIMI Technology Co., Ltd.
Address : Building No.4, Zone A, No.1129, Shijicheng Road, Chengdu High-tech Zone, Sichuan Pilot Free Trade Zone, China
Factory : Yibin XGIMI Optoelectronic Co., Ltd.
Address : No. 2, West Section 4, Changjiang North Road, Lingang Economic Development Zone, Yibin City, Sichuan P.R. China
Date of Receipt : May 31, 2024
Date of Test : Jun. 06, 2024 ~ Jul. 11, 2024
Issued Date : Jul. 19, 2024
Report Version : R00
Test Sample : Engineering Sample No.: SSL2024053139 for radiated, SSL2024053135 for adaptivity, SSL2024053136 for others.
Standard(s) : ETSI EN 300 328 V2.2.2 (2019-07)

The above equipment has been tested and found compliance with the requirement of the relative standards by BTL Inc.

Prepared by : Sheldon Ou
Sheldon Ou

Approved by : Chay Cai
Chay Cai

Room 108, Building 2, No.1, Yile Road, Songshan Lake Zone, Dongguan City, Guangdong, People's Republic of China.

Tel: +86-769-8318-3000 Web: www.newbtl.com Service mail: btl_qa@newbtl.com

Declaration

BTL represents to the client that testing is done in accordance with standard procedures as applicable and that test instruments used has been calibrated with standards traceable to international standard(s) and/or national standard(s).

BTL's reports apply only to the specific samples tested under conditions. It is manufacture's responsibility to ensure that additional production units of this model are manufactured with the identical electrical and mechanical components. **BTL** assumes no responsibility for the data provided by the customer, any statements, inferences or generalizations drawn by the customer or others from the reports issued by **BTL**.

The report must not be used by the client to claim product certification, approval, or endorsement by A2LA or any agency of the U.S. Government.

This report is the confidential property of the client. As a mutual protection to the clients, the public and ourselves, the test report shall not be reproduced, except in full, without our written approval.

BTL's laboratory quality assurance procedures are in compliance with the ISO/IEC 17025: 2017 requirements, and accredited by the conformity assessment authorities listed in this test report.

BTL is not responsible for the sampling stage, so the results only apply to the sample as received.

The information, data and test plan are provided by manufacturer which may affect the validity of results, so it is manufacturer's responsibility to ensure that the apparatus meets the essential requirements of applied standards and in all the possible configurations as representative of its intended use.

Limitation

For the use of the authority's logo is limited unless the Test Standard(s)/Scope(s)/Item(s) mentioned in this test report is (are) included in the conformity assessment authorities acceptance respective.

Please note that the measurement uncertainty is provided for informational purpose only and are not use in determining the Pass/Fail results.

Table of Contents	Page
REPORT ISSUED HISTORY	7
1 . RF EMISSIONS MEASUREMENT	8
1.1 TEST FACILITY	8
1.2 MEASUREMENT UNCERTAINTY	8
1.3 TEST ENVIRONMENT CONDITIONS	8
1.4 TEST CHANNEL	9
1.5 TEST METHODOLOGY AND RESULT	10
2 . GENERAL INFORMATION	11
2.1 GENERAL DESCRIPTION OF EUT	11
2.2 DESCRIPTION OF TEST MODES	13
2.3 TABLE OF PARAMETERS OF TEST SOFTWARE SETTING	13
2.4 BLOCK DIAGRAM SHOWING THE CONFIGURATION OF SYSTEM TESTED	14
2.5 DESCRIPTION OF SUPPORT UNITS	14
2.6 CUSTOMER INFORMATION DESCRIPTION	14
3 . RF OUTPUT POWER	15
3.1 APPLIED PROCEDURES / LIMIT	15
3.2 TEST PROCEDURES	15
3.3 TEST SETUP LAYOUT	15
3.4 TEST DEVIATION	15
3.5 EUT OPERATION DURING TEST	15
3.6 TEST RESULTS	15
4 . POWER SPECTRAL DENSITY	16
4.1 APPLIED PROCEDURES / LIMIT	16
4.2 TEST PROCEDURES	16
4.3 TEST SETUP LAYOUT	16
4.4 TEST DEVIATION	16
4.5 EUT OPERATION DURING TEST	16
4.6 TEST RESULTS	16
5 . DUTY CYCLE, TX-SEQUENCE, TX-GAP	17
5.1 APPLIED PROCEDURES / LIMIT	17
5.2 TEST PROCEDURES	17
5.3 TEST SETUP LAYOUT	17

Table of Contents	Page
5.4 TEST DEVIATION	17
5.5 EUT OPERATION DURING TEST	17
5.6 TEST RESULTS	17
6 . MEDIUM UTILIZATION (MU) FACTOR	18
6.1 APPLIED PROCEDURES / LIMIT	18
6.2 TEST PROCEDURES	18
6.3 TEST SETUP LAYOUT	18
6.4 TEST DEVIATION	18
6.5 EUT OPERATION DURING TEST	18
6.6 TEST RESULTS	18
7 . ADAPTIVITY (ADAPTIVE EQUIPMENT USING MODULATIONS OTHER THAN FHSS)	19
7.1 APPLIED PROCEDURES / LIMIT	19
7.2 TEST PROCEDURES	23
7.3 TEST SETUP LAYOUT	23
7.4 TEST DEVIATION	23
7.5 EUT OPERATION DURING TEST	23
7.6 TEST RESULTS	23
8 . OCCUPIED CHANNEL BANDWIDTH	24
8.1 APPLIED PROCEDURES / LIMIT	24
8.2 TEST PROCEDURES	24
8.3 TEST SETUP LAYOUT	24
8.4 TEST DEVIATION	24
8.5 EUT OPERATION DURING TEST	24
8.6 TEST RESULTS	24
9 . TRANSMITTER UNWANTED EMISSIONS IN THE OUT-OF-BAND DOMAIN	25
9.1 APPLIED PROCEDURES / LIMIT	25
9.2 TEST PROCEDURES	25
9.3 TEST SETUP LAYOUT	25
9.4 TEST DEVIATION	25
9.5 EUT OPERATION DURING TEST	25
9.6 TEST RESULTS	25
10 . TRANSMITTER UNWANTED EMISSIONS IN THE SPURIOUS DOMAIN	26

Table of Contents	Page
10.1 APPLIED PROCEDURES / LIMIT	26
10.2 TEST PROCEDURES	26
10.3 TEST SETUP LAYOUT	27
10.4 TEST DEVIATION	27
10.5 EUT OPERATION DURING TEST	27
10.6 TEST RESULTS	27
11 . RECEIVER SPURIOUS EMISSIONS	28
11.1 APPLIED PROCEDURES / LIMIT	28
11.2 TEST PROCEDURES	28
11.3 TEST SETUP LAYOUT	28
11.4 TEST DEVIATION	28
11.5 EUT OPERATION DURING TEST	28
11.6 TEST RESULTS	28
12 . RECEIVER BLOCKING	29
12.1 APPLIED PROCEDURES / LIMIT	29
12.2 TEST PROCEDURES	30
12.3 TEST SETUP LAYOUT	30
12.4 TEST DEVIATION	30
12.5 EUT OPERATION DURING TEST	30
12.6 TEST RESULTS	30
13 . MEASUREMENT INSTRUMENTS LIST	31
14 . EUT TEST PHOTO	34
APPENDIX A - RF OUTPUT POWER	35
APPENDIX B - POWER SPECTRAL DENSITY	38
APPENDIX C - DUTY CYCLE, TX-SEQUENCE, TX-GAP	47
APPENDIX D - MEDIUM UTILIZATION (MU) FACTOR	48
APPENDIX E - ADAPTIVITY	49
APPENDIX F - OCCUPIED CHANNEL BANDWIDTH	71
APPENDIX G - TRANSMITTER UNWANTED EMISSIONS IN THE OOB DOMAIN	76
APPENDIX H - TRANSMITTER UNWANTED EMISSIONS IN THE SPURIOUS DOMAIN	81

Table of Contents	Page
APPENDIX I - RECEIVER SPURIOUS EMISSIONS	102
APPENDIX J - RECEIVER BLOCKING	111
APPENDIX K - INFORMATION AS REQUIRED BY EN 300 328 V2.2.2, CLAUSE 5.4.1	113

REPORT ISSUED HISTORY

Report No.	Version	Description	Issued Date	Note
BTL-ETSP-3-2405G097	R00	Original Report.	Jul. 19, 2024	Valid

1. RF EMISSIONS MEASUREMENT

1.1 TEST FACILITY

The test facilities used to collect the test data in this report is **DG-CB15/TR15/TR17** at the location of No.3, Jinshagang 1st Road, Dalang, Dongguan City, Guangdong People's Republic of China.

1.2 MEASUREMENT UNCERTAINTY

The measurement uncertainty figures shall be calculated according the methods described in the ETSI TR 100 028 and shall correspond to an expansion factor (coverage factor) $k=1.96$ or $k=2$ (which provide confidence levels of respectively 95% and 95.45% in the case where the distributions characterizing the actual measurement uncertainties are normal (Gaussian)).

Measurement Uncertainty for a Level of Confidence of 95.45%, $U=2 \times u_c(y)$.

The BTL measurement uncertainty as below table:

Parameter	Uncertainty
Output Power	1.3 dB
Occupied Channel Bandwidth	0.90 %
Power Spectral Density	1.4 dB
Conducted Spurious Emission	1.9 dB
Spurious Emissions, Radiated $f \leq 1\text{GHz}$	3.50 dB
Spurious Emissions, Radiated $1\text{GHz} < f \leq 12.75\text{GHz}$	3.54 dB
Temperature	0.8 °C
Supply voltages	3 %
Time	5 %

1.3 TEST ENVIRONMENT CONDITIONS

Test Item	Temperature	Humidity	Test Voltage	Tested By	Test Date
RF Output Power	Normal & Extreme	52%	DC 12V	Alex Yin	Jun. 24, 2024
Power Spectral Density	24°C	50%	DC 12V	Complex Qin	Jun. 25, 2024
Adaptivity	22°C	57%	DC 12V	Complex Qin	Jul. 09, 2024
Occupie Channel Bandwidth	24°C	50%	DC 12V	Complex Qin	Jun. 25, 2024
Transmitter unwanted emissions in the OOB domain	24°C	50%	DC 12V	Complex Qin	Jun. 25, 2024
Transmitter unwanted emissions in the spurious domain	25°C	45%	AC 230V/50Hz	Meers Zhang	Jul. 01, 2024-Jul. 02, 2024
Receiver spurious emissions	23-25°C	45-51%	AC 230V/50Hz	Meers Zhang	Jul. 01, 2024-Jul. 02, 2024
Receiver Blocking	23°C	56%	DC 12V	Complex Qin	Jul. 04, 2024

1.4 TEST CHANNEL

IEEE 802.11b / IEEE 802.11g / IEEE 802.11n(HT20)		
Test Channel	EUT Channel	Test Frequency
low	CH01	2412 MHz
middle	CH07	2442 MHz
high	CH11	2462 MHz

IEEE 802.11n(HT40)		
Test Channel	EUT Channel	Test Frequency
low	CH03	2422 MHz
middle	CH07	2442 MHz
high	CH09	2452 MHz

Note:

- (1) The technical requirements of the present document apply under the environmental profile for operation of the equipment, which shall be stated by the supplier.

1.5 TEST METHODOLOGY AND RESULT

Harmonised Standard ETSI EN 300 328					
Essential Requirement			Requirement Conditionality		Result
No	Description	Reference: Clause No	U/C	Condition	
1	RF Output Power	4.3.1.2 or 4.3.2.2	U	-	Pass
2	Power Spectral Density	4.3.2.3	C	Only for non-FHSS equipment	Pass
3	Duty cycle, Tx-Sequence, Tx-gap	4.3.1.3 or 4.3.2.4	C	Only for non-Adaptive equipment	N/A
4	Accumulated Transmit time, Frequency Occupation & Hopping Sequence	4.3.1.4	C	Only for FHSS equipment	N/A
5	Hopping Frequency Separation	4.3.1.5	C	Only for FHSS equipment	N/A
6	Medium Utilization	4.3.1.6 or 4.3.2.5	C	Only for non-Adaptive equipment	N/A
7	Adaptivity	4.3.1.7 or 4.3.2.6	C	Only for Adaptive equipment	Pass
8	Occupied Channel Bandwidth	4.3.1.8 or 4.3.2.7	U	-	Pass
9	Transmitter unwanted emissions in the OOB domain	4.3.1.9 or 4.3.2.8	U	-	Pass
10	Transmitter unwanted emissions in the spurious domain	4.3.1.10 or 4.3.2.9	U	-	Pass
11	Receiver spurious emissions	4.3.1.11 or 4.3.2.10	U	-	Pass
12	Receiver Blocking	4.3.1.12 or 4.3.2.11	U	-	Pass
13	Geo-location capability	4.3.1.13 or 4.3.2.12	C	Only for equipment with geo-location capability	N/A

Note:

- (1) "U/C": Indicates whether the requirement is unconditionally applicable (U) or is conditional upon the manufacturer's claimed functionality of the equipment (C).

2. GENERAL INFORMATION

2.1 GENERAL DESCRIPTION OF EUT

Equipment	Projector
Brand Name	XGIMI
Test Model	XN13A
Series Model	N/A
Model Difference(s)	N/A
Hardware Version	V06
Software Version	V0.0.75
Power Source	DC voltage supplied from AC adapter. Model: S065ARV2000325
Power Rating	I/P: 100-240V~ 50/60Hz 1.8A Max O/P: 5.0V===3.0A 15.0W or 9.0V===3.0A 27.0W or 12.0V===3.0A 36.0W or 15.0V===3.0A 45.0W or 20.0V===3.25A 65.0W
Operation Frequency	2412 MHz ~ 2462 MHz
Modulation Technology	IEEE 802.11b: DSSS IEEE 802.11g: OFDM IEEE 802.11n: OFDM
Bit Rate of Transmitter	IEEE 802.11b: 11/5.5/2/1 Mbps IEEE 802.11g: 54/48/36/24/18/12/9/6 Mbps IEEE 802.11n: up to 300 Mbps
Max. e.i.r.p.	IEEE 802.11b: 17.80 dBm (60.26 mW) IEEE 802.11g: 19.80 dBm (95.50 mW) IEEE 802.11n(HT20): 19.51 dBm (89.33 mW) IEEE 802.11n(HT40): 19.66 dBm (92.47 mW)
Categorization	<input checked="" type="checkbox"/> Receiver category 1 <input type="checkbox"/> Receiver category 2 <input type="checkbox"/> Receiver category 3

Note:

1. For a more detailed features description, please refer to the manufacturer's specifications or the user's manual.

2. Channel List:

CH01 – CH11 for IEEE 802.11b, IEEE 802.11g, IEEE 802.11n(HT20) CH03 – CH09 for IEEE 802.11n(HT40)					
Channel	Frequency (MHz)	Channel	Frequency (MHz)	Channel	Frequency (MHz)
01	2412	06	2437	11	2462
02	2417	07	2442		
03	2422	08	2447		
04	2427	09	2452		
05	2432	10	2457		

3. Table for Filed Antenna:

Ant.	Brand	Model Name	Antenna Type	Connector	Gain (dBi)
1	ZTX	N/A	FPC	N/A	3.70
2	ZTX	N/A	FPC	N/A	4.15

Note:

This EUT supports CDD. Physically, the EUT provides two completed transmitters and receivers (2T2R).

4. The worst case for 1TX/2TX as follow:

Operating Mode	TX Mode	1TX	2TX
	IEEE 802.11b	V (Ant. 1)	-
	IEEE 802.11g	V (Ant. 1)	-
	IEEE 802.11n(HT20)	-	V (Ant. 1+Ant. 2)
	IEEE 802.11n(HT40)	-	V (Ant. 1+Ant. 2)

2.2 DESCRIPTION OF TEST MODES

To investigate the maximum EMI emission characteristics generated from EUT, the test system was pre-scanning tested based on the consideration of following EUT operation mode or test configuration mode which possibly have effect on EMI emission level. Each of these EUT operation mode(s) or test configuration mode(s) mentioned above was evaluated respectively.

Test Items	Mode / Modulation Type	Data Rate	Channel
RF Output Power	IEEE 802.11b/CCK	1 Mbps	01/07/11
	IEEE 802.11g/BPSK	6 Mbps	01/07/11
Power Spectral Density	IEEE 802.11n(HT20)/BPSK	MCS 0	01/07/11
	IEEE 802.11n(HT40)/BPSK	MCS 0	03/07/09
Adaptivity	IEEE 802.11b/CCK	1 Mbps	01/11
Occupied Channel Bandwidth	IEEE 802.11g/BPSK	6 Mbps	01/11
	IEEE 802.11n(HT20)/BPSK	MCS 0	01/11
Transmitter unwanted emissions in the OOB domain	IEEE 802.11n(HT40)/BPSK	MCS 0	03/09
	IEEE 802.11g/BPSK	6 Mbps	01/11
Transmitter unwanted emissions in the spurious domain (1 GHz ~ 12.75 GHz)	IEEE 802.11b/CCK	1 Mbps	01/11
	IEEE 802.11g/BPSK	6 Mbps	01/11
	IEEE 802.11n(HT20)/BPSK	MCS 0	01/11
	IEEE 802.11n(HT40)/BPSK	MCS 0	03/09
Receiver spurious emissions (30 MHz ~ 1 GHz)	IEEE 802.11g/BPSK	6 Mbps	01/11
Receiver spurious emissions (1 GHz ~ 12.75 GHz)	IEEE 802.11g/BPSK	6 Mbps	01/11
Receiver Blocking	IEEE 802.11b/CCK	1 Mbps	01/11

Note:

For radiated spurious emissions below 1 GHz and receiver spurious emissions above 1 GHz test, the IEEE 802.11g channel 01/11 are found to be the worst case and recorded.

2.3 TABLE OF PARAMETERS OF TEST SOFTWARE SETTING

During testing channel & power controlling software provided by the customer was used to control the operating channel as well as the output power level.

Test Software Version	WIFI_customer_package_Ulv2.06		
Frequency (MHz)	2412	2442	2462
IEEE 802.11b	16	15	15
IEEE 802.11g	1F	1F	1F
IEEE 802.11n(HT20)	19	19	19
Frequency (MHz)	2422	2442	2452
IEEE 802.11n(HT40)	1B	1B	1B

2.4 BLOCK DIAGRAM SHOWING THE CONFIGURATION OF SYSTEM TESTED

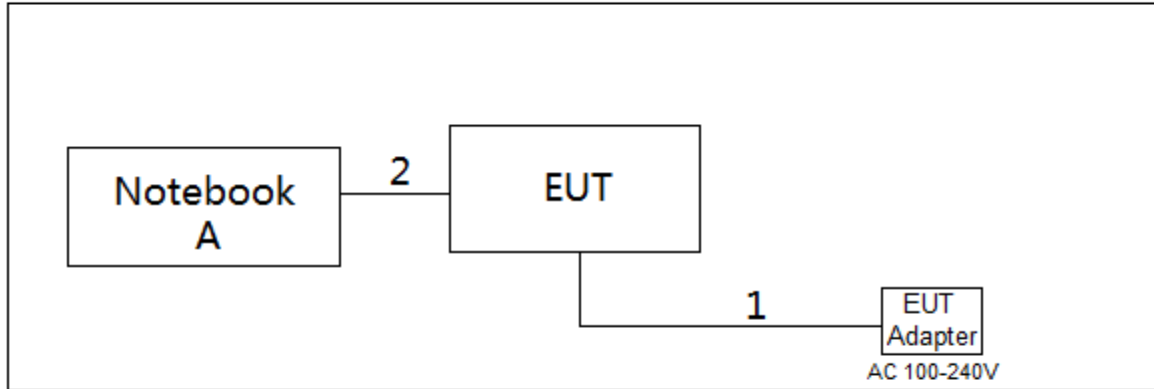

2.5 DESCRIPTION OF SUPPORT UNITS

The EUT has been tested as an independent unit together with other necessary accessories or support units. The following support units or accessories were used to form a representative test configuration during the tests.

Item	Equipment	Brand	Model No.	Series No.
A	Notebook	Huawei	NbDE-WFH9	N/A

Item	Cable Type	Shielded Type	Ferrite Core	Length
1	DC Cable	NO	NO	1.5m
2	USB Cable	NO	NO	0.5m

2.6 CUSTOMER INFORMATION DESCRIPTION

- 1) The antenna gain is provided by the manufacturer.
- 2) Except for radiated spurious emissions, the results of all test items include cable losses. Part of the cable losses (0.5dB) are provided by the manufacturer, while the other parts of the cable losses are provided by the testing laboratory.

3. RF OUTPUT POWER

3.1 APPLIED PROCEDURES / LIMIT

Clause	4.3.2.2
Test Item	RF output power
Limit	<p>The RF output power for non-FHSS equipment shall be equal to or less than 20 dBm.</p> <p>NOTE: For Non-adaptive FHSS equipment, the manufacturer may have declared a reduced RF Output Power (see clause 5.4.1 m) and associated Duty Cycle (see clause 5.4.1 e) that will ensure that the equipment meets the requirement for the Medium Utilization (MU) factor further described in clause 4.3.2.5. This is verified by the conformance test referred to in clause 4.3.2.5.4.</p> <p>For non-adaptive non-FHSS equipment, where the manufacturer has declared an RF output power of less than 20 dBm e.i.r.p., the RF output power shall be equal to or less than that declared value.</p> <p>This limit shall apply for any combination of power level and intended antenna assembly.</p>

3.2 TEST PROCEDURES

Refer to ETSI EN 300 328, chapter 5.4.2.2.1.

3.3 TEST SETUP LAYOUT

Normal Condition



Extreme Condition

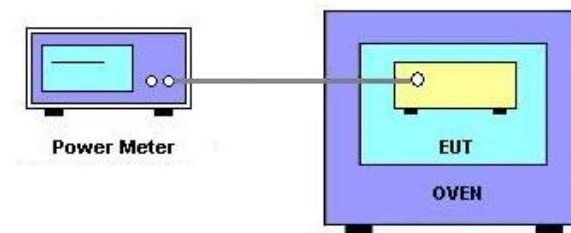

3.4 TEST DEVIATION

There is no deviation with the original standard.

3.5 EUT OPERATION DURING TEST

The measurements shall be performed during continuously transmitting.

3.6 TEST RESULTS

Please refer to the Appendix A.

4. POWER SPECTRAL DENSITY

4.1 APPLIED PROCEDURES / LIMIT

Clause	4.3.2.3
Test Item	Power Spectral Density
Limit	The maximum Power Spectral Density for non-FHSS equipment is 10 dBm per MHz.

4.2 TEST PROCEDURES

Refer to ETSI EN 300 328, chapter 5.4.3.2.1.

4.3 TEST SETUP LAYOUT

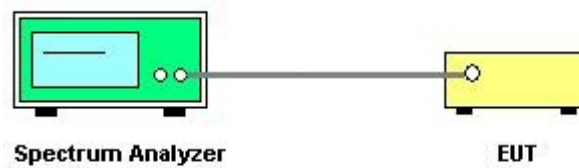

4.4 TEST DEVIATION

There is no deviation with the original standard.

4.5 EUT OPERATION DURING TEST

The measurements shall be performed during continuously transmitting.

4.6 TEST RESULTS

Please refer to the Appendix B.

5. DUTY CYCLE, TX-SEQUENCE, TX-GAP

5.1 APPLIED PROCEDURES / LIMIT

Clause	4.3.2.4
Test Item	Duty Cycle, Tx-sequence, Tx-gap
Limit	<p>Non-FHSS equipment shall comply with the following: The Duty Cycle shall be equal to or less than the maximum value declared by the manufacturer. The Tx-sequence time shall be equal to or less than 10 ms. The minimum Tx-gap time following a Tx-sequence shall be equal to the duration of that proceeding Txsequence with a minimum of 3,5 ms.</p> <p>NOTE: For Non-adaptive FHSS equipment, the manufacturer may have declared a reduced RF Output Power (see clause 5.4.1 m) and associated Duty Cycle (see clause 5.4.1 e) that will ensure that the equipment meets the requirement for the Medium Utilization (MU) factor further described in clause 4.3.2.5. This is verified by the conformance test referred to in clause 4.3.2.5.4.</p>

5.2 TEST PROCEDURES

Refer to ETSI EN 300 328, chapter 5.4.2.2.1.

5.3 TEST SETUP LAYOUT

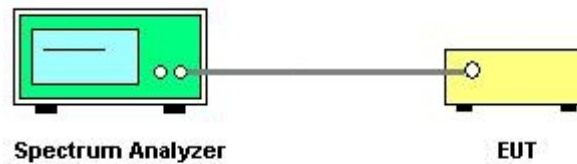

5.4 TEST DEVIATION

There is no deviation with the original standard.

5.5 EUT OPERATION DURING TEST

The measurements shall be performed during continuously transmitting.

5.6 TEST RESULTS

Please refer to the Appendix C.

6. MEDIUM UTILIZATION (MU) FACTOR

6.1 APPLIED PROCEDURES / LIMIT

Clause	4.3.2.5
Test Item	Medium Utilization (MU) factor
Limit	The maximum Medium Utilization factor for non-adaptive non-FHSS equipment shall be 10 %.

6.2 TEST PROCEDURES

Refer to ETSI EN 300 328, chapter 5.4.2.2.1.

6.3 TEST SETUP LAYOUT

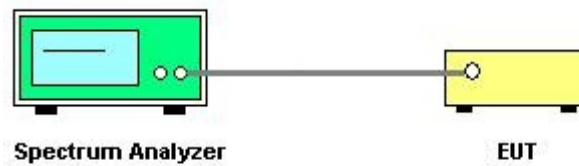

6.4 TEST DEVIATION

There is no deviation with the original standard.

6.5 EUT OPERATION DURING TEST

The measurements shall be performed during continuously transmitting.

6.6 TEST RESULTS

Please refer to the Appendix D.

7. ADAPTIVITY (ADAPTIVE EQUIPMENT USING MODULATIONS OTHER THAN FHSS)

7.1 APPLIED PROCEDURES / LIMIT

Clause	4.3.2.6						
Test Item	Adaptivity (adaptive equipment using modulations other than FHSS)						
Limit	<p>Adaptive non-FHSS using DAA</p> <p>Adaptive non-FHSS equipment using DAA shall comply with the following minimum set of requirements:</p> <ol style="list-style-type: none"> 1) During normal operation, the equipment shall evaluate the presence of a signal on its current operating channel(s). If it is determined that a signal is present with a level above the detection threshold defined in step 5 that channel shall be marked as 'unavailable'. 2) The channel(s) shall remain unavailable for a minimum time equal to 1 s after which the channel may be considered again as an 'available' channel. 3) The total time during which an equipment has transmissions on a given channel without re-evaluating the availability of that channel, is defined as the Channel Occupancy Time. The Channel Occupancy Time shall be less than 40 ms. Each such transmission sequence shall be followed by an Idle Period (no transmissions) of minimum 5 % of the Channel Occupancy Time with a minimum of 100 μs. After this, the procedure as in step 1 needs to be repeated. 4) The detection threshold shall be proportional to the transmit power of the transmitter: for a 20 dBm e.i.r.p. transmitter the detection threshold level (TL) shall be equal to or less than -70 dBm/MHz at the input to the receiver assuming a 0 dBi (receive) antenna assembly. This threshold level (TL) may be corrected for the (receive) antenna assembly gain (G); however, beamforming gain (Y) shall not be taken into account. For power levels less than 20 dBm e.i.r.p., the detection threshold level may be relaxed to: $TL = -70 \text{ dBm/MHz} + 10 \times \log_{10} (100 \text{ mW} / P_{\text{out}}) \text{ (} P_{\text{out}} \text{ in mW e.i.r.p.)}$ 5) The equipment shall comply with the requirements defined in step 1 to step 4 of the present clause in the presence of an unwanted CW signal as defined in table 9. <p style="text-align: center;">Table 9: Unwanted Signal parameters</p> <table border="1" style="width: 100%; border-collapse: collapse;"> <thead> <tr> <th style="text-align: center;">Wanted signal mean power from companion device (dBm)</th> <th style="text-align: center;">Unwanted signal frequency (MHz)</th> <th style="text-align: center;">Unwanted CW signal power (dBm)</th> </tr> </thead> <tbody> <tr> <td style="text-align: center;">-30 (see note 2)</td> <td style="text-align: center;">2 395 or 2 488,5 (see note 1)</td> <td style="text-align: center;">-35 (see note 2)</td> </tr> </tbody> </table> <p>NOTE 1: The highest frequency shall be used for testing operating channels within the range 2 400 MHz to 2 442 MHz, while the lowest frequency shall be used for testing operating channels within the range 2 442 MHz to 2 483,5 MHz. See clause 5.4.6.1.</p> <p>NOTE 2: The level specified is the level at the UUT receiver input assuming a 0 dBi antenna assembly gain. In case of conducted measurements, this level has to be corrected for the (in-band) antenna assembly gain (G). In case of radiated measurements, this level is equivalent to a power flux density in front of the UUT antenna.</p>	Wanted signal mean power from companion device (dBm)	Unwanted signal frequency (MHz)	Unwanted CW signal power (dBm)	-30 (see note 2)	2 395 or 2 488,5 (see note 1)	-35 (see note 2)
Wanted signal mean power from companion device (dBm)	Unwanted signal frequency (MHz)	Unwanted CW signal power (dBm)					
-30 (see note 2)	2 395 or 2 488,5 (see note 1)	-35 (see note 2)					

Limit	<p>Adaptive non-FHSS using LBT</p> <p>The present document defines two types of adaptive non-FHSS equipment that uses an LBT mechanism: Frame Based Equipment and Load Based Equipment. Adaptive non-FHSS equipment which is capable of operating as either Load Based Equipment or as Frame Based Equipment is allowed to switch dynamically between these types of operation.</p> <p>a. Frame Based Equipment</p> <p>Frame Based Equipment shall comply with the following requirements:</p> <ol style="list-style-type: none"> 1) Before transmission, the equipment shall perform a Clear Channel Assessment (CCA) check using energy detect. The equipment shall observe the operating channel for the duration of the CCA observation time which shall be not less than 18 μs. The channel shall be considered occupied if the energy level in the channel exceeds the threshold given in step 5 below. If the equipment finds the channel to be clear, it may transmit immediately. See figure 2. 2) If the equipment finds the channel occupied, it shall not transmit on this channel during the next Frame Period. The equipment is allowed to switch to a non-adaptive mode and to continue transmissions on this channel providing it complies with the requirements applicable to non-adaptive equipment. See clause 4.3.2.6.1. Alternatively, the equipment is also allowed to continue Short Control Signalling Transmissions on this channel providing it complies with the requirements given in clause 4.3.2.6.4. 3) The total time during which an equipment has transmissions on a given channel without re-evaluating the availability of that channel, is defined as the Channel Occupancy Time. The Channel Occupancy Time shall be in the range 1 ms to 10 ms followed by an Idle Period of at least 5 % of the Channel Occupancy Time used in the equipment for the current Frame Period. See figure 2. 4) An equipment, upon correct reception of a transmission which was intended for this equipment can skip CCA and immediately (see also next paragraph) proceed with the transmission of management and control frames. A consecutive sequence of such transmissions by the equipment without a new CCA shall not exceed the maximum Channel Occupancy Time. For the purpose of multi-cast, the ACK transmissions (associated with the same data packet) of the individual devices are allowed to take place in a sequence. 5) The energy detection threshold for the CCA shall be proportional to the transmit power of the transmitter: for a 20 dBm e.i.r.p. transmitter the CCA threshold level (TL) shall be equal to or less than -70 dBm/MHz at the input to the receiver assuming a 0 dBi (receive) antenna assembly. This threshold level (TL) may be corrected for the (receive) antenna assembly gain (G); however, beamforming gain (Y) shall not be taken into account. For power levels less than 20 dBm e.i.r.p. the CCA threshold level may be relaxed to: $TL = -70 \text{ dBm/MHz} + 10 \times \log_{10} (100 \text{ mW}/P_{\text{out}}) \text{ (} P_{\text{out}} \text{ in mW e.i.r.p.)}$
-------	---

6) The equipment shall comply with the requirements defined in step 1 to step 4 in the present clause in the presence of an unwanted CW signal as defined in table 10.

Table 10: Unwanted Signal parameters

Wanted signal mean power from companion device	Unwanted signal frequency (MHz)	Unwanted signal power (dBm)
sufficient to maintain the link (see note 2)	2 395 or 2 488,5 (see note 1)	-35 (see note 3)
NOTE 1: The highest frequency shall be used for testing operating channels within the range 2 400 MHz to 2 442 MHz, while the lowest frequency shall be used for testing operating channels within the range 2 442 MHz to 2 483,5 MHz. See clause 5.4.6.1. NOTE 2: A typical conducted value which can be used in most cases is -50 dBm/MHz. NOTE 3: The level specified is the level at the UUT receiver input assuming a 0 dBi antenna assembly gain. In case of conducted measurements, this level has to be corrected for the (in-band) antenna assembly gain (G). In case of radiated measurements, this level is equivalent to a power flux density in front of the UUT antenna.		

b. Load Based Equipment

Load Based Equipment may implement an LBT based spectrum sharing mechanism based on the Clear Channel Assessment (CCA) mode using energy detect as described in IEEE 802.11™ [i.3], clause 10 clause 11, clause 15, clause 16, clause 18 and clause 19, or in IEEE 802.15.4™ [i.4], clause 5, clause 6 and clause 10 providing the equipment complies with the conformance requirements referred to in clause 4.3.2.6.3.4. Load Based Equipment not using any of the mechanisms referenced above shall comply with the following minimum set of requirements:

- 1) Before a transmission or a burst of transmissions, the equipment shall perform a Clear Channel Assessment (CCA) check using energy detect. The equipment shall observe the operating channel for the duration of the CCA observation time which shall be not less than 18 µs. The channel shall be considered occupied if the energy level in the channel exceeds the threshold given in step 5 below. If the equipment finds the channel to be clear, it may transmit immediately.
- 2) If the equipment finds the channel occupied, it shall not transmit on this channel (see also the next paragraph). The equipment shall perform an Extended CCA check in which the channel is observed for a random duration in the range between 18 µs and at least 160 µs. If the extended CCA check has determined the channel to be no longer occupied, the equipment may resume transmissions on this channel. If the Extended CCA time has determined the channel still to be occupied, it shall perform new Extended CCA checks until the channel is no longer occupied.

NOTE: The Idle Period in between transmissions is considered to be the CCA or the Extended CCA check as there are no transmissions during this period.

The equipment is allowed to switch to a non-adaptive mode and to continue transmissions on this channel providing it complies with the requirements applicable to non-adaptive equipment. Alternatively, the equipment is also allowed to continue Short Control Signalling Transmissions on this channel providing it complies with the requirements given in clause 4.3.2.6.4.

Limit

Limit

- 3) The total time that an equipment makes use of a RF channel is defined as the Channel Occupancy Time. This Channel Occupancy Time shall be less than 13 ms, after which the device shall perform a new CCA as described in step 1 above.
- 4) The equipment, upon correct reception of a transmission which was intended for this equipment can skip CCA and immediately (see also next paragraph) proceed with the transmission of management and control frames. A consecutive sequence of transmissions by the equipment without a new CCA shall not exceed the maximum channel occupancy time as defined in step 3 above.
For the purpose of multi-cast, the ACK transmissions (associated with the same data packet) of the individual devices are allowed to take place in a sequence.
- 5) The energy detection threshold for the CCA shall be proportional to the transmit power of the transmitter: for a 20 dBm e.i.r.p. transmitter the CCA threshold level (TL) shall be equal to or less than -70 dBm/MHz at the input to the receiver assuming a 0 dBi (receive) antenna assembly. This threshold level (TL) may be corrected for the (receive) antenna assembly gain (G); however, beamforming gain (Y) shall not be taken into account. For power levels less than 20 dBm e.i.r.p., the CCA threshold level may be relaxed to:

$$TL = -70 \text{ dBm/MHz} + 10 \times \log_{10} (100 \text{ mW}/P_{\text{out}}) \text{ (} P_{\text{out}} \text{ in mW e.i.r.p.)}$$
- 6) The equipment shall comply with the requirements defined in step 1 to step 4 of the present clause in the presence of an unwanted CW signal as defined in table 11.

Table 11: Unwanted Signal parameters

Wanted signal mean power from companion device	Unwanted signal frequency (MHz)	Unwanted signal power (dBm)
sufficient to maintain the link (see note 2)	2 395 or 2 488,5 (see note 1)	-35 (see note 3)
NOTE 1: The highest frequency shall be used for testing operating channels within the range 2 400 MHz to 2 442 MHz, while the lowest frequency shall be used for testing operating channels within the range 2 442 MHz to 2 483,5 MHz. See clause 5.4.6.1. NOTE 2: A typical conducted value which can be used in most cases is -50 dBm/MHz. NOTE 3: The level specified is the level at the UUT receiver input assuming a 0 dBi antenna assembly gain. In case of conducted measurements, this level has to be corrected for the (in-band) antenna assembly gain (G). In case of radiated measurements, this level is equivalent to a power flux density (PFD) in front of the UUT antenna.		

Short Control Signalling Transmissions

If implemented, Short Control Signalling Transmissions of adaptive non-FHSS equipment shall have a maximum TxOn / (TxOn + TxOff) ratio of 10 % within any observation period of 50 ms.

NOTE: Duty Cycle is defined in clause 4.3.2.4.2.

7.2 TEST PROCEDURES

Refer to ETSI EN 300 328, chapter 5.4.6.2.1.

7.3 TEST SETUP LAYOUT

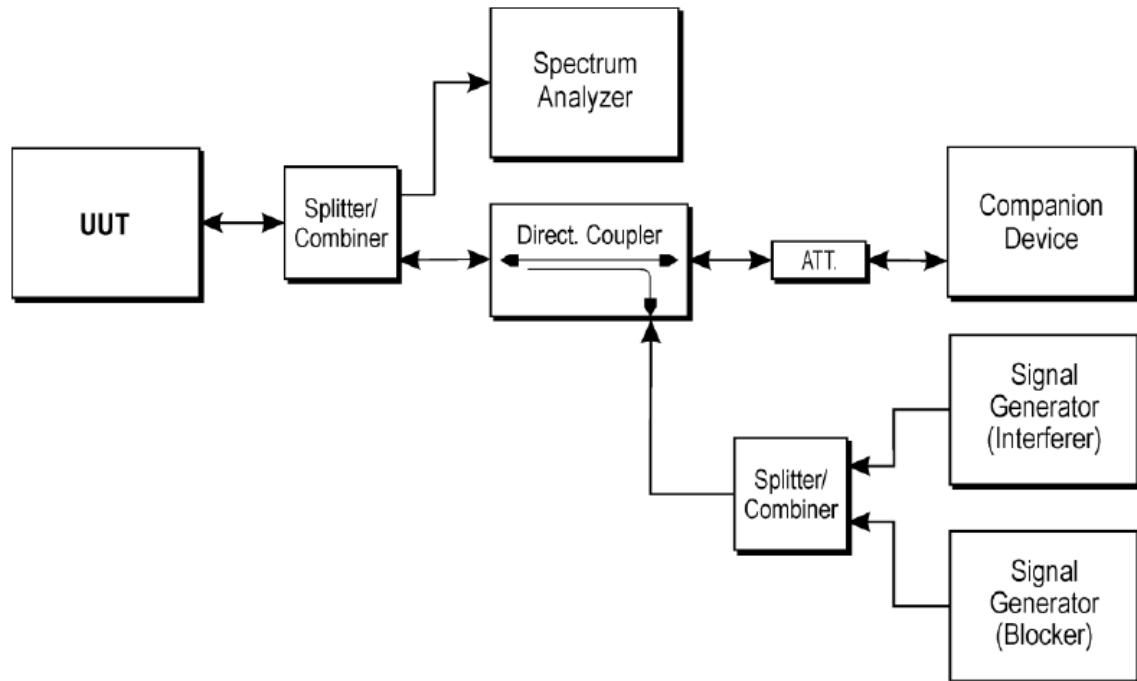

7.4 TEST DEVIATION

There is no deviation with the original standard.

7.5 EUT OPERATION DURING TEST

The measurements shall be performed during normal operation.

7.6 TEST RESULTS

Please refer to the Appendix E.

8. OCCUPIED CHANNEL BANDWIDTH

8.1 APPLIED PROCEDURES / LIMIT

Clause	4.3.2.7						
Test Item	Occupied Channel Bandwidth						
Limit	<p>The Occupied Channel Bandwidth shall be within the band given in table 1.</p> <p style="text-align: center;">Table 1: Service frequency bands</p> <table border="1" style="margin-left: auto; margin-right: auto;"> <thead> <tr> <th></th> <th>Service frequency bands</th> </tr> </thead> <tbody> <tr> <td>Transmit</td> <td>2 400 MHz to 2 483,5 MHz</td> </tr> <tr> <td>Receive</td> <td>2 400 MHz to 2 483,5 MHz</td> </tr> </tbody> </table> <p>In addition, for non-adaptive non-FHSS equipment with e.i.r.p. greater than 10 dBm, the Occupied Channel Bandwidth shall be equal to or less than 20 MHz.</p>		Service frequency bands	Transmit	2 400 MHz to 2 483,5 MHz	Receive	2 400 MHz to 2 483,5 MHz
	Service frequency bands						
Transmit	2 400 MHz to 2 483,5 MHz						
Receive	2 400 MHz to 2 483,5 MHz						

8.2 TEST PROCEDURES

Refer to ETSI EN 300 328, chapter 5.4.7.2.1.

8.3 TEST SETUP LAYOUT

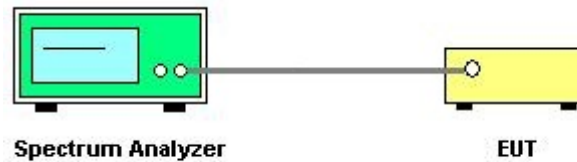

8.4 TEST DEVIATION

There is no deviation with the original standard.

8.5 EUT OPERATION DURING TEST

The measurements shall be performed during continuously transmitting.

8.6 TEST RESULTS

Please refer to the Appendix F.

9. TRANSMITTER UNWANTED EMISSIONS IN THE OUT-OF-BAND DOMAIN

9.1 APPLIED PROCEDURES / LIMIT

Clause	4.3.2.8
Test Item	Transmitter unwanted emissions in the out-of-band domain
Limit	<p>The transmitter unwanted emissions in the out-of-band domain shall not exceed the values provided by the mask in figure 3.</p> <p> A: -10 dBm/MHz e.i.r.p. B: -20 dBm/MHz e.i.r.p. C: Spurious Domain limits </p> <p>BW = Occupied Channel Bandwidth in MHz or 1 MHz whichever is greater</p>

Figure 3: Transmit mask

9.2 TEST PROCEDURES

Refer to ETSI EN 300 328, chapter 5.4.8.2.1.

9.3 TEST SETUP LAYOUT



9.4 TEST DEVIATION

There is no deviation with the original standard.

9.5 EUT OPERATION DURING TEST

The measurements shall be performed during continuously transmitting.

9.6 TEST RESULTS

Please refer to the Appendix G.

10. TRANSMITTER UNWANTED EMISSIONS IN THE SPURIOUS DOMAIN

10.1 APPLIED PROCEDURES / LIMIT

Clause	4.3.2.9																																	
Test Item	Transmitter unwanted emissions in the spurious domain																																	
Limit	<p>The transmitter unwanted emissions in the spurious domain shall not exceed the values given in table 12. In case of equipment with antenna connectors, these limits apply to emissions at the antenna port (conducted). For emissions radiated by the cabinet or emissions radiated by integral antenna equipment (without antenna connectors), these limits are e.r.p. for emissions up to 1 GHz and as e.i.r.p. for emissions above 1 GHz.</p> <p style="text-align: center;">Table 12: Transmitter limits for spurious emissions</p> <table border="1" style="margin-left: auto; margin-right: auto;"> <thead> <tr> <th>Frequency range</th> <th>Maximum power</th> <th>Bandwidth</th> </tr> </thead> <tbody> <tr> <td>30 MHz to 47 MHz</td> <td>-36 dBm</td> <td>100 kHz</td> </tr> <tr> <td>47 MHz to 74 MHz</td> <td>-54 dBm</td> <td>100 kHz</td> </tr> <tr> <td>74 MHz to 87,5 MHz</td> <td>-36 dBm</td> <td>100 kHz</td> </tr> <tr> <td>87,5 MHz to 118 MHz</td> <td>-54 dBm</td> <td>100 kHz</td> </tr> <tr> <td>118 MHz to 174 MHz</td> <td>-36 dBm</td> <td>100 kHz</td> </tr> <tr> <td>174 MHz to 230 MHz</td> <td>-54 dBm</td> <td>100 kHz</td> </tr> <tr> <td>230 MHz to 470 MHz</td> <td>-36 dBm</td> <td>100 kHz</td> </tr> <tr> <td>470 MHz to 694 MHz</td> <td>-54 dBm</td> <td>100 kHz</td> </tr> <tr> <td>694 MHz to 1 GHz</td> <td>-36 dBm</td> <td>100 kHz</td> </tr> <tr> <td>1 GHz to 12,75 GHz</td> <td>-30 dBm</td> <td>1 MHz</td> </tr> </tbody> </table>	Frequency range	Maximum power	Bandwidth	30 MHz to 47 MHz	-36 dBm	100 kHz	47 MHz to 74 MHz	-54 dBm	100 kHz	74 MHz to 87,5 MHz	-36 dBm	100 kHz	87,5 MHz to 118 MHz	-54 dBm	100 kHz	118 MHz to 174 MHz	-36 dBm	100 kHz	174 MHz to 230 MHz	-54 dBm	100 kHz	230 MHz to 470 MHz	-36 dBm	100 kHz	470 MHz to 694 MHz	-54 dBm	100 kHz	694 MHz to 1 GHz	-36 dBm	100 kHz	1 GHz to 12,75 GHz	-30 dBm	1 MHz
Frequency range	Maximum power	Bandwidth																																
30 MHz to 47 MHz	-36 dBm	100 kHz																																
47 MHz to 74 MHz	-54 dBm	100 kHz																																
74 MHz to 87,5 MHz	-36 dBm	100 kHz																																
87,5 MHz to 118 MHz	-54 dBm	100 kHz																																
118 MHz to 174 MHz	-36 dBm	100 kHz																																
174 MHz to 230 MHz	-54 dBm	100 kHz																																
230 MHz to 470 MHz	-36 dBm	100 kHz																																
470 MHz to 694 MHz	-54 dBm	100 kHz																																
694 MHz to 1 GHz	-36 dBm	100 kHz																																
1 GHz to 12,75 GHz	-30 dBm	1 MHz																																

10.2 TEST PROCEDURES

Refer to ETSI EN 300 328, chapter 5.4.9.2.2.

10.3 TEST SETUP LAYOUT

Emission Radiated Measurement Test Set-Up Frequency Below 1 GHz

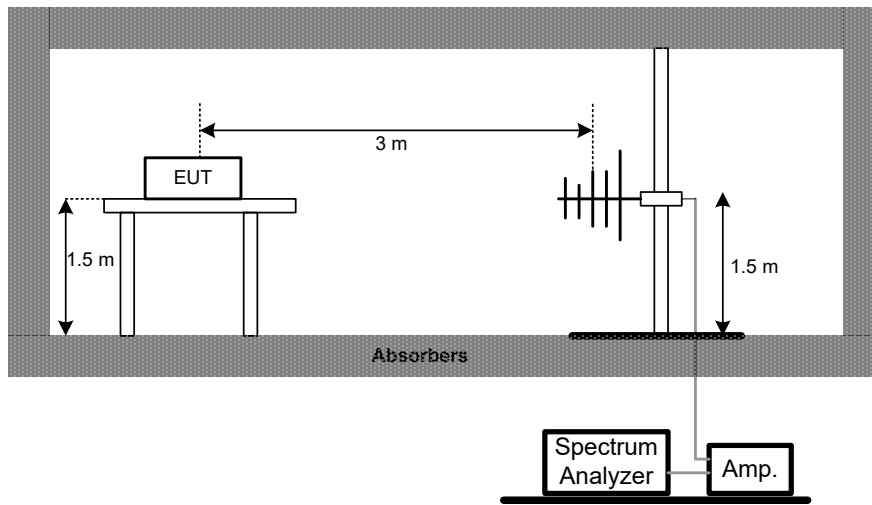

Emission Radiated Measurement Test Set-Up Frequency Above 1 GHz

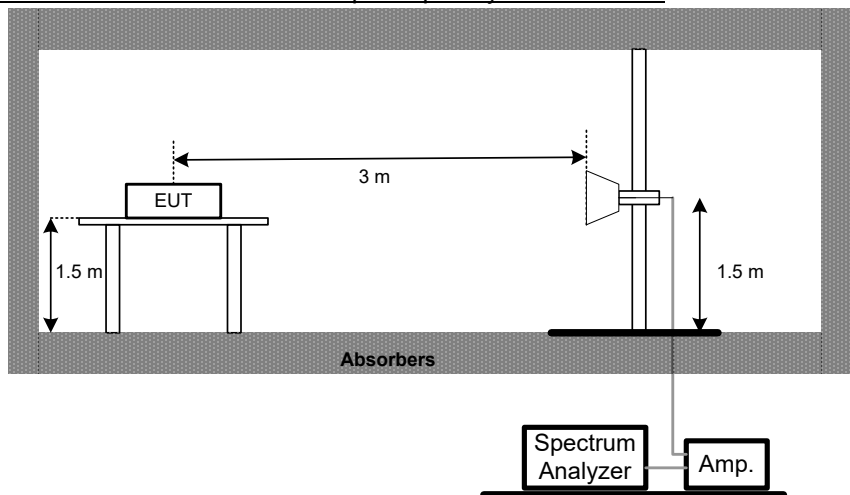

10.4 TEST DEVIATION

There is no deviation with the original standard.

10.5 EUT OPERATION DURING TEST

The measurements shall be performed during continuously transmitting.

10.6 TEST RESULTS

Please refer to the Appendix H.

11. RECEIVER SPURIOUS EMISSIONS

11.1 APPLIED PROCEDURES / LIMIT

Clause	4.3.2.10		
Test Item	Receiver spurious emissions		
Limit	The spurious emissions of the receiver shall not exceed the values given in table 13. In case of non-FHSS equipment with antenna connectors, these limits apply to emissions at the antenna port (conducted). For emissions radiated by the cabinet or for emissions radiated by integral antenna equipment (without antenna connectors), these limits are e.r.p. for emissions up to 1 GHz and e.i.r.p. for emissions above 1 GHz.		
	Table 13: Spurious emission limits for receivers		
	Frequency range	Maximum power	Bandwidth
30 MHz to 1 GHz	-57 dBm	100 kHz	
1 GHz to 12,75 GHz	-47 dBm	1 MHz	

11.2 TEST PROCEDURES

Refer to ETSI EN 300 328, chapter 5.4.10.2.2.

11.3 TEST SETUP LAYOUT

Refer to clause 10.3.

11.4 TEST DEVIATION

There is no deviation with the original standard.

11.5 EUT OPERATION DURING TEST

The measurements shall be performed during continuously receiving.

11.6 TEST RESULTS

Please refer to the Appendix I.

12. RECEIVER BLOCKING

12.1 APPLIED PROCEDURES / LIMIT

Clause	4.3.2.11										
Test Item	Receiver Blocking										
Limit	<p>While maintaining the minimum performance criteria as defined in clause 4.3.2.11.3, the blocking levels at specified frequency offsets shall be equal to or greater than the limits defined for the applicable receiver category provided in table 14, table 15 or table 16.</p> <p>Receiver Category 1 Table 14 contains the Receiver Blocking parameters for Receiver Category 1 equipment.</p> <p style="text-align: center;">Table 14: Receiver Blocking parameters for Receiver Category 1 equipment</p> <table border="1"> <thead> <tr> <th>Wanted signal mean power from companion device (dBm) (see notes 1 and 4)</th> <th>Blocking signal frequency (MHz)</th> <th>Blocking signal power (dBm) (see note 4)</th> <th>Type of blocking signal</th> </tr> </thead> <tbody> <tr> <td>$(-133 \text{ dBm} + 10 \times \log_{10}(\text{OCBW}))$ or -68 dBm whichever is less (see note 2)</td> <td>2 380 2 504</td> <td rowspan="2" style="text-align: center;">-34</td> <td rowspan="2" style="text-align: center;">CW</td> </tr> <tr> <td>$(-139 \text{ dBm} + 10 \times \log_{10}(\text{OCBW}))$ or -74 dBm whichever is less (see note 3)</td> <td>2 300 2 330 2 360 2 524 2 584 2 674</td> </tr> </tbody> </table> <p>NOTE 1: OCBW is in Hz. NOTE 2: In case of radiated measurements using a companion device and the level of the wanted signal from the companion device cannot be determined, a relative test may be performed using a wanted signal up to $P_{\min} + 26 \text{ dB}$ where P_{\min} is the minimum level of wanted signal required to meet the minimum performance criteria as defined in clause 4.3.1.12.3 in the absence of any blocking signal. NOTE 3: In case of radiated measurements using a companion device and the level of the wanted signal from the companion device cannot be determined, a relative test may be performed using a wanted signal up to $P_{\min} + 20 \text{ dB}$ where P_{\min} is the minimum level of wanted signal required to meet the minimum performance criteria as defined in clause 4.3.1.12.3 in the absence of any blocking signal. NOTE 4: The level specified is the level at the UUT receiver input assuming a 0 dBi antenna assembly gain. In case of conducted measurements, this level has to be corrected for the (in-band) antenna assembly gain (G). In case of radiated measurements, this level is equivalent to a power flux density (PFD) in front of the UUT antenna with the UUT being configured/positioned as recorded in clause 5.4.3.2.2.</p>	Wanted signal mean power from companion device (dBm) (see notes 1 and 4)	Blocking signal frequency (MHz)	Blocking signal power (dBm) (see note 4)	Type of blocking signal	$(-133 \text{ dBm} + 10 \times \log_{10}(\text{OCBW}))$ or -68 dBm whichever is less (see note 2)	2 380 2 504	-34	CW	$(-139 \text{ dBm} + 10 \times \log_{10}(\text{OCBW}))$ or -74 dBm whichever is less (see note 3)	2 300 2 330 2 360 2 524 2 584 2 674
	Wanted signal mean power from companion device (dBm) (see notes 1 and 4)	Blocking signal frequency (MHz)	Blocking signal power (dBm) (see note 4)	Type of blocking signal							
$(-133 \text{ dBm} + 10 \times \log_{10}(\text{OCBW}))$ or -68 dBm whichever is less (see note 2)	2 380 2 504	-34	CW								
$(-139 \text{ dBm} + 10 \times \log_{10}(\text{OCBW}))$ or -74 dBm whichever is less (see note 3)	2 300 2 330 2 360 2 524 2 584 2 674										
	<p>Receiver Category 2 Table 15 contains the Receiver Blocking parameters for Receiver Category 2 equipment.</p> <p style="text-align: center;">Table 15: Receiver Blocking parameters receiver Category 2 equipment</p> <table border="1"> <thead> <tr> <th>Wanted signal mean power from companion device (dBm) (see notes 1 and 3)</th> <th>Blocking signal frequency (MHz)</th> <th>Blocking signal power (dBm) (see note 3)</th> <th>Type of blocking signal</th> </tr> </thead> <tbody> <tr> <td>$(-139 \text{ dBm} + 10 \times \log_{10}(\text{OCBW}) + 10 \text{ dB})$ or $(-74 \text{ dBm} + 10 \text{ dB})$ whichever is less (see note 2)</td> <td>2 380 2 504 2 300 2 584</td> <td style="text-align: center;">-34</td> <td style="text-align: center;">CW</td> </tr> </tbody> </table> <p>NOTE 1: OCBW is in Hz. NOTE 2: In case of radiated measurements using a companion device and the level of the wanted signal from the companion device cannot be determined, a relative test may be performed using a wanted signal up to $P_{\min} + 26 \text{ dB}$ where P_{\min} is the minimum level of wanted signal required to meet the minimum performance criteria as defined in clause 4.3.1.12.3 in the absence of any blocking signal. NOTE 3: The level specified is the level at the UUT receiver input assuming a 0 dBi antenna assembly gain. In case of conducted measurements, this level has to be corrected for the (in-band) antenna assembly gain (G). In case of radiated measurements, this level is equivalent to a power flux density (PFD) in front of the UUT antenna with the UUT being configured/positioned as recorded in clause 5.4.3.2.2.</p>	Wanted signal mean power from companion device (dBm) (see notes 1 and 3)	Blocking signal frequency (MHz)	Blocking signal power (dBm) (see note 3)	Type of blocking signal	$(-139 \text{ dBm} + 10 \times \log_{10}(\text{OCBW}) + 10 \text{ dB})$ or $(-74 \text{ dBm} + 10 \text{ dB})$ whichever is less (see note 2)	2 380 2 504 2 300 2 584	-34	CW		
Wanted signal mean power from companion device (dBm) (see notes 1 and 3)	Blocking signal frequency (MHz)	Blocking signal power (dBm) (see note 3)	Type of blocking signal								
$(-139 \text{ dBm} + 10 \times \log_{10}(\text{OCBW}) + 10 \text{ dB})$ or $(-74 \text{ dBm} + 10 \text{ dB})$ whichever is less (see note 2)	2 380 2 504 2 300 2 584	-34	CW								

Limit	Receiver Category 3 Table 16 contains the Receiver Blocking parameters for Receiver Category 3 equipment. Table 16: Receiver Blocking parameters receiver Category 3 equipment			
	Wanted signal mean power from companion device (dBm) (see notes 1 and 3)	Blocking signal frequency (MHz)	Blocking signal power (dBm) (see note 3)	Type of blocking signal
	(-139 dBm + 10 × log ₁₀ (OCBW) + 20 dB) or (-74 dBm + 20 dB) whichever is less (see note 2)	2 380 2 504 2 300 2 584	-34	CW
	NOTE 1: OCBW is in Hz. NOTE 2: In case of radiated measurements using a companion device and the level of the wanted signal from the companion device cannot be determined, a relative test may be performed using a wanted signal up to P _{min} + 30 dB where P _{min} is the minimum level of wanted signal required to meet the minimum performance criteria as defined in clause 4.3.1.12.3 in the absence of any blocking signal. NOTE 3: The level specified is the level at the UUT receiver input assuming a 0 dBi antenna assembly gain. In case of conducted measurements, this level has to be corrected for the (in-band) antenna assembly gain (G). In case of radiated measurements, this level is equivalent to a power flux density (PFD) in front of the UUT antenna with the UUT being configured/positioned as recorded in clause 5.4.3.2.2.			

12.2 TEST PROCEDURES

Refer to ETSI EN 300 328, chapter 5.4.11.2.1.

12.3 TEST SETUP LAYOUT

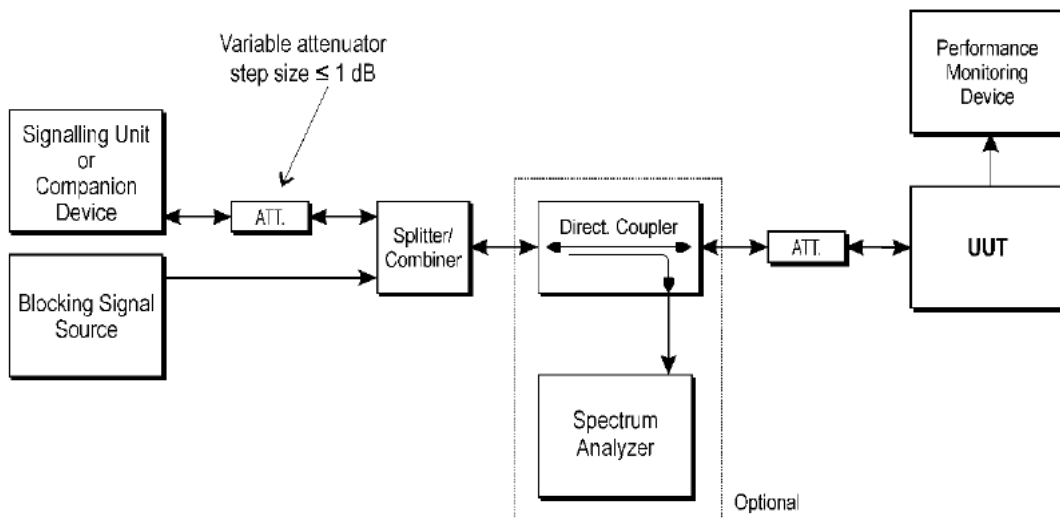

12.4 TEST DEVIATION

There is no deviation with the original standard.

12.5 EUT OPERATION DURING TEST

The measurements shall be performed during normal receiving.

12.6 TEST RESULTS

Please refer to the Appendix J.

13. MEASUREMENT INSTRUMENTS LIST

RF Output Power					
Item	Kind of Equipment	Manufacturer	Type No.	Serial No.	Calibrated until
1	Table top type high and low temperature test chamber	CEPREI	CEEC-M64T-40	15-008	Dec. 22, 2024
2	Power Sensor	Agilent	U2021XA	MY53320006	May 31, 2025
3	Power Sensor	Agilent	U2021XA	MY53340001	May 31, 2025
4	Cable	Woke	20210802 001	RWP50-402-S MSM-1M	N/A
5	Cable	RegalWay	S02-181212-308	RWP50-402-S MSM-1M	N/A
6	BTL TestSystem	BTL	TestSoftware	N/A	N/A
7	Attenuator	Talent Microwave	TA10A2-S-18	N/A	N/A
8	Attenuator	Talent Microwave	TA10A2-S-18	N/A	N/A

Power Spectral Density & Occupied Channel Bandwidth & Transmitter Unwanted Out Of Band Domain					
Item	Kind of Equipment	Manufacturer	Type No.	Serial No.	Calibrated until
1	EXA Spectrum Analyzer	Agilent	N9010A	MY54200164	Dec. 22, 2024
2	Cable	RegalWay	20210802 013	RWP50-402-S MSM-1M	N/A
3	Attenuator	Talent Microwave	TA10A0-S-26.5	N/A	N/A
4	Attenuator	Talent Microwave	TA10A0-S-26.5	N/A	N/A
5	DC Block	N/A	N/A	N/A	N/A
6	BTL TestSystem	BTL	TestSoftware	N/A	N/A

Adaptivity					
Item	Kind of Equipment	Manufacturer	Type No.	Serial No.	Calibrated until
1	EXA Spectrum Analyzer	Agilent	N9010A	MY54200164	Dec. 22, 2024
2	EXG Analog Signal Generator	Keysight	N5171B	MY53051228	Dec. 22, 2024
3	Shielding box	Jiachen	JC-PB2009	200917D0184A	N/A
4	EN 300 328 adaptivity	Keysight	AD191A	TW5451034	N/A
5	Power divider	N/A	PD-2SF-2080	N/A	Dec. 22, 2024
6	Attenuator	Mini-Circuits	VAT-30+	N/A	Dec. 22, 2024
7	Attenuator	N/A	N/A	N/A	N/A
8	DC Block	N/A	N/A	N/A	N/A
9	DC Block	N/A	N/A	N/A	N/A
10	DC Block	N/A	N/A	N/A	N/A
11	Gaming Router	Tplink	Archer GE800	N/A	N/A
12	Cable	RegalWay	20210802 013	RWP50-402-S MSM-1M	N/A
13	Cable	RegalWay	S02-1081212-050	RWP50-402-S MSM-1M	N/A
14	Cable	RegalWay	202108020 004	RWP50-402-S MSM-1M	N/A
15	Cable	RegalWay	20210802 021	RWP50-402-S MSM-1M	N/A
16	Cable	Woke	S02-181212-272	N/A	N/A
17	Cable	REBES	N/A	S02-1090322-0 18	N/A
18	MXG Vector Signal Generator	Agilent	N5182A	MY47420312	Jul. 07, 2025
19	BTL TestSystem	BTL	TestSoftware	N/A	N/A

Receiver Blocking					
Item	Kind of Equipment	Manufacturer	Type No.	Serial No.	Calibrated until
1	Cable	RegalWay	20210802 013	RWP50-402-SMS M-1M	N/A
2	Cable	RegalWay	S02-1081212-050	RWP50-402-SMS M-1M	N/A
3	DC Block	N/A	N/A	N/A	N/A
4	DC Block	N/A	N/A	N/A	N/A
5	MXG Vector Signal Generator	Agilent	N5182A	MY47420312	Jul. 07, 2025
6	Power Splitter	N/A	N/A	SZ201504789	Dec. 22, 2024
7	wideband radio communication tester	R&S	CMW500	152372	Dec. 22, 2024

Transmitter and Receiver Spurious Emission (Radiated Measurement)_Below 1GHz					
Item	Kind of Equipment	Manufacturer	Type No.	Serial No.	Calibrated until
1	Preamplifier	EMC INSTRUMENT	EMC001330	980986	May 31, 2025
2	EXA Signal Analyzer	Keysight	N9010A	MY56480488	Dec. 22, 2024
3	Antenna	Schwarzbeck	VULB9160	9160-3231	Apr. 14, 2025
4	Attenuator	SHX	TS2-6dB-6G-A	16101103	Apr. 14, 2025
5	Cable	Talent microwave	L6-NMNM-10M	N/A	N/A
6	Cable	RegalWay	LMR400-NMRANM-0.8M	N/A	N/A
7	Controller	Innco Systems GmbH	CO3000-4port	CO3000/1155/4 5430119/P	N/A
8	Measurement Software	Farad	EZ-EMC Ver.NB-03A1-01	N/A	N/A

Transmitter and Receiver Spurious Emission (Radiated Measurement)_Above 1GHz					
Item	Kind of Equipment	Manufacturer	Type No.	Serial No.	Calibrated until
1	EXA Signal Analyzer	Keysight	N9010A	MY56480488	Dec. 22, 2024
2	Cable	RegalWay	RWLP50-4.0A-SMR ANMRA-2M	N/A	N/A
3	DRG Horn Antenna	ETS	3117-PA	221576	Jul. 07, 2024
4	Preamplifier	ETS	3117-PA	221576	May 31, 2025
5	Cable	Talent microwave	A81-SMAMSMAM-12.5M	N/A	N/A
6	Measurement Software	Farad	EZ-EMC Ver.NB-03A1-01	N/A	N/A
7	Controller	Innco Systems GmbH	CO3000-4port	CO3000/1155/4 5430119/P	N/A
8	Filter	STI	STI15-9912	N/A	May 31, 2025
9	Attenuator	Talent Microwave	TA10A0-S-26.5	N/A	N/A

Remark: "N/A" denotes no model name, serial no. or calibration specified.

All calibration period of equipment list is one year.

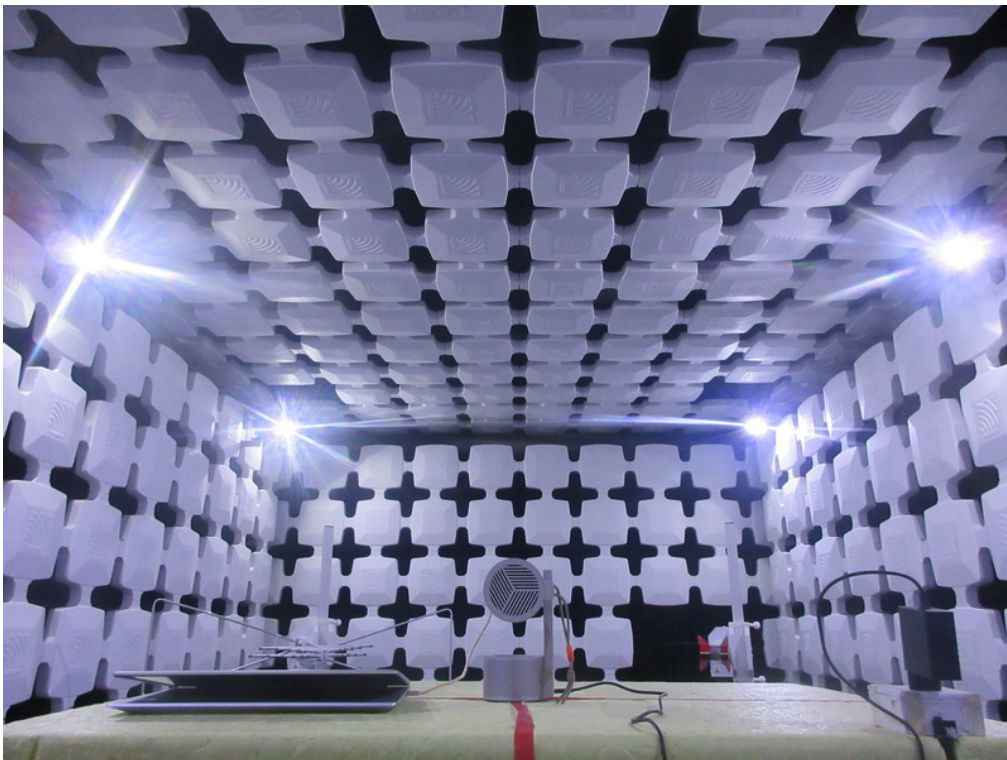
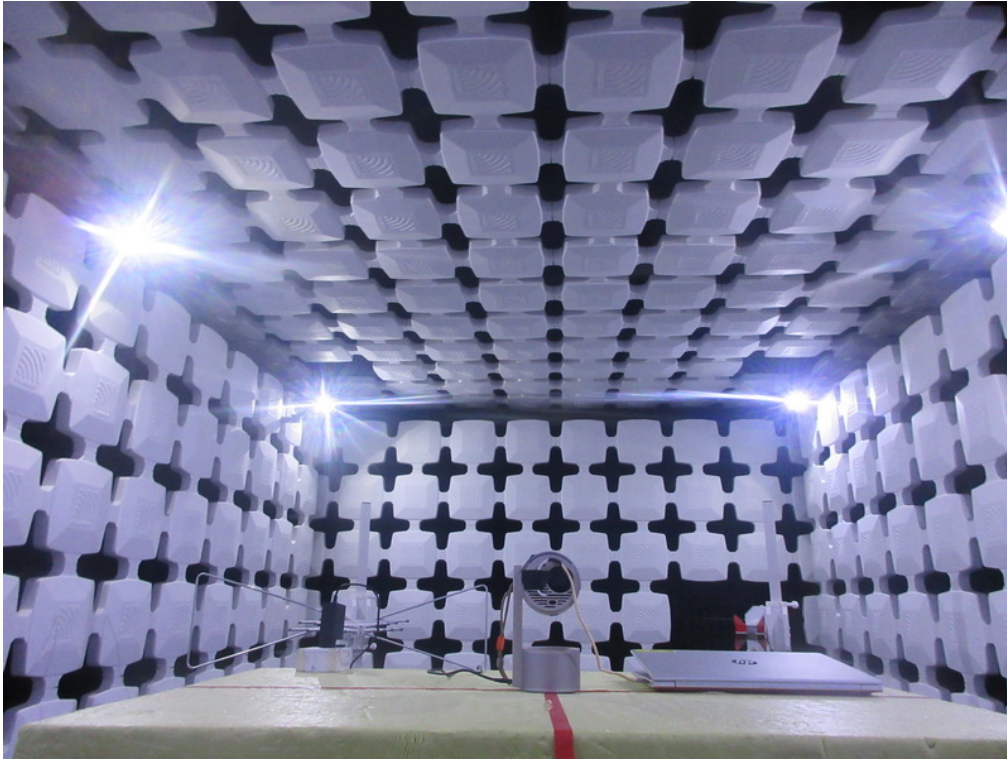
14. EUT TEST PHOTO**Radiated Emissions Test Photos**

APPENDIX A - RF OUTPUT POWER

Test Mode:	TX Mode_ IEEE 802.11b Mode
------------	----------------------------

Test Conditions		e.i.r.p. (dBm)			Number Of Bursts		
		CH01	CH07	CH11	CH01	CH07	CH11
T nom (°C)	22	17.53	17.48	17.34	13	13	13
T min (°C)	0	17.80	17.78	17.59	13	13	13
T max (°C)	40	17.25	17.18	17.11	13	13	13
Max. e.i.r.p.		17.80			Min Number		13
Limits		20dBm			≥ 10		
Result		Pass			Pass		

Test Mode:	TX Mode_ IEEE 802.11g Mode
------------	----------------------------

Test Conditions		e.i.r.p. (dBm)			Number Of Bursts		
		CH01	CH07	CH11	CH01	CH07	CH11
T nom (°C)	22	19.27	19.41	19.48	26	26	26
T min (°C)	0	19.54	19.66	19.80	26	26	26
T max (°C)	40	18.95	19.13	19.19	26	26	26
Max. e.i.r.p.		19.80			Min Number		26
Limits		20dBm			≥ 10		
Result		Pass			Pass		

Test Mode:	TX Mode_ IEEE 802.11n(HT20) Mode
------------	----------------------------------

Test Conditions		e.i.r.p. (dBm)			Number Of Bursts		
		CH01	CH07	CH11	CH01	CH07	CH11
T nom (°C)	22	19.17	19.14	19.26	29	29	29
T min (°C)	0	19.48	19.43	19.51	29	29	29
T max (°C)	40	18.94	18.82	19.01	29	29	29
Max. e.i.r.p.		19.51			Min Number		29
Limits		20dBm			≥ 10		
Result		Pass			Pass		

Test Mode:	TX Mode_ IEEE 802.11n(HT40) Mode
------------	----------------------------------

Test Conditions		e.i.r.p. (dBm)			Number Of Bursts		
		CH03	CH07	CH09	CH03	CH07	CH09
T nom (°C)	22	19.32	19.37	19.38	22	22	22
T min (°C)	0	19.65	19.60	19.66	22	22	22
T max (°C)	40	19.04	19.13	19.07	22	22	22
Max. e.i.r.p.		19.66			Min Number		22
Limits		20dBm			≥ 10		
Result		Pass			Pass		

Note:

- 1) e.i.r.p. = Conducted output power + G (Ant Gain)
- 2) Conducted output power = Measure result + Cable loss

APPENDIX B - POWER SPECTRAL DENSITY

Test Mode: TX Mode_ IEEE 802.11b Mode

Frequency (MHz)	Power Spectral Density (dBm/MHz)	Max. Limit (dBm/MHz)	Result
2412	9.98	10.00	Pass
2442	9.95	10.00	Pass
2462	9.91	10.00	Pass

IEEE 802.11b Mode 2412 MHz

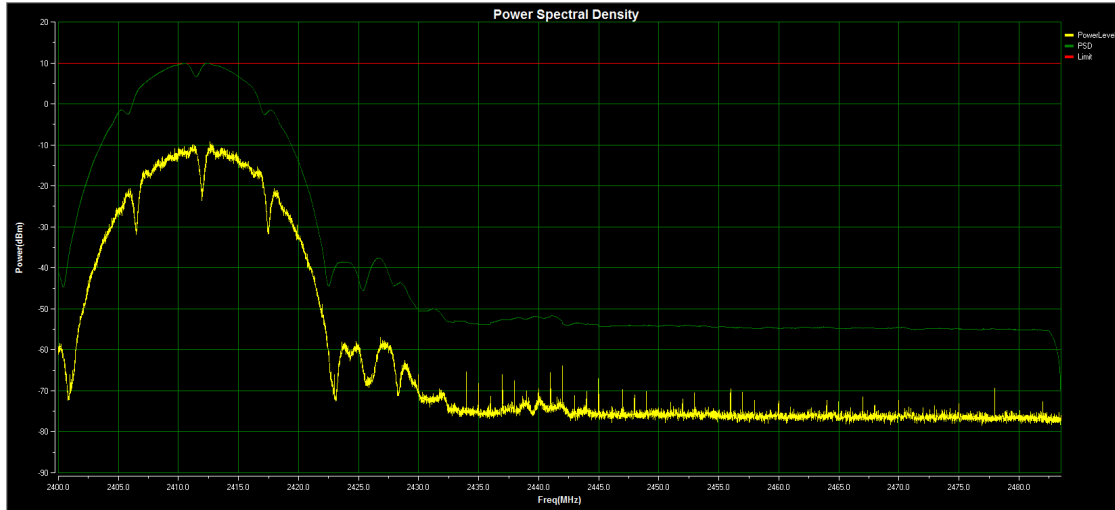

Power Density Result (dBm / MHz): 9.98 Limit: 10
 Test Result: Pass

IEEE 802.11b Mode 2442 MHz



Power Density Result(dBm / MHz):9.95 Limit:10
Test Result:Pass

IEEE 802.11b Mode 2462 MHz



Power Density Result(dBm / MHz):9.91 Limit:10
Test Result:Pass

Test Mode: TX Mode_ IEEE 802.11g Mode

Frequency (MHz)	Power Spectral Density (dBm/MHz)	Max. Limit (dBm/MHz)	Result
2412	8.77	10.00	Pass
2442	8.83	10.00	Pass
2462	8.83	10.00	Pass

IEEE 802.11g Mode 2412 MHz

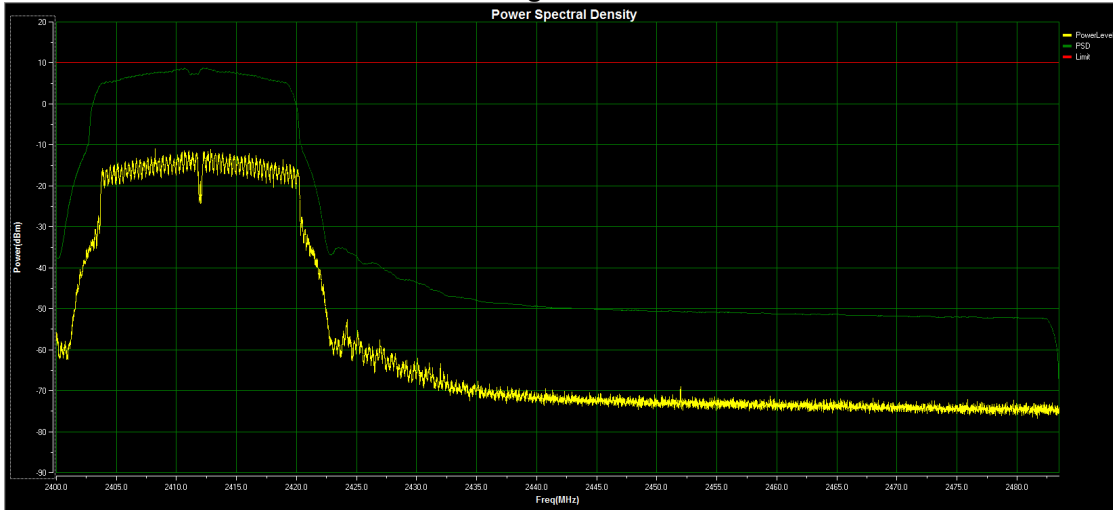

Power Density Result (dBm / MHz): 8.77 Limit: 10
 Test Result: Pass

IEEE 802.11g Mode 2442 MHz

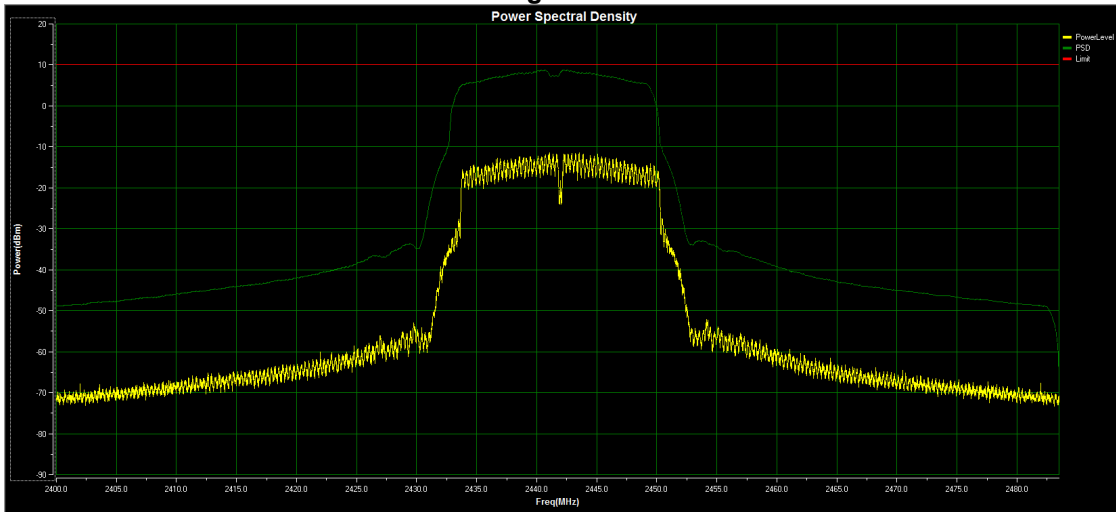

Power Density Result (dBm / MHz): 8.83 Limit: 10
Test Result: Pass

IEEE 802.11g Mode 2462 MHz



Power Density Result (dBm / MHz): 8.83 Limit: 10
Test Result: Pass

Test Mode: TX Mode_ IEEE 802.11n(HT20) Mode

Frequency (MHz)	Power Spectral Density (dBm/MHz)	Max. Limit (dBm/MHz)	Result
2412	8.44	10.00	Pass
2442	8.42	10.00	Pass
2462	8.41	10.00	Pass

IEEE 802.11n(HT20) Mode 2412 MHz

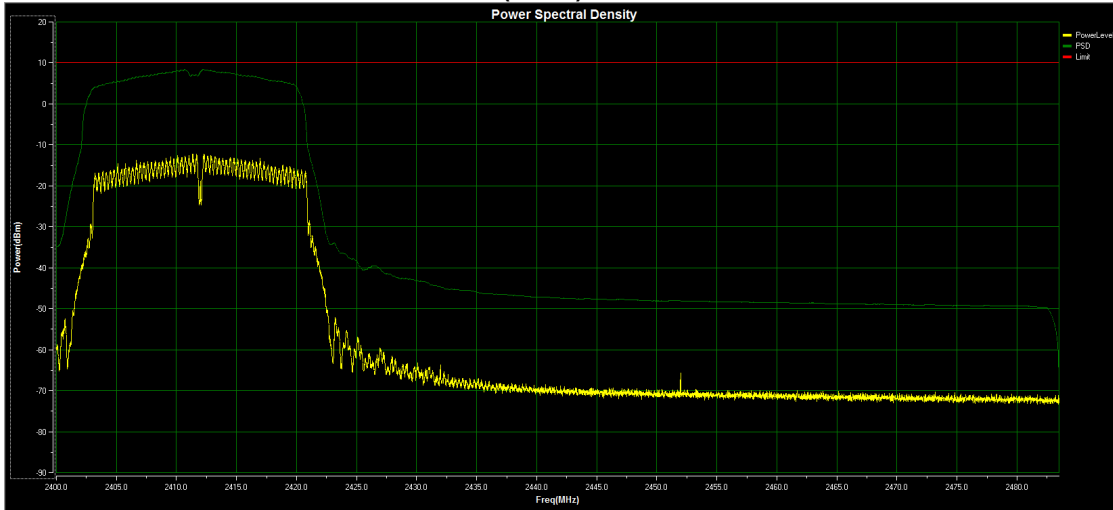

Power Density Result (dBm / MHz): 8.44 Limit: 10
 Test Result: Pass

IEEE 802.11n(HT20) Mode 2442 MHz

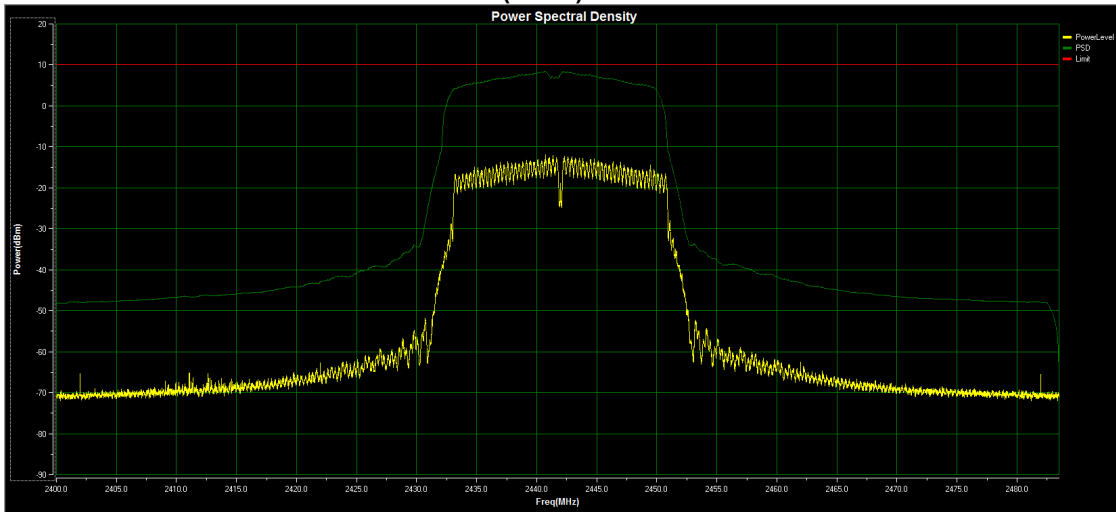

Power Density Result(dBm / MHz):8.42 Limit:10
Test Result:Pass

IEEE 802.11n(HT20) Mode 2462 MHz



Power Density Result(dBm / MHz):8.41 Limit:10
Test Result:Pass

Test Mode: TX Mode_ IEEE 802.11n(HT40) Mode

Frequency (MHz)	Power Spectral Density (dBm/MHz)	Max. Limit (dBm/MHz)	Result
2422	5.50	10.00	Pass
2442	5.77	10.00	Pass
2452	5.55	10.00	Pass

IEEE 802.11n(HT40) Mode 2422 MHz

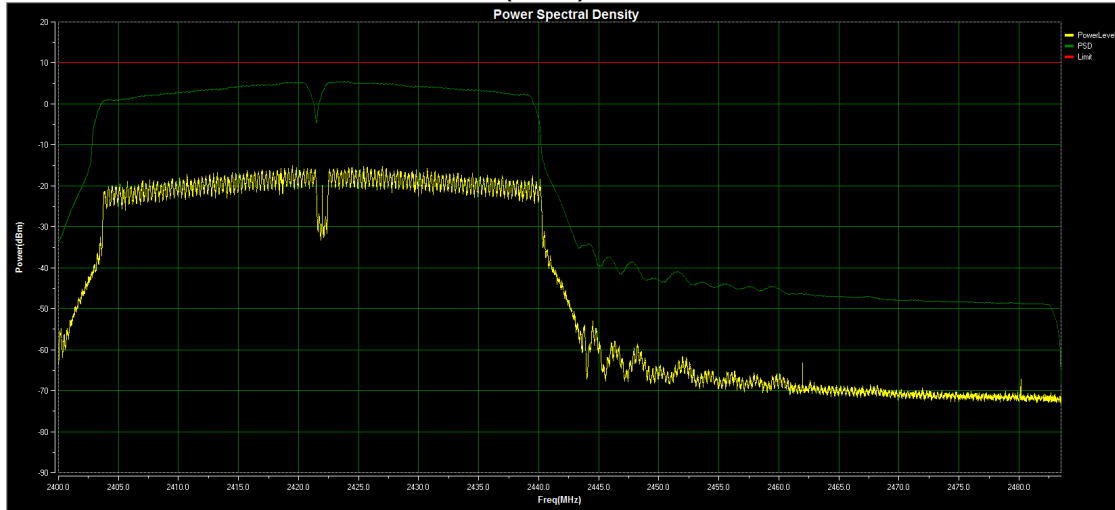

Power Density Result (dBm / MHz): 5.50 Limit: 10
 Test Result: Pass

IEEE 802.11n(HT40) Mode 2442 MHz

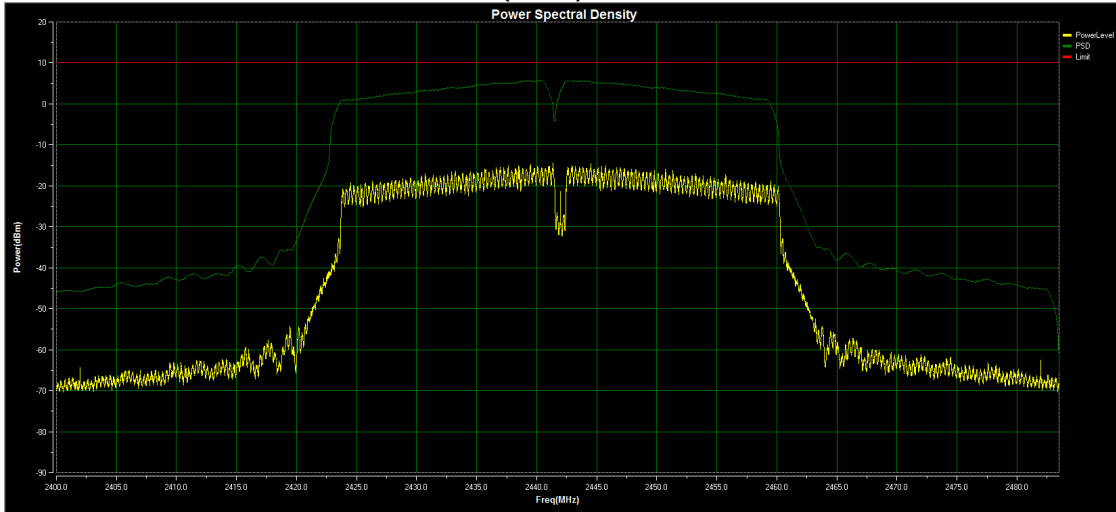

Power Density Result (dBm / MHz): 5.77 Limit: 10
Test Result: Pass

IEEE 802.11n(HT40) Mode 2452 MHz



Power Density Result (dBm / MHz): 5.55 Limit: 10
Test Result: Pass

APPENDIX C - DUTY CYCLE, TX-SEQUENCE, TX-GAP

Test Mode: N/A

Note: "N/A" denotes test is not applicable to this device.

APPENDIX D - MEDIUM UTILIZATION (MU) FACTOR

Test Mode: N/A

Note: "N/A" denotes test is not applicable to this device.

APPENDIX E - ADAPTIVITY

UUT Operational Mode	Frame Based Equipment	
	Load Based Equipment (CCA using 'energy detect')	✓
	Load Based Equipment (CCA not using any of the mechanisms referenced)	

Clause	Test Parameter	Remarks	Pass / Fail
4.3.2.6.3.2.2	Adaptive (Frame Based Equipment)	Not Applicable	N/A
4.3.2.6.3.2.3	Adaptive (Load Based Equipment)	Applicable	Pass
4.3.2.6.4	Short Control Signalling Transmissions	Applicable	Pass

Test Mode:	TX Mode_ IEEE 802.11b Mode
------------	----------------------------

Channel Occupancy Time and Clear Channel Assessment Measured Results		
Freq.(MHz)	Channel Occupancy Time (ms)	Clear Channel Assessment (us)
2412	2.68	155
2462	2.68	155
Limit	13	18~160
Note: Channel Occupancy Time and Clear Channel Assessment follow as IEEE Std. 802.11-2012 and IEEE 802.11n-2012 Specification without restriction.		

Adaptivity		
Adaptivity Detection Threshold Level	2412 MHz	-63.83 dBm/MHz
	2462 MHz	-63.64 dBm/MHz
Freq.(MHz)	Short Control Signalling Transmissions (ms)	
2412	1	
2462	2.75	
Limit	5	
Result	Pass	
Note: Threshold Level = -70 dBm/MHz + 10 x log ₁₀ (100 mW/P _{out}) + EUT Antenna Gain (P _{out} in mW e.i.r.p.) Short Control Signalling Transmissions = 50 (ms) * Duty cycle (%)		

IEEE 802.11b Mode 2412 MHz

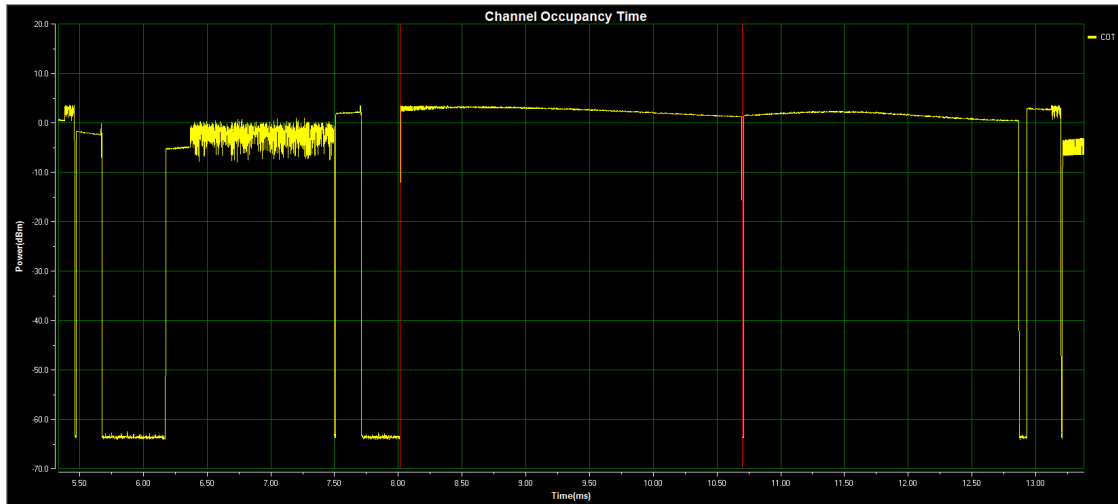

Max Channel Occupancy Time (ms): 2.68
Please make sure the COT less than 13ms, Or it will be failed

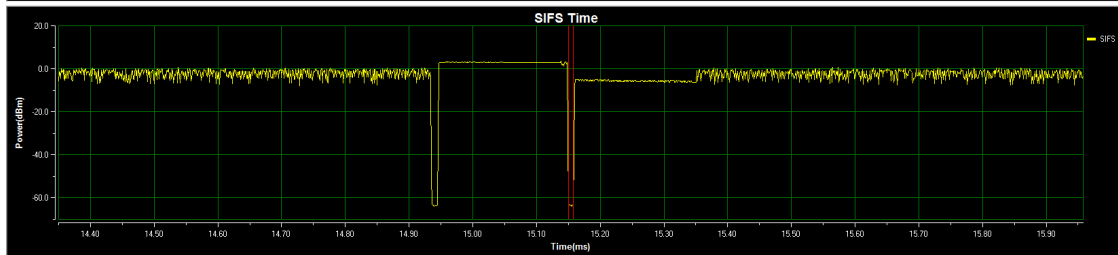
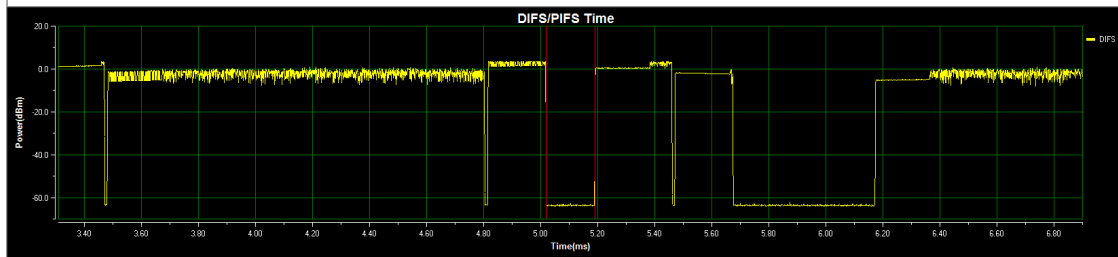

DIFS/PIFS (us): 171.00 SIFS (us): 8.00
Measured CCA (us): 155.00 Maximum CCA time should be between 18us ~ 160us

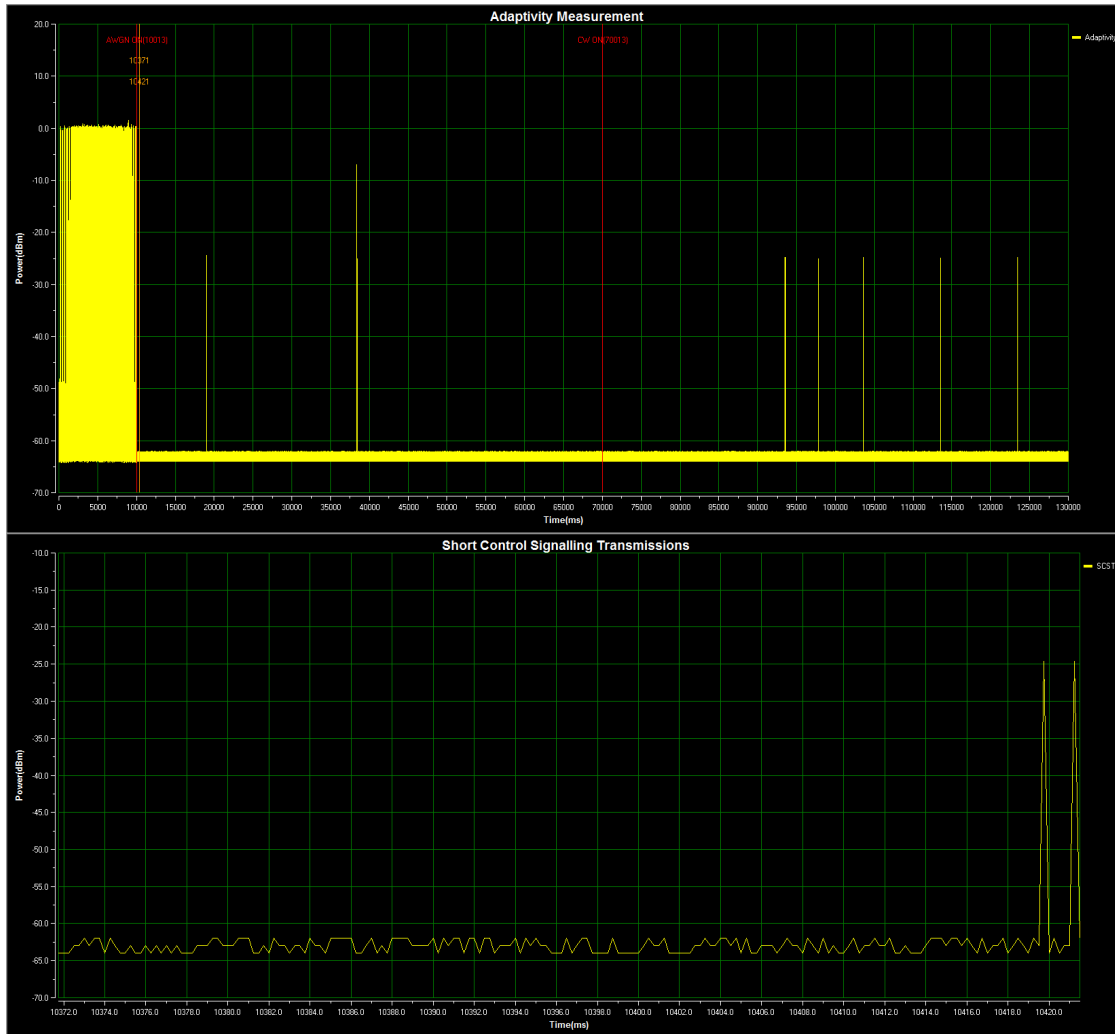

Duty Cycle (%):2.00 Short Control Signalling Transmissions Time (ms):1.00
Test Result:Pass

IEEE 802.11b Mode 2462 MHz

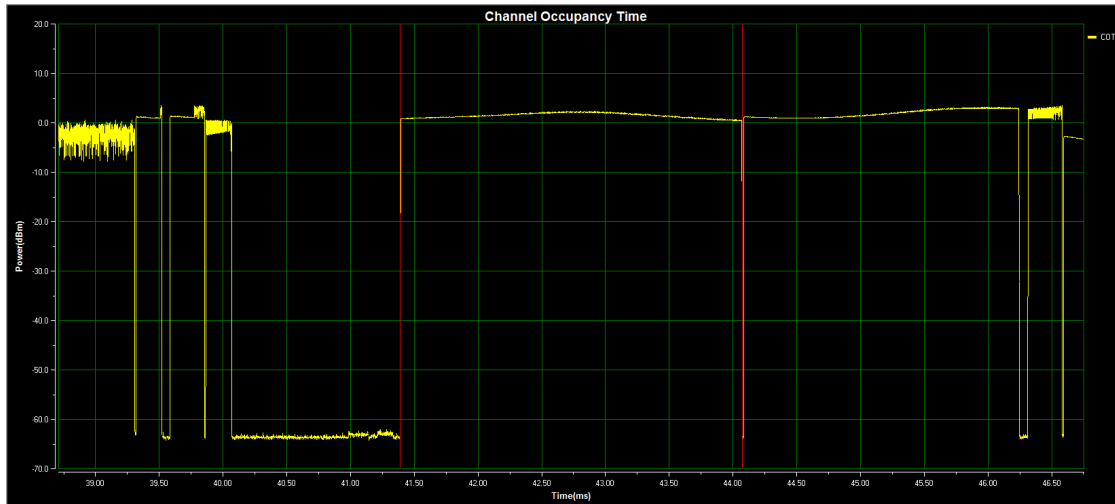

Max Channel Occupancy Time (ms): 2.68
Please make sure the COT less than 13ms, Or it will be failed

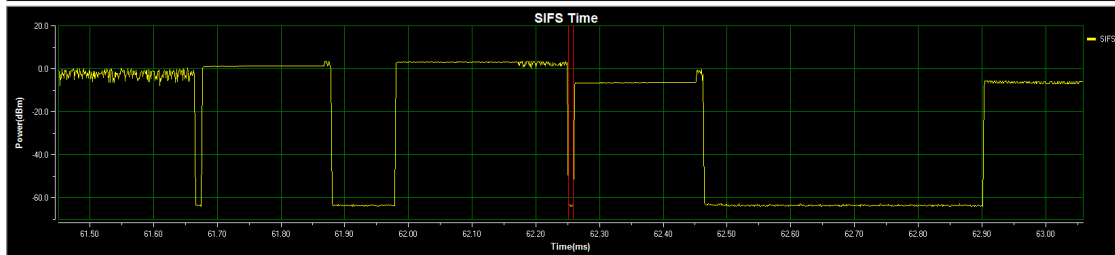
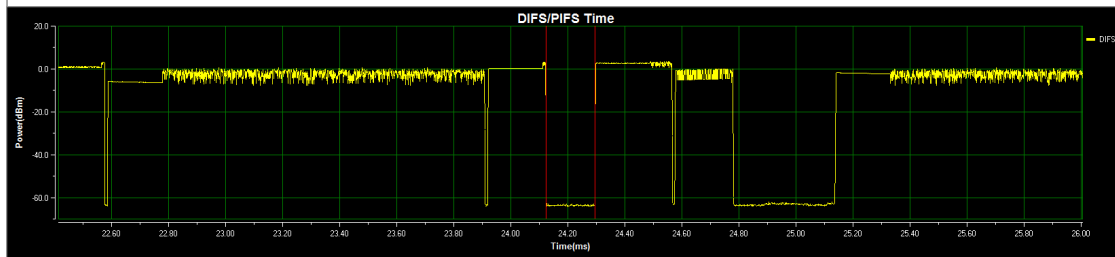

DIFS/PIFS(μs): 171.00 SIFS(μs): 8.00
Measured CCA(μs): 155.00 Maximum CCA time should be between 18μs ~ 160μs

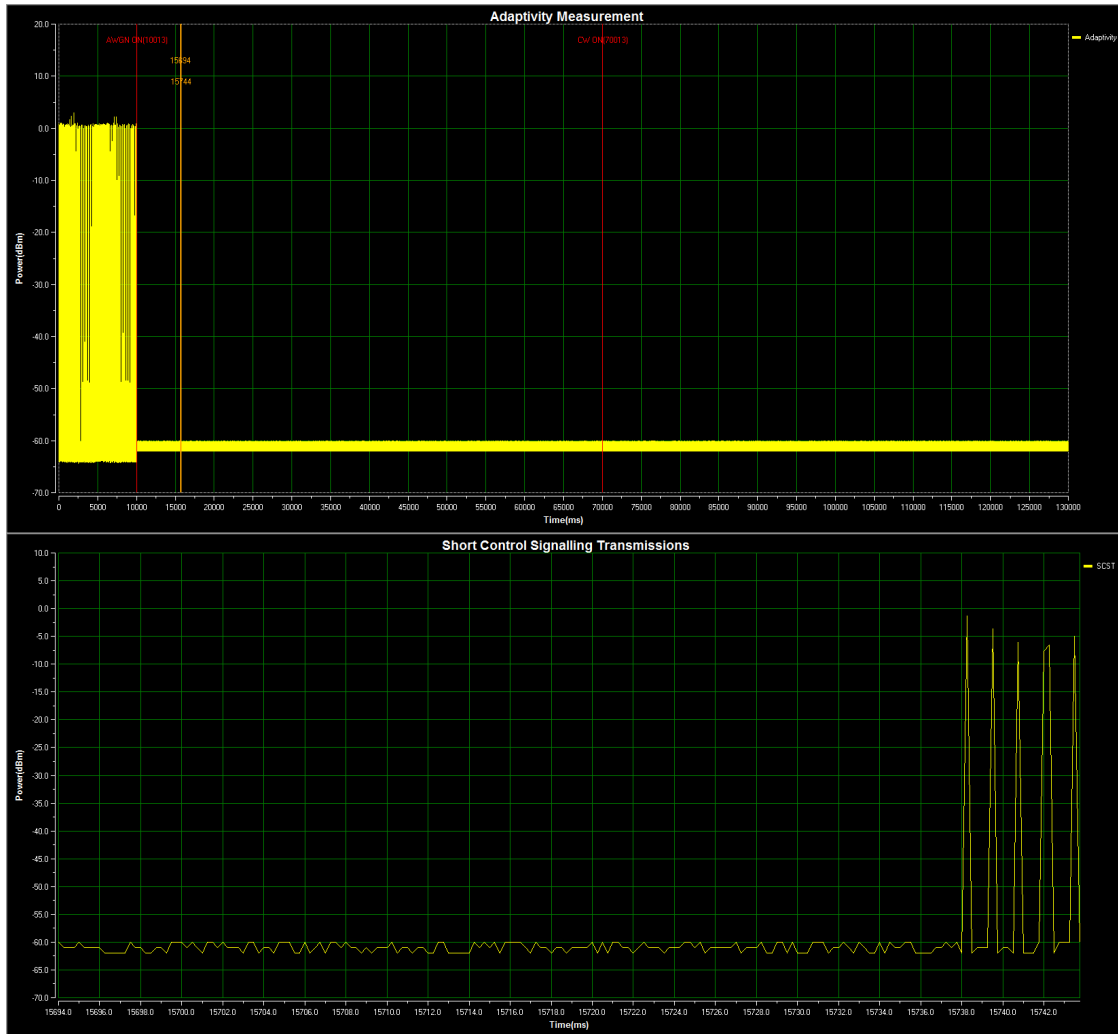

Duty Cycle (%):5.50 Short Control Signalling Transmissions Time (ms):2.75
 Test Result:Pass

Test Mode:	TX Mode_ IEEE 802.11g Mode
------------	----------------------------

Channel Occupancy Time and Clear Channel Assessment Measured Results

Freq.(MHz)	Channel Occupancy Time (ms)	Clear Channel Assessment (us)
2412	2.79	159
2462	2.79	155
Limit	13	18~160

Note: Channel Occupancy Time and Clear Channel Assessment follow as IEEE Std. 802.11-2012 and IEEE 802.11n-2012 Specification without restriction.

Adaptivity

Adaptivity Detection Threshold Level	2412 MHz	-65.57 dBm/MHz
	2462 MHz	-65.78 dBm/MHz
Freq.(MHz)	Short Control Signalling Transmissions (ms)	
2412	1	
2462	1	
Limit	5	
Result	Pass	

Note: Threshold Level = $-70 \text{ dBm/MHz} + 10 \times \log_{10} (100 \text{ mW}/P_{\text{out}}) + \text{EUT Antenna Gain}$
 (P_{out} in mW e.i.r.p.)
 Short Control Signalling Transmissions = 50 (ms) * Duty cycle (%)

IEEE 802.11g Mode 2412 MHz

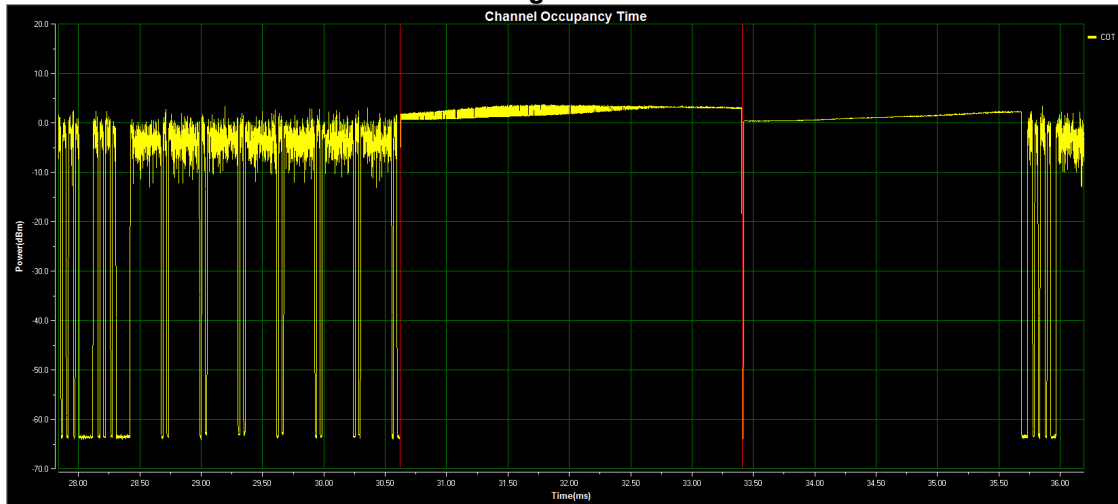

Max Channel Occupancy Time (ms): 2.79
Please make sure the COT less than 13ms, Or it will be failed

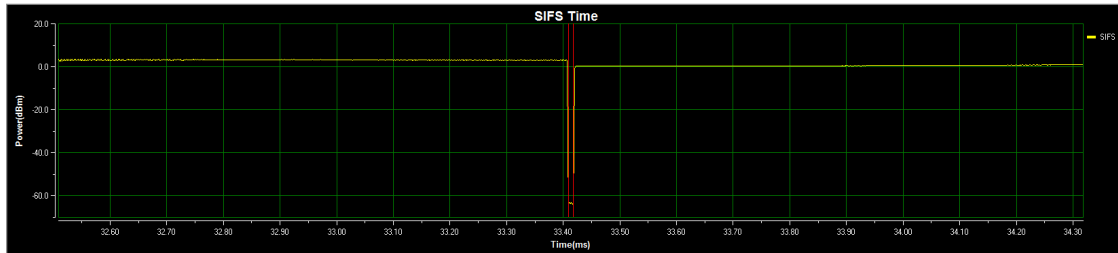
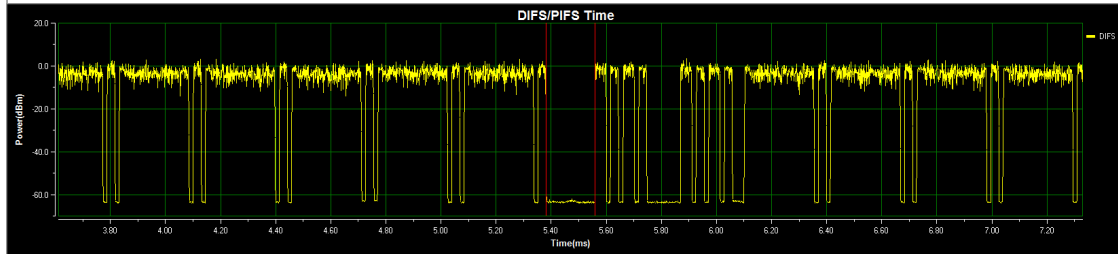

DIFS/PIFS(us): 177.00 SIFS(us): 9.00
Measured CCA(us): 159.00 Maximum CCA time should be between 18us ~ 160us

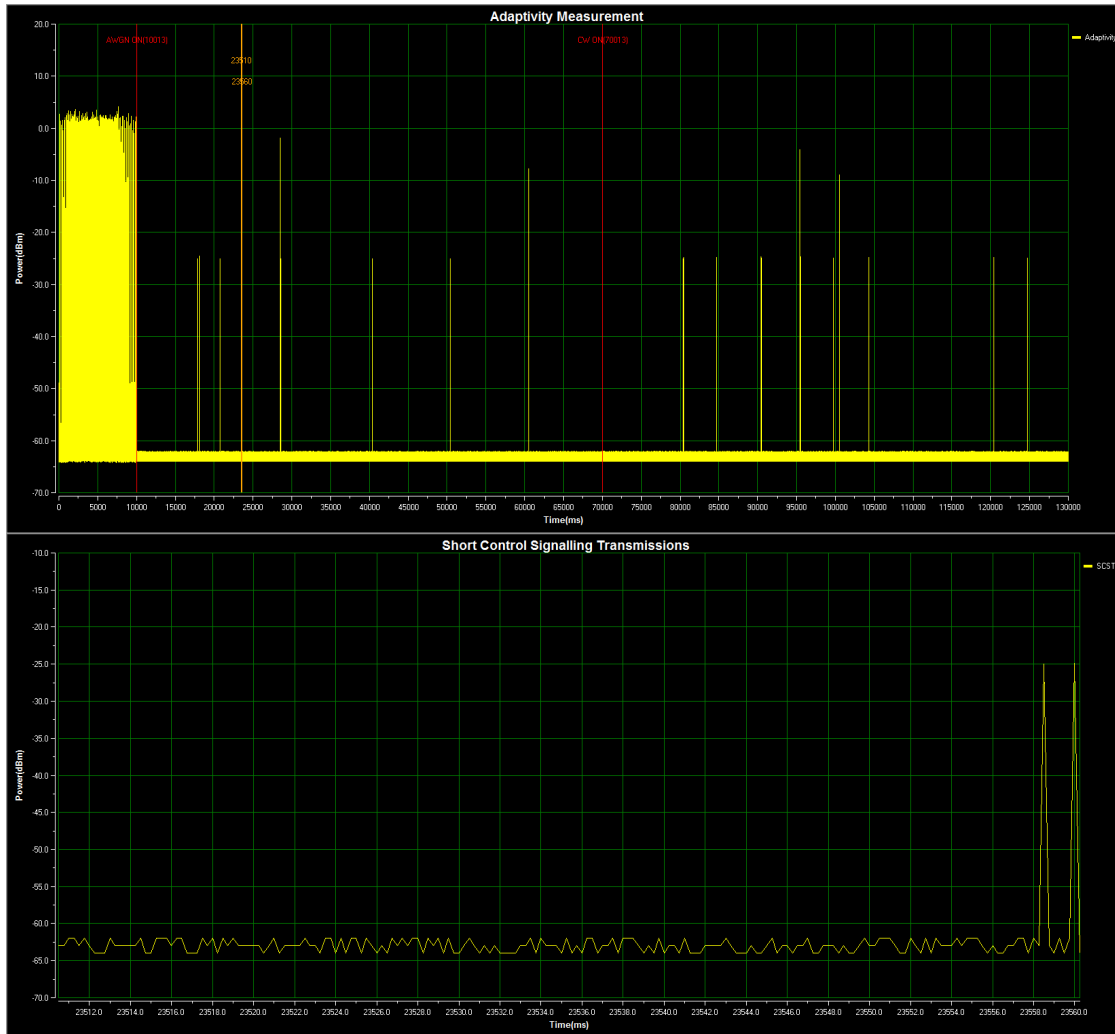

Duty Cycle (%):2.00 Short Control Signalling Transmissions Time (ms):1.00
Test Result:Pass

IEEE 802.11g Mode 2462 MHz

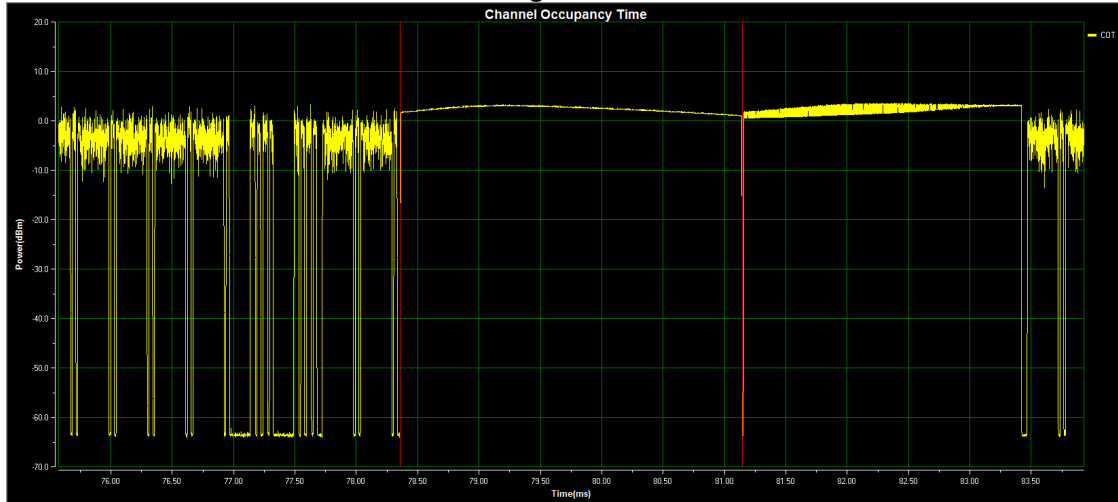

Max Channel Occupancy Time (ms): 2.79
Please make sure the COT less than 13ms, Or it will be failed

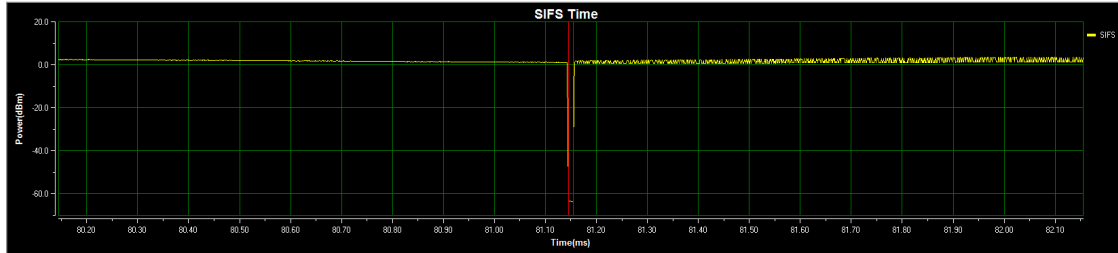
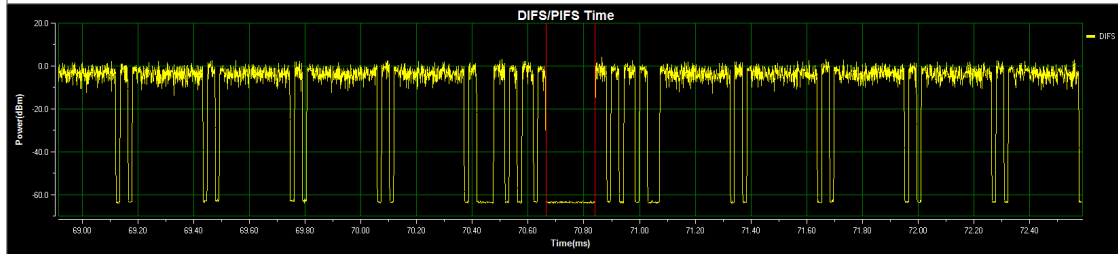

DIFS/PIFS(us):175.00 SIFS(us):10.00
Measured CCA(us):155.00 Maximum CCA time should be between 18us ~ 160us

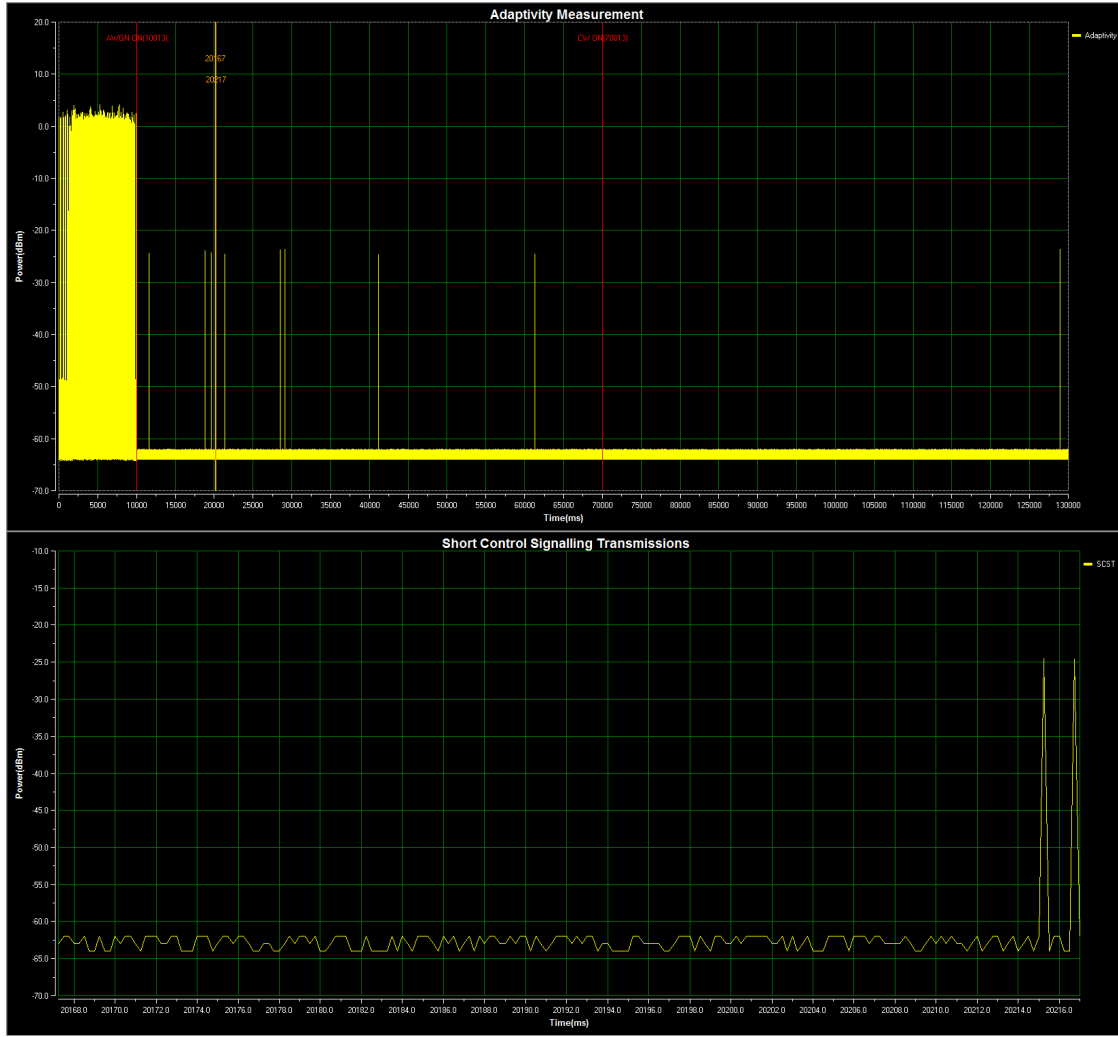

Duty Cycle (%):2.00 Short Control Signalling Transmissions Time (ms):1.00
Test Result:Pass

Test Mode:	TX Mode_ IEEE 802.11n(HT20) Mode
------------	----------------------------------

Channel Occupancy Time and Clear Channel Assessment Measured Results		
---	--	--

Freq.(MHz)	Channel Occupancy Time (ms)	Clear Channel Assessment (us)
2412	5.38	123
2462	5.32	141
Limit	13	18~160

Note: Channel Occupancy Time and Clear Channel Assessment follow as IEEE Std. 802.11-2012 and IEEE 802.11n-2012 Specification without restriction.

Adaptivity		
-------------------	--	--

Adaptivity Detection Threshold Level	2412 MHz	-65.47 dBm/MHz
	2462 MHz	-65.56 dBm/MHz
Freq.(MHz)	Short Control Signalling Transmissions (ms)	
2412	2.75	
2462	2.75	
Limit	5	
Result	Pass	

Note: Threshold Level = $-70 \text{ dBm/MHz} + 10 \times \log_{10} (100 \text{ mW}/P_{\text{out}}) + \text{EUT Antenna Gain}$
 (P_{out} in mW e.i.r.p.)
 Short Control Signalling Transmissions = 50 (ms) * Duty cycle (%)

IEEE 802.11n(HT20) Mode 2412 MHz

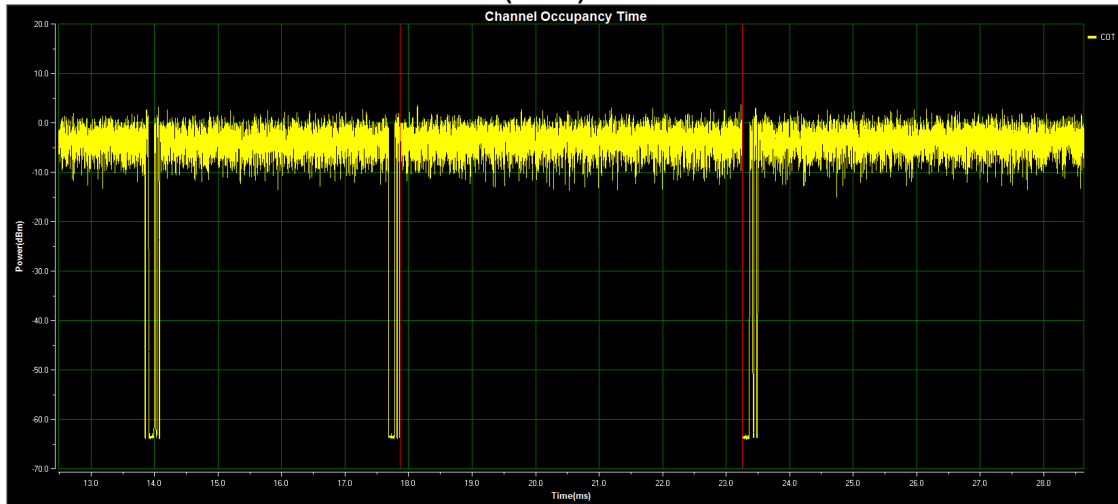

Max Channel Occupancy Time (ms): 5.38
Please make sure the COT less than 13ms, Or it will be failed

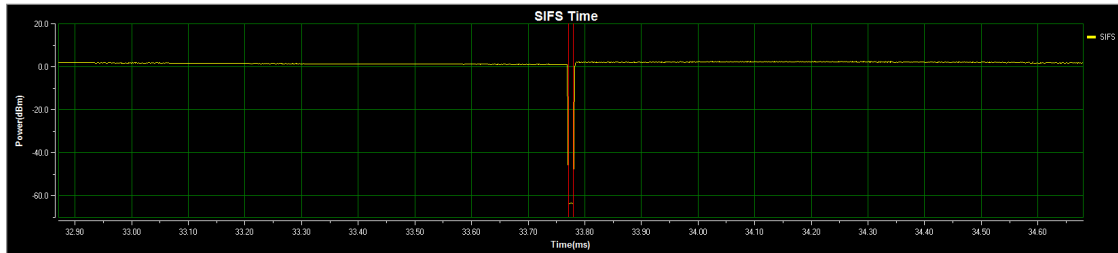
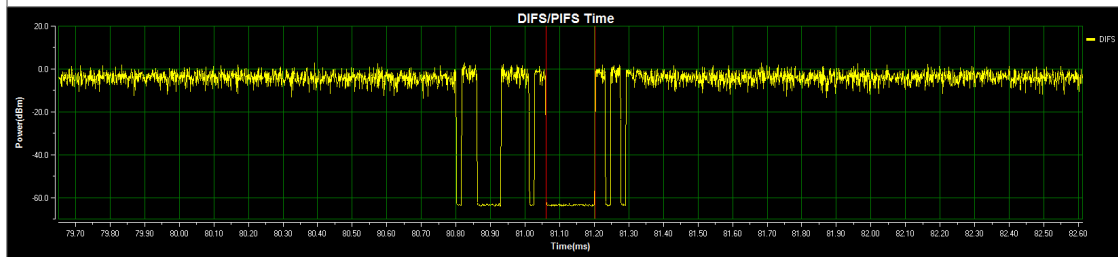

DIFS/PIFS(us): 141.00 SIFS(us): 9.00
Measured CCA(us): 123.00 Maximum CCA time should be between 18us ~ 160us

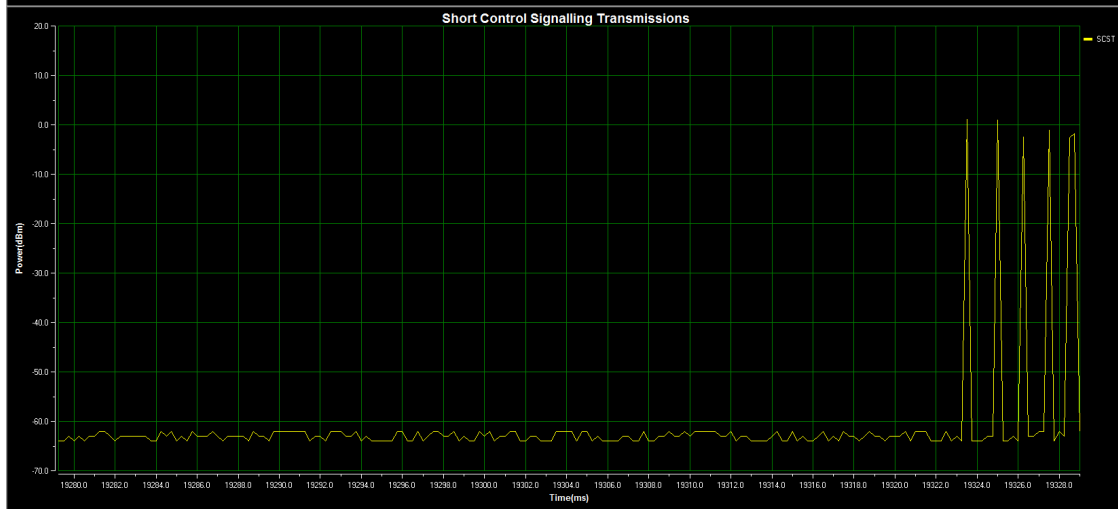
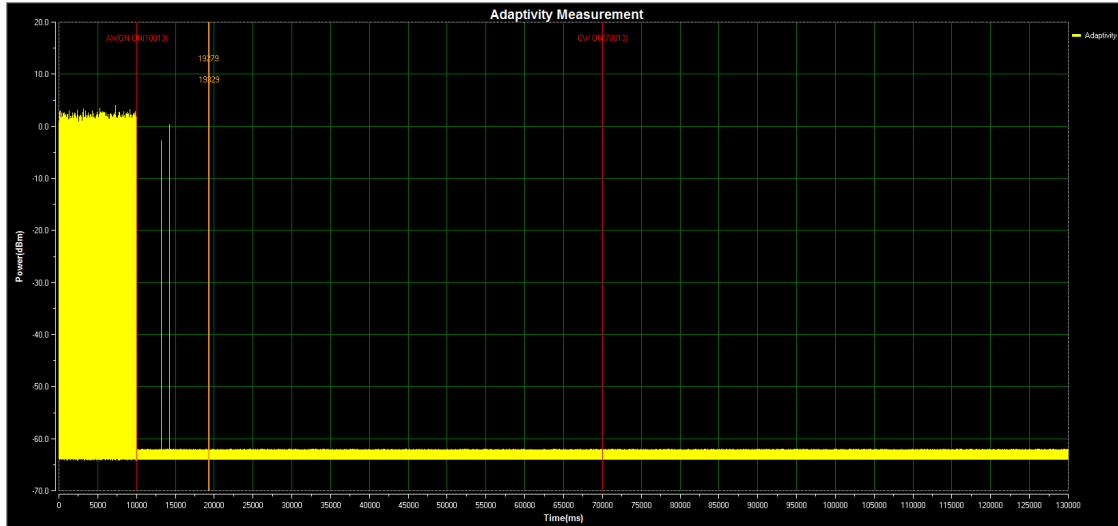

Duty Cycle (%):5.50 Short Control Signalling Transmissions Time (ms):2.75
Test Result:Pass

IEEE 802.11n(HT20) Mode 2462 MHz

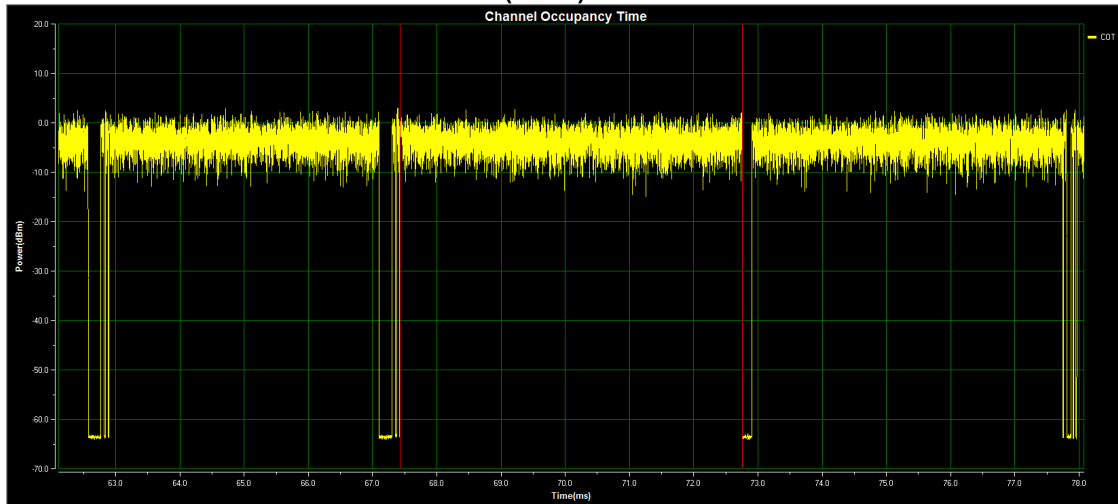

Max Channel Occupancy Time (ms): 5.32
Please make sure the COT less than 13ms, Or it will be failed

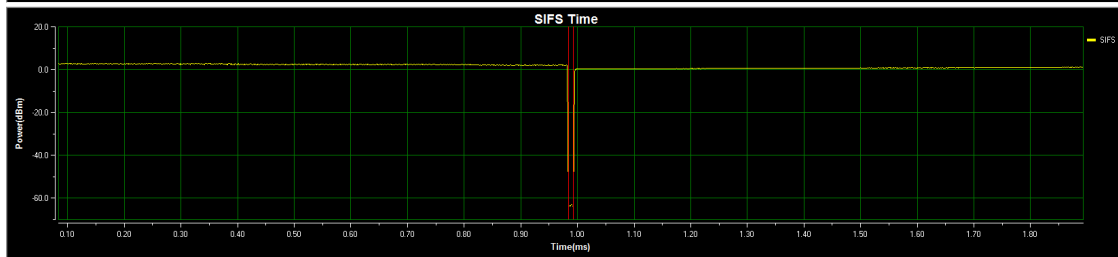
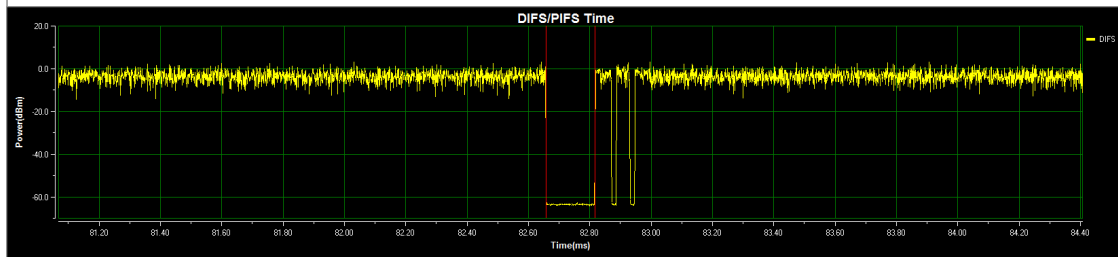

DIFS/PIFS(us): 159.00 SIFS(us): 9.00
Measured CCA(us): 141.00 Maximum CCA time should be between 18us ~ 160us

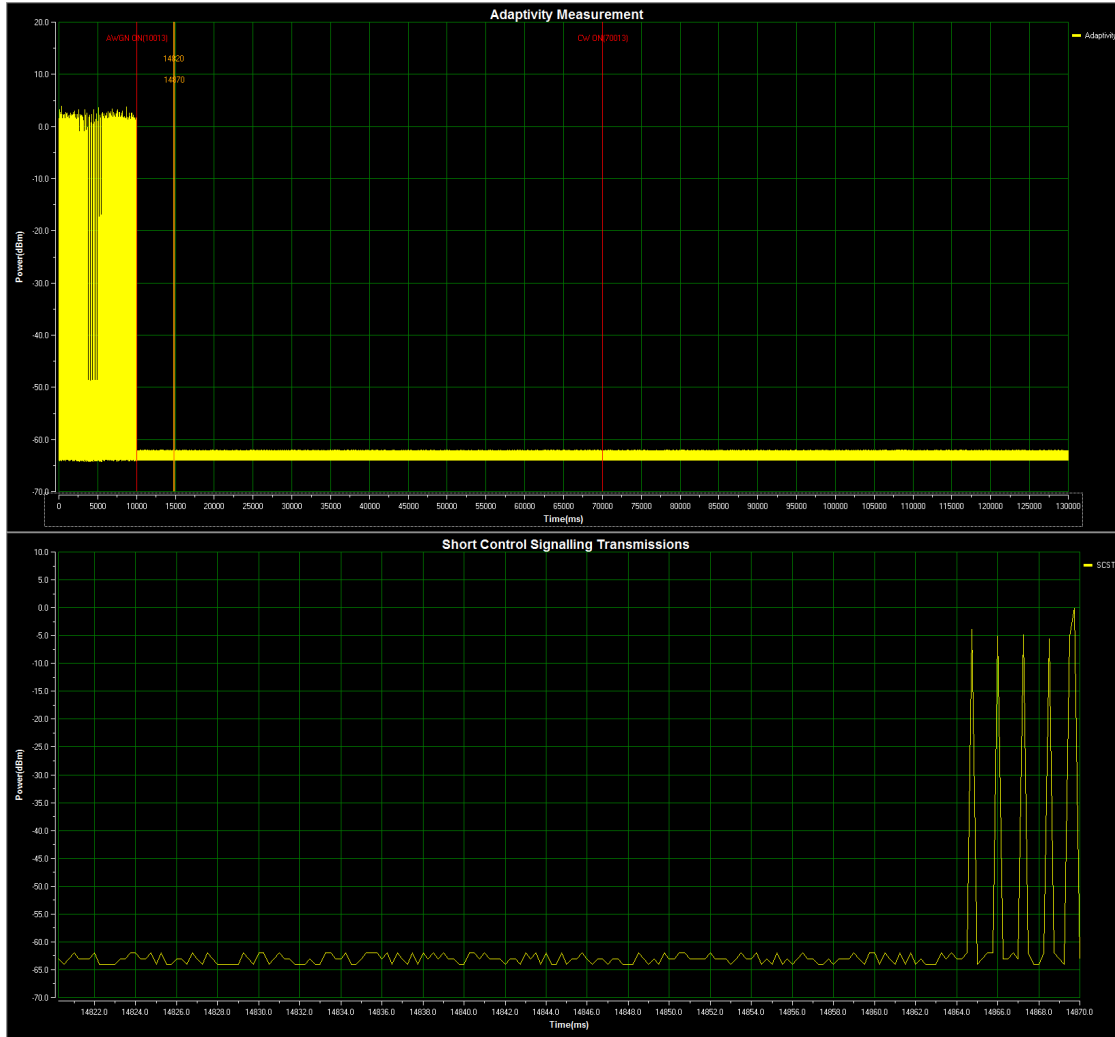

Duty Cycle (%): 5.50 Short Control Signalling Transmissions Time (ms): 2.75
Test Result: Pass

Test Mode:	TX Mode_ IEEE 802.11n(HT40) Mode
------------	----------------------------------

Channel Occupancy Time and Clear Channel Assessment Measured Results		
--	--	--

Freq.(MHz)	Channel Occupancy Time (ms)	Clear Channel Assessment (us)
2422	5.44	155
2452	5.44	146
Limit	13	18~160

Note: Channel Occupancy Time and Clear Channel Assessment follow as IEEE Std. 802.11-2012 and IEEE 802.11n-2012 Specification without restriction.

Adaptivity		
------------	--	--

Adaptivity Detection Threshold Level	2422 MHz	-65.62 dBm/MHz
	2452 MHz	-65.68 dBm/MHz
Freq.(MHz)	Short Control Signalling Transmissions (ms)	
2422	2.5	
2452	3.0	
Limit	5	
Result	Pass	

Note: Threshold Level = $-70 \text{ dBm/MHz} + 10 \times \log_{10} (100 \text{ mW}/P_{\text{out}}) + \text{EUT Antenna Gain}$
 (P_{out} in mW e.i.r.p.)
 Short Control Signalling Transmissions = 50 (ms) * Duty cycle (%)

IEEE 802.11n(HT40) Mode 2422 MHz

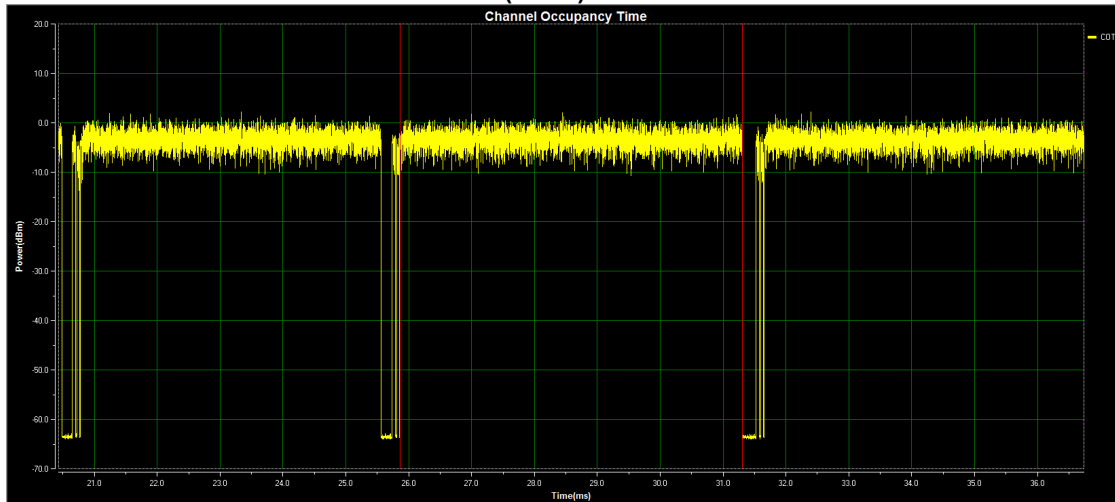

Max Channel Occupancy Time (ms): 5.44
Please make sure the COT less than 13ms, Or it will be failed

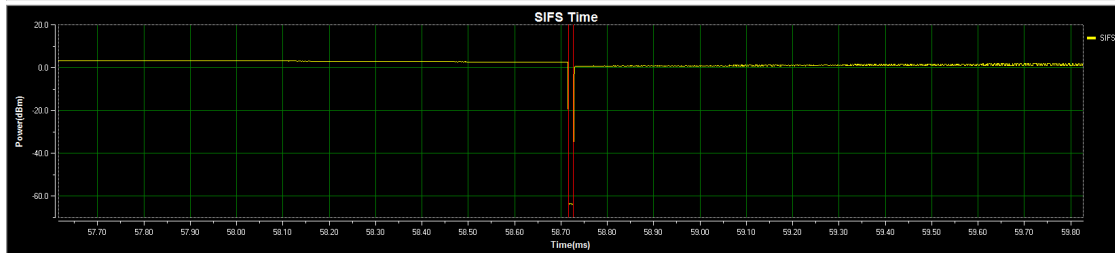
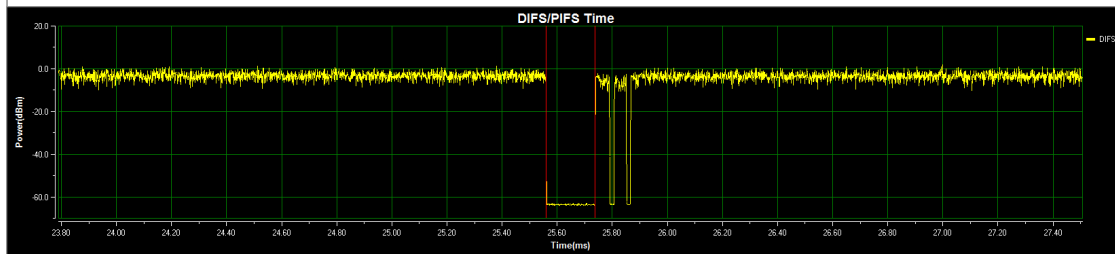

DIFS/PIFS(us): 177.00 SIFS(us): 11.00
Measured CCA(us): 155.00 Maximum CCA time should be between 18us ~ 160us

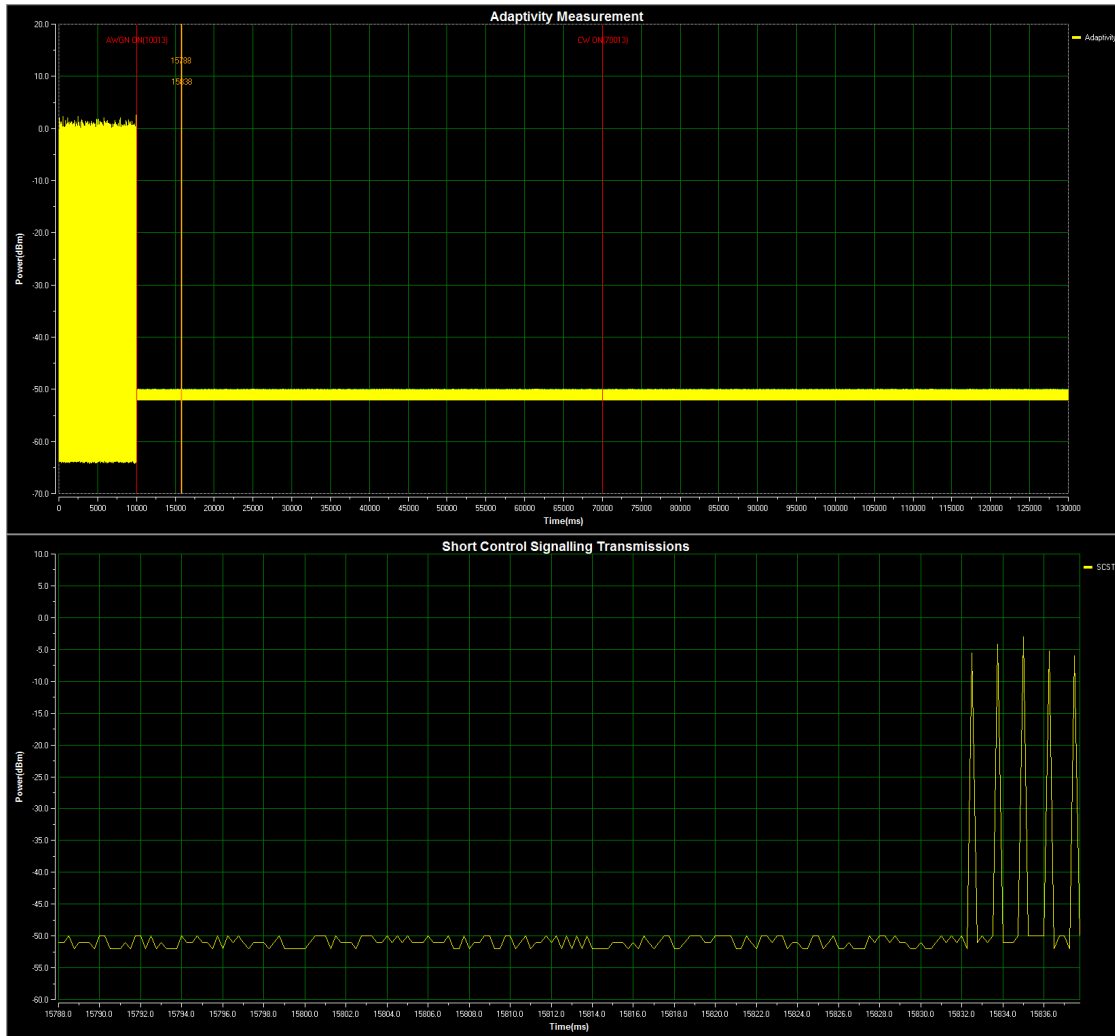

Duty Cycle(%):5.00 Short Control Signalling Transmissions Time(ms):2.50
Test Result:Pass

IEEE 802.11n(HT40) Mode 2452 MHz

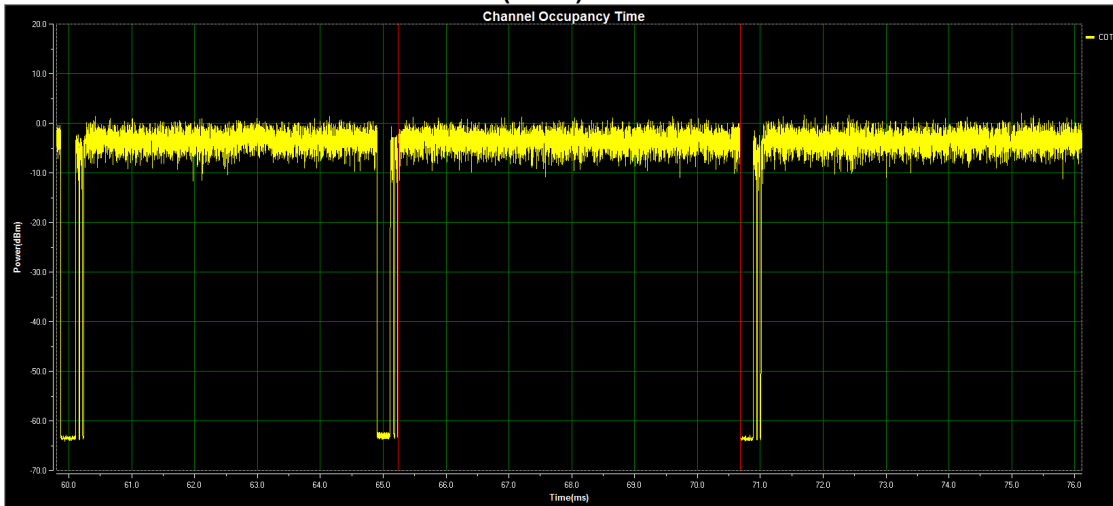

Max Channel Occupancy Time(ms):5.44
Please make sure the COT less than 13ms, Or it will be failed

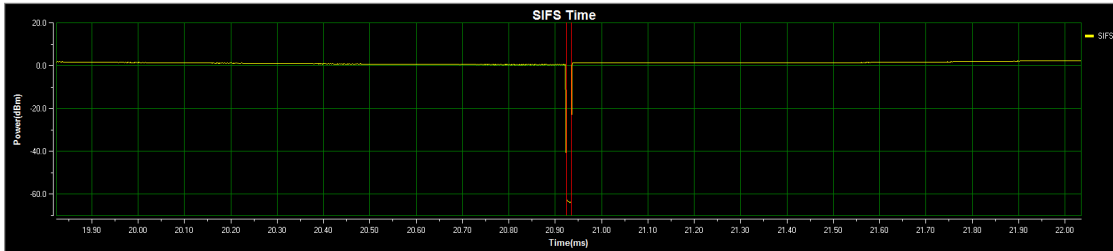
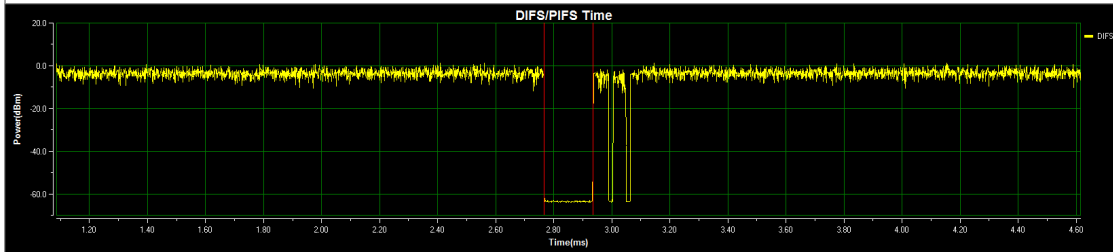

DIFS/PIFS(us):168.00 SIFS(us):11.00
Measured CCA(us):146.00 Maximum CCA time should be between 18us ~ 160us

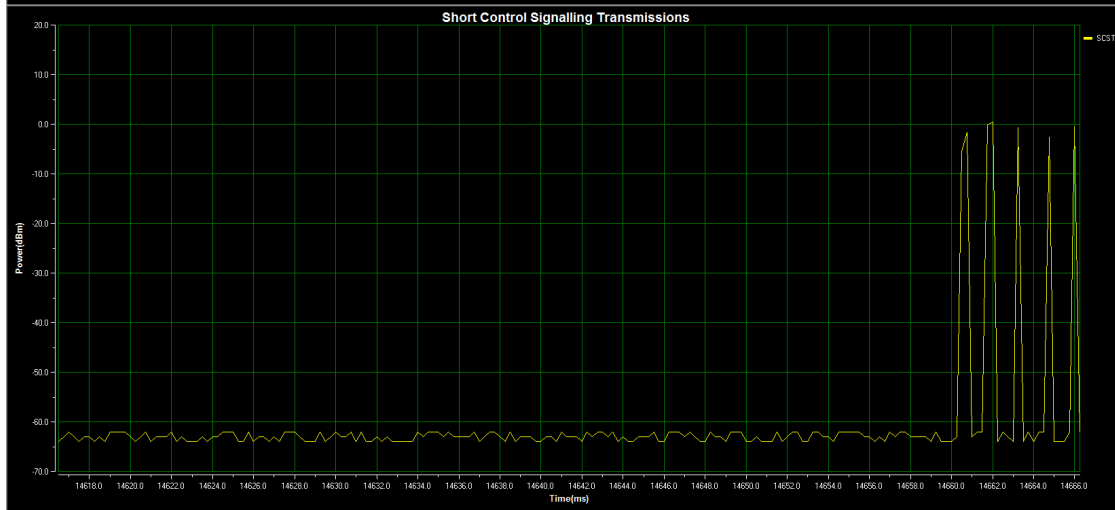

Duty Cycle (%): 6.00 Short Control Signalling Transmissions Time (ms): 3.00
Test Result: Pass

APPENDIX F - OCCUPIED CHANNEL BANDWIDTH

Test Mode: TX Mode_ IEEE 802.11b Mode

Frequency (MHz)	Occupied Channel Bandwidth (MHz)	F _L at 99% BW (MHz)	F _H at 99% BW (MHz)	Result
2412	13.498	2405.24	-	Pass
2462	13.491	-	2468.71	
N/A		F _L > 2400	F _H < 2483.5	

IEEE 802.11b Mode_2412 MHz

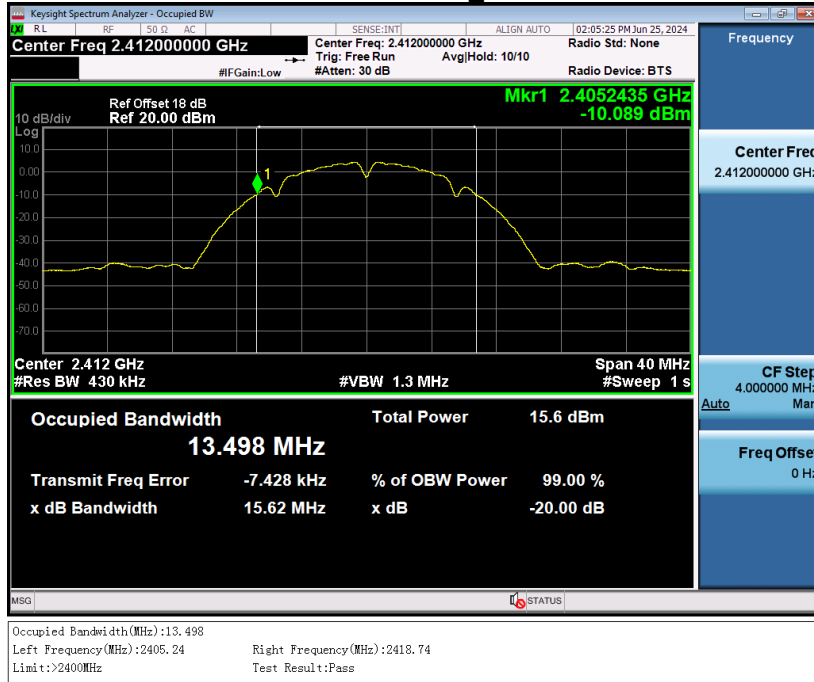

IEEE 802.11b Mode_2462 MHz

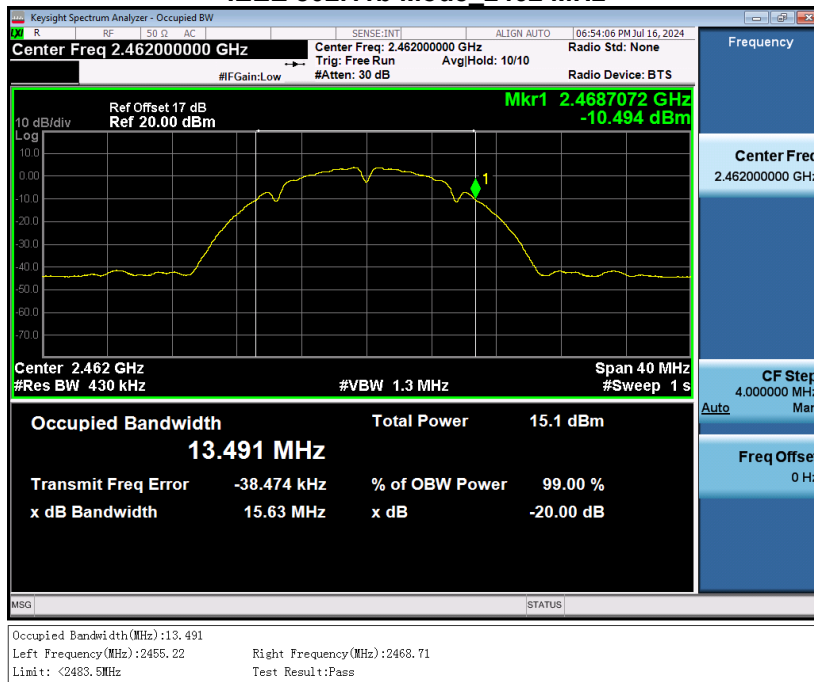

Test Mode: TX Mode_ IEEE 802.11g Mode

Frequency (MHz)	Occupied Channel Bandwidth (MHz)	F _L at 99% BW (MHz)	F _H at 99% BW (MHz)	Result
2412	16.447	2403.76	-	Pass
2462	16.459	-	2470.21	
N/A		F _L > 2400	F _H < 2483.5	

IEEE 802.11g Mode 2412 MHz

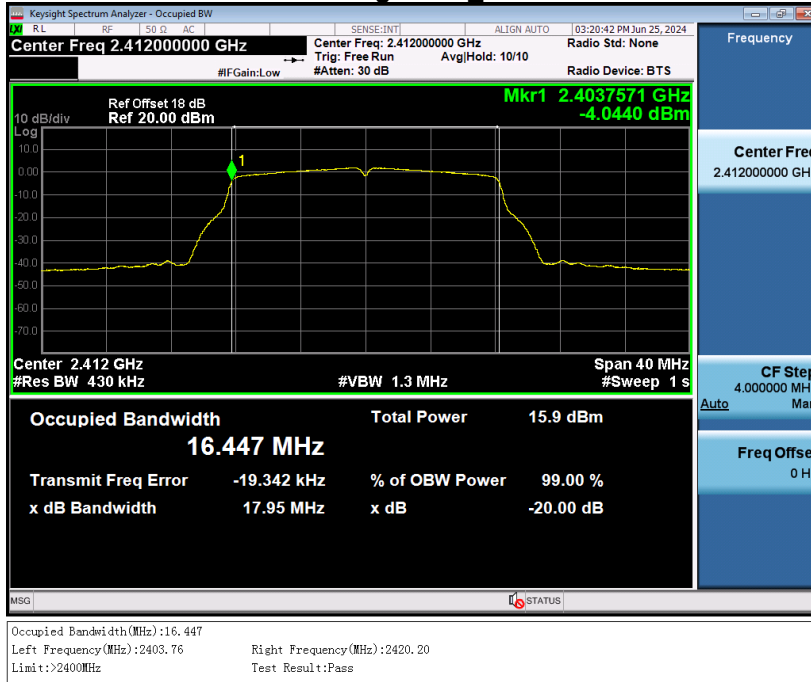

IEEE 802.11g Mode 2462 MHz

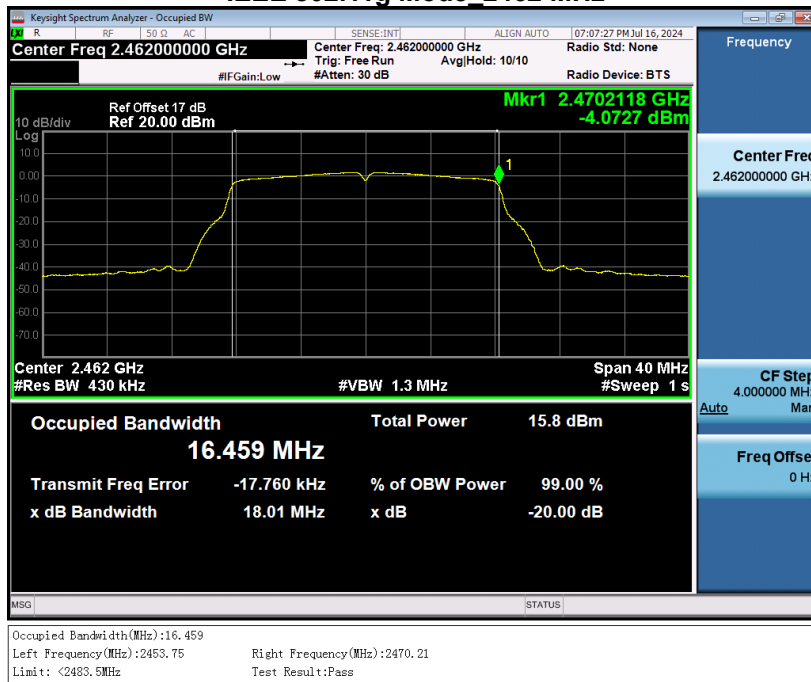

Test Mode: TX Mode_ IEEE 802.11n(HT20) Mode

Frequency (MHz)	Occupied Channel Bandwidth (MHz)	F _L at 99% BW (MHz)	F _H at 99% BW (MHz)	Result
2412	17.624	2403.17	-	Pass
2462	17.633	-	2470.80	
N/A		F _L > 2400	F _H < 2483.5	

IEEE 802.11n(HT20) Mode_ 2412 MHz

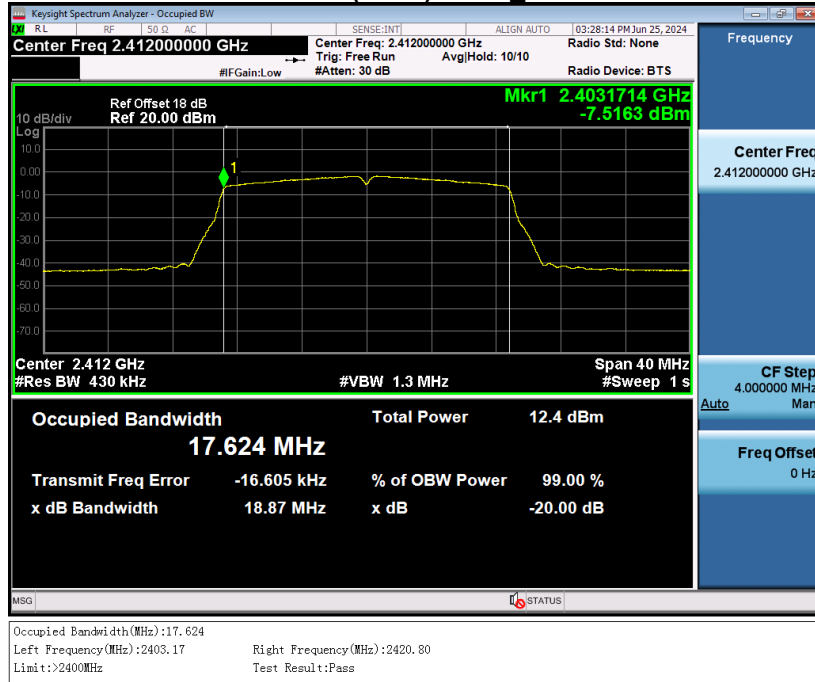

IEEE 802.11n(HT20) Mode_ 2462 MHz

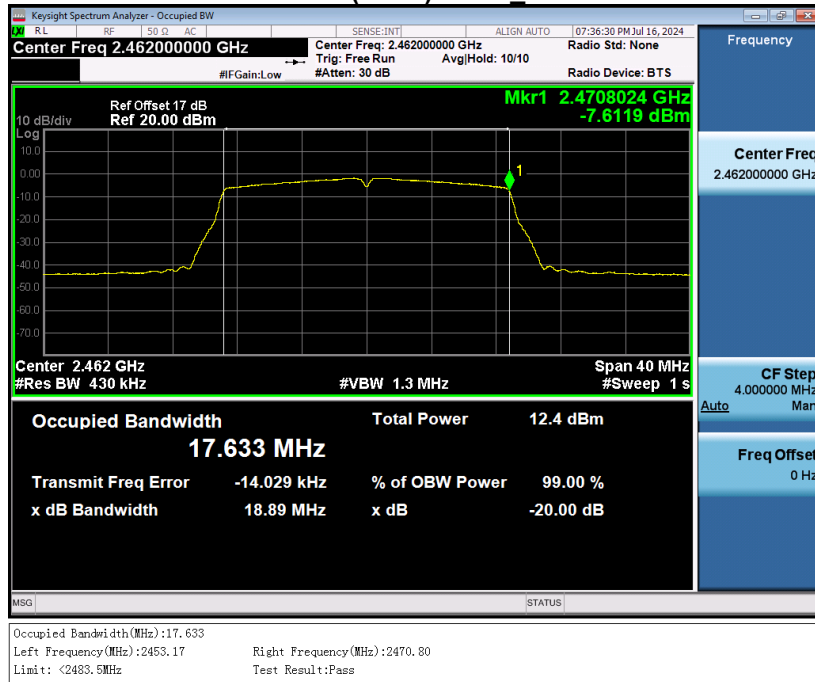

Test Mode: TX Mode_ IEEE 802.11n(HT40) Mode

Frequency (MHz)	Occupied Channel Bandwidth (MHz)	F _L at 99% BW (MHz)	F _H at 99% BW (MHz)	Result
2422	36.067	2403.97	-	Pass
2452	36.059	-	2470.01	
N/A		F _L > 2400	F _H < 2483.5	

IEEE 802.11n(HT40) Mode_ 2422 MHz

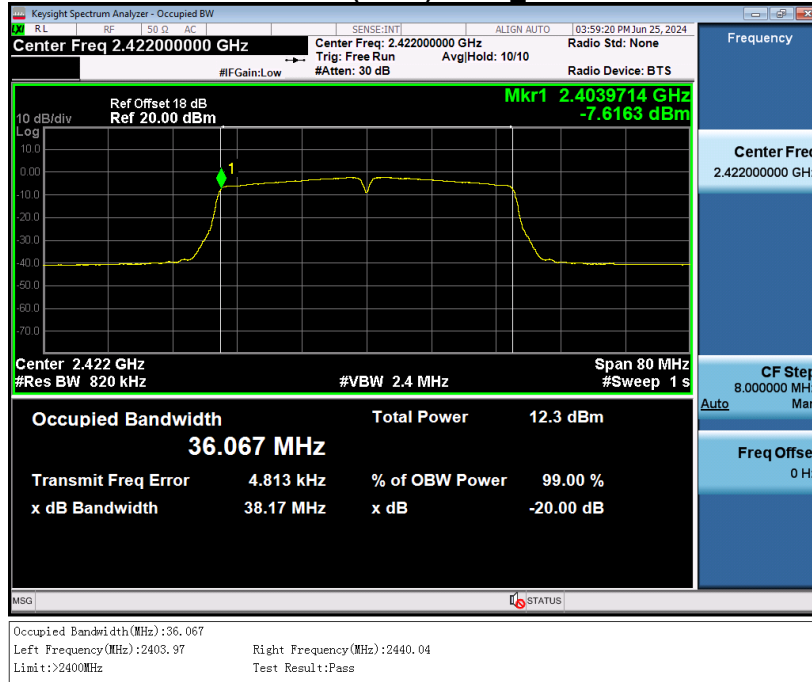

IEEE 802.11n(HT40) Mode_ 2452 MHz

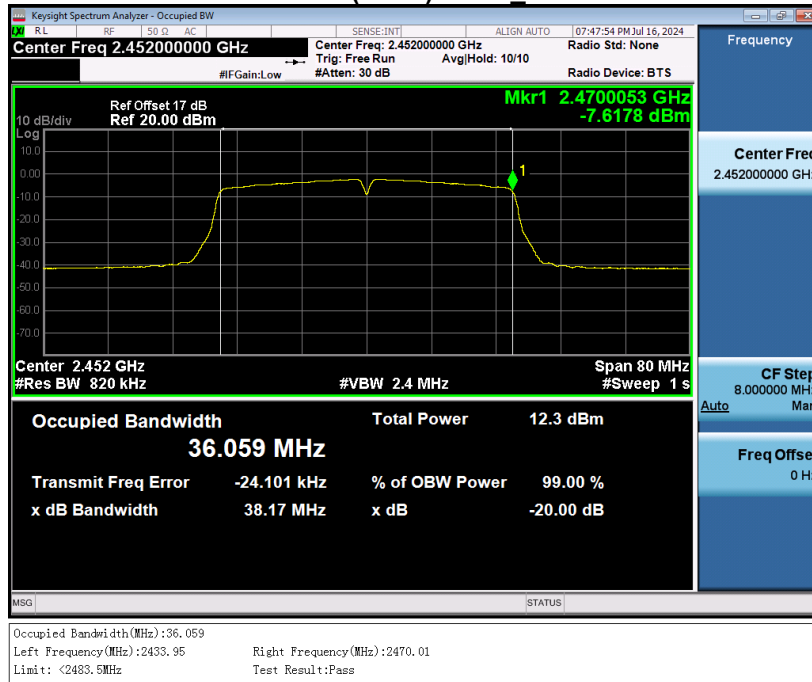

APPENDIX G - TRANSMITTER UNWANTED EMISSIONS IN THE OOB DOMAIN

Test Mode: TX Mode_ IEEE 802.11b Mode

IEEE 802.11b Mode_ 2412 MHz

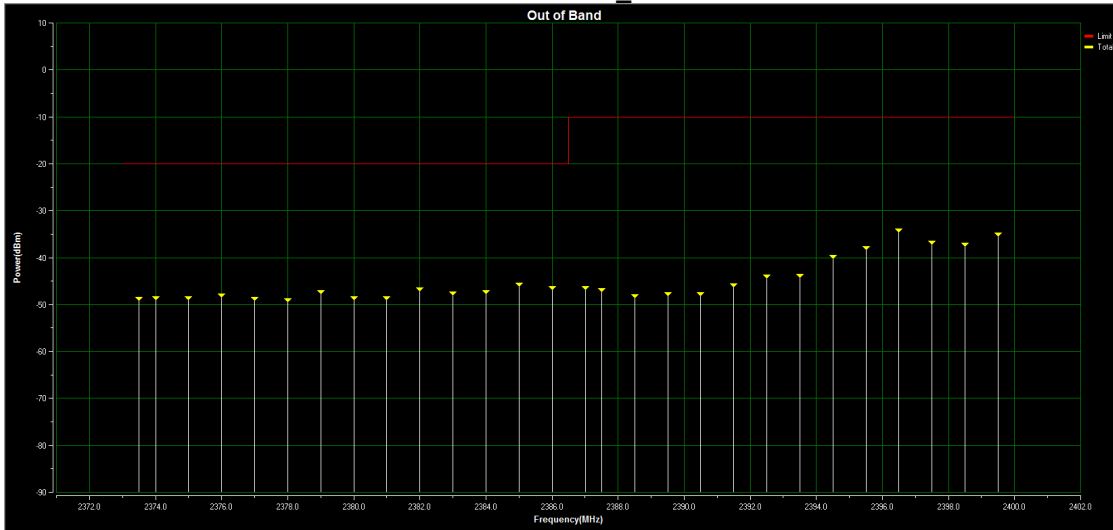

Test Result: Pass

IEEE 802.11b Mode_ 2462 MHz

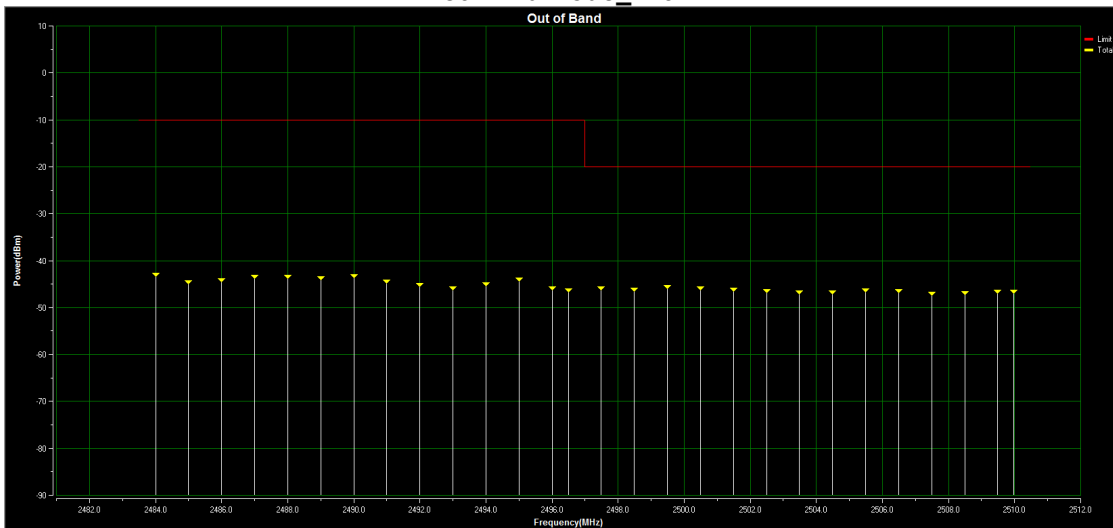

Test Result: Pass

Test Mode: TX Mode_ IEEE 802.11g Mode

IEEE 802.11g Mode_ 2412 MHz

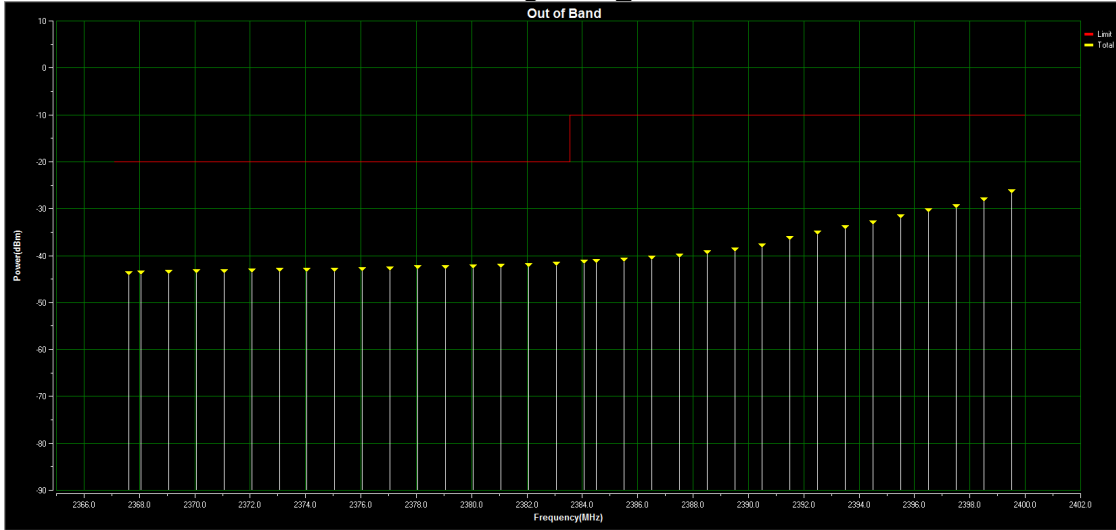

Test Result: Pass

IEEE 802.11g Mode_ 2462 MHz

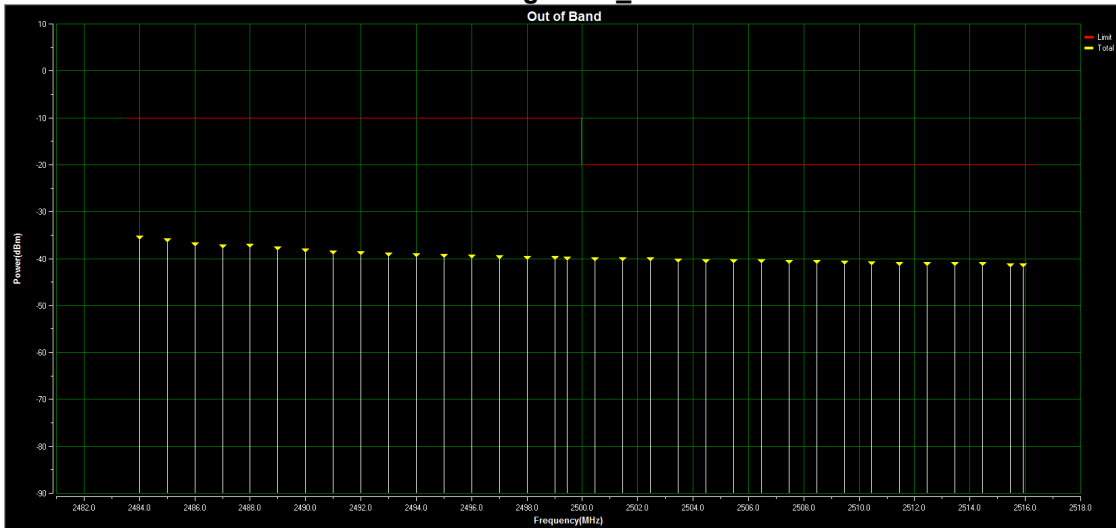

Test Result: Pass

Test Mode: TX Mode_ IEEE 802.11n(HT20) Mode

IEEE 802.11n(HT20) Mode_2412 MHz

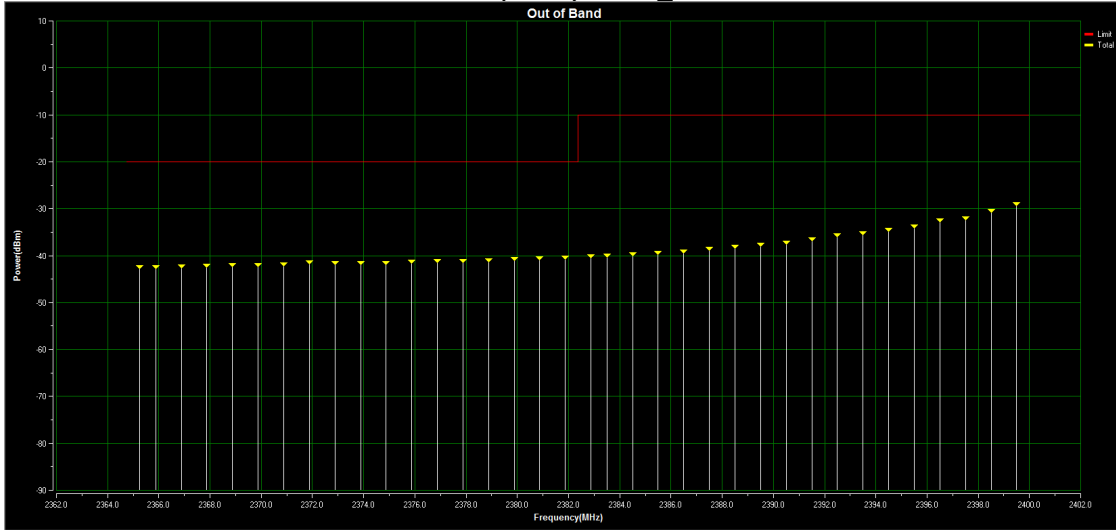

Test Result:Pass

IEEE 802.11n(HT20) Mode_2462 MHz

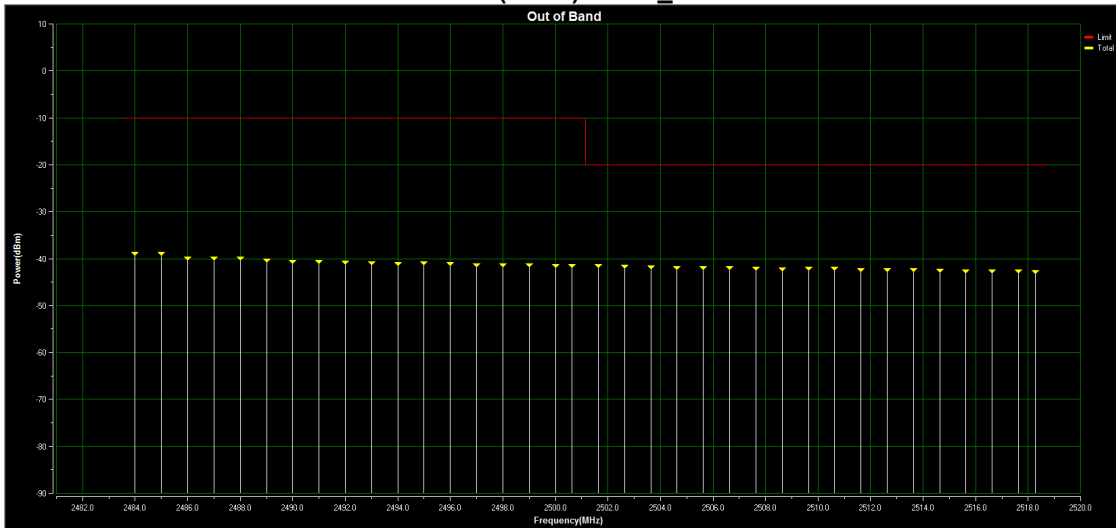

Test Result:Pass

Test Mode: TX Mode_ IEEE 802.11n(HT40) Mode

IEEE 802.11n(HT40) Mode_2422 MHz

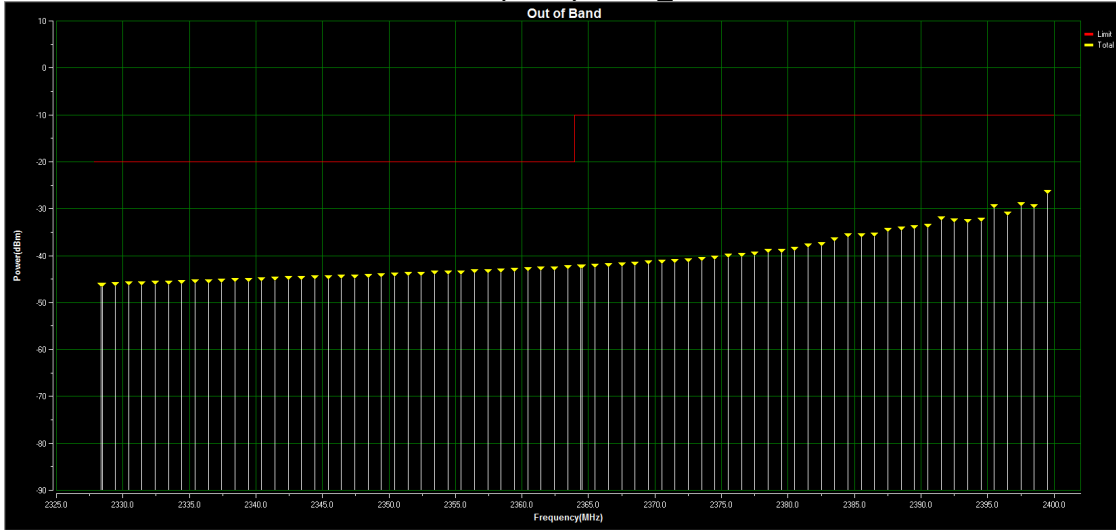

Test Result:Pass

IEEE 802.11n(HT40) Mode_2452 MHz

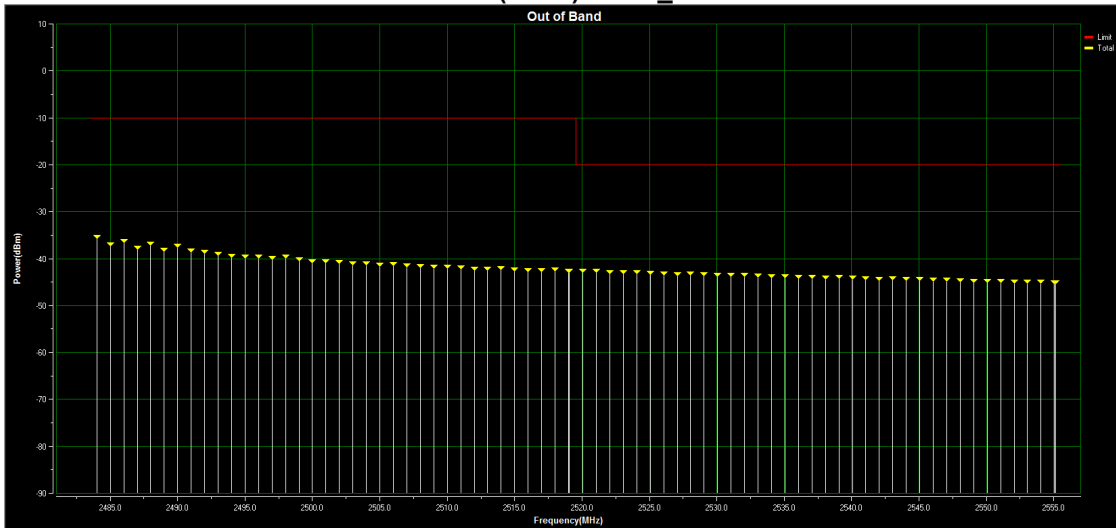

Test Result:Pass

APPENDIX H - TRANSMITTER UNWANTED EMISSIONS IN THE SPURIOUS DOMAIN

Test Mode	TX Mode IEEE 802.11g_2412 MHz	Polarization	Vertical
-----------	-------------------------------	--------------	----------

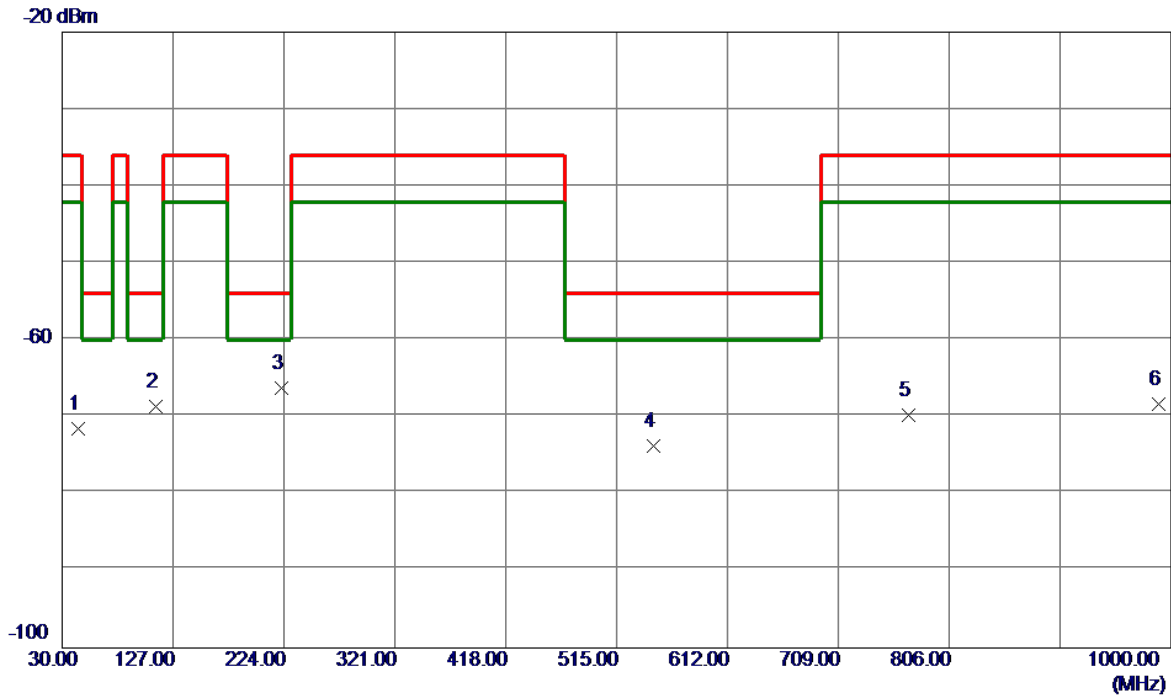

No.	Freq. MHz	Reading Level dBm	Correct Factor dB	Measure ment dBm	Limit dBm	Margin dB	Detector	Comment
1	44.1620	-72.14	0.62	-71.52	-36.00	-35.52	RMS	
2	111.7710	-65.09	-3.53	-68.62	-54.00	-14.62	RMS	
3 *	221.8660	-63.43	-2.82	-66.25	-54.00	-12.25	RMS	
4	546.9130	-77.55	3.71	-73.84	-54.00	-19.84	RMS	
5	770.3040	-77.01	7.23	-69.78	-36.00	-33.78	RMS	
6	988.8450	-77.97	9.63	-68.34	-36.00	-32.34	RMS	

Test Mode	TX Mode IEEE 802.11g_2412 MHz	Polarization	Horizontal
-----------	-------------------------------	--------------	------------

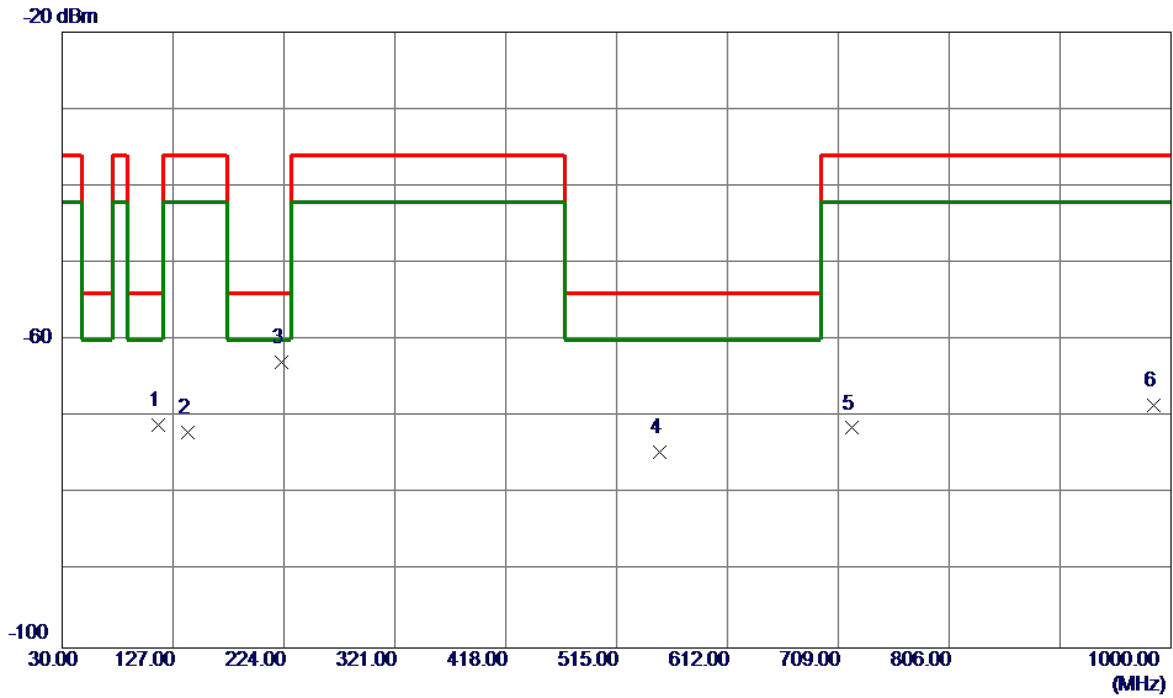

No.	Freq. MHz	Reading Level dBm	Correct Factor dB	Measure ment dBm	Limit dBm	Margin dB	Detector	Comment
1	114.2930	-67.25	-3.79	-71.04	-54.00	-17.04	RMS	
2	140.0950	-72.85	0.79	-72.06	-36.00	-36.06	RMS	
3 *	221.7690	-60.66	-2.22	-62.88	-54.00	-8.88	RMS	
4	552.4420	-78.51	4.00	-74.51	-54.00	-20.51	RMS	
5	720.4460	-77.70	6.26	-71.44	-36.00	-35.44	RMS	
6	985.1590	-78.45	10.01	-68.44	-36.00	-32.44	RMS	

Test Mode	TX Mode IEEE 802.11g_2462 MHz	Polarization	Vertical
-----------	-------------------------------	--------------	----------

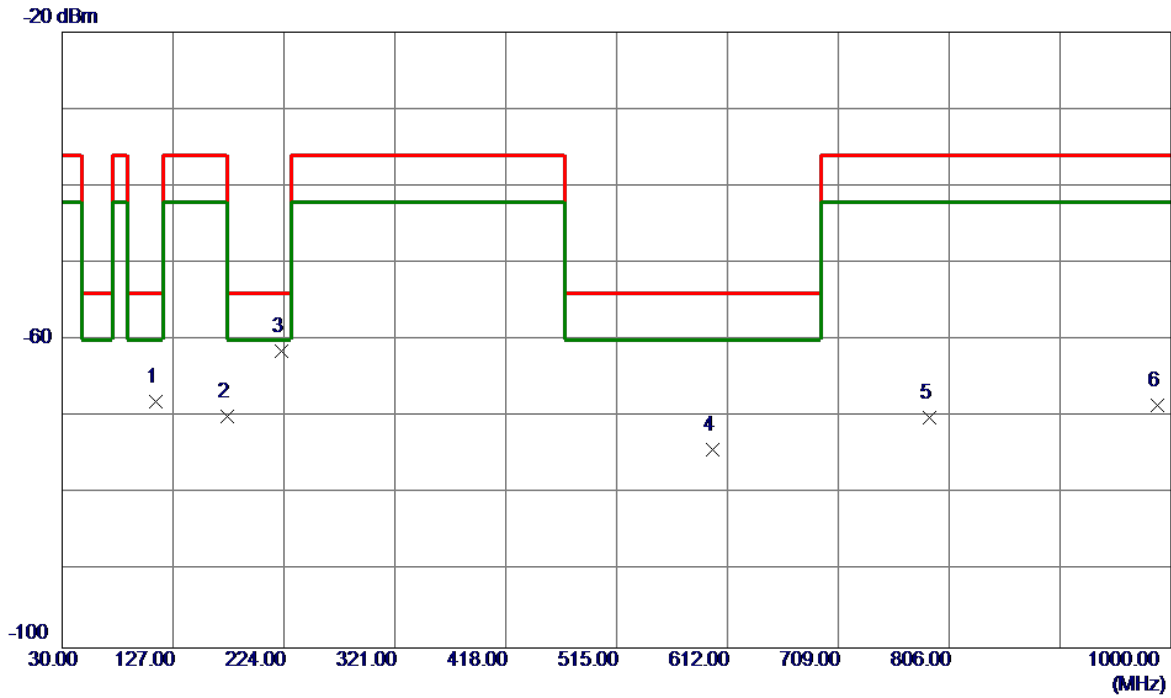

No.	Freq. MHz	Reading Level dBm	Correct Factor dB	Measure ment dBm	Limit dBm	Margin dB	Detector	Comment
1	112.0620	-64.55	-3.51	-68.06	-54.00	-14.06	RMS	
2	174.3359	-68.65	-1.24	-69.89	-54.00	-15.89	RMS	
3 *	221.7690	-58.59	-2.83	-61.42	-54.00	-7.42	RMS	
4	599.0989	-79.12	4.92	-74.20	-54.00	-20.20	RMS	
5	788.7340	-77.76	7.66	-70.10	-36.00	-34.10	RMS	
6	987.6810	-78.16	9.63	-68.53	-36.00	-32.53	RMS	

Test Mode	TX Mode IEEE 802.11g_2462 MHz	Polarization	Horizontal
-----------	-------------------------------	--------------	------------

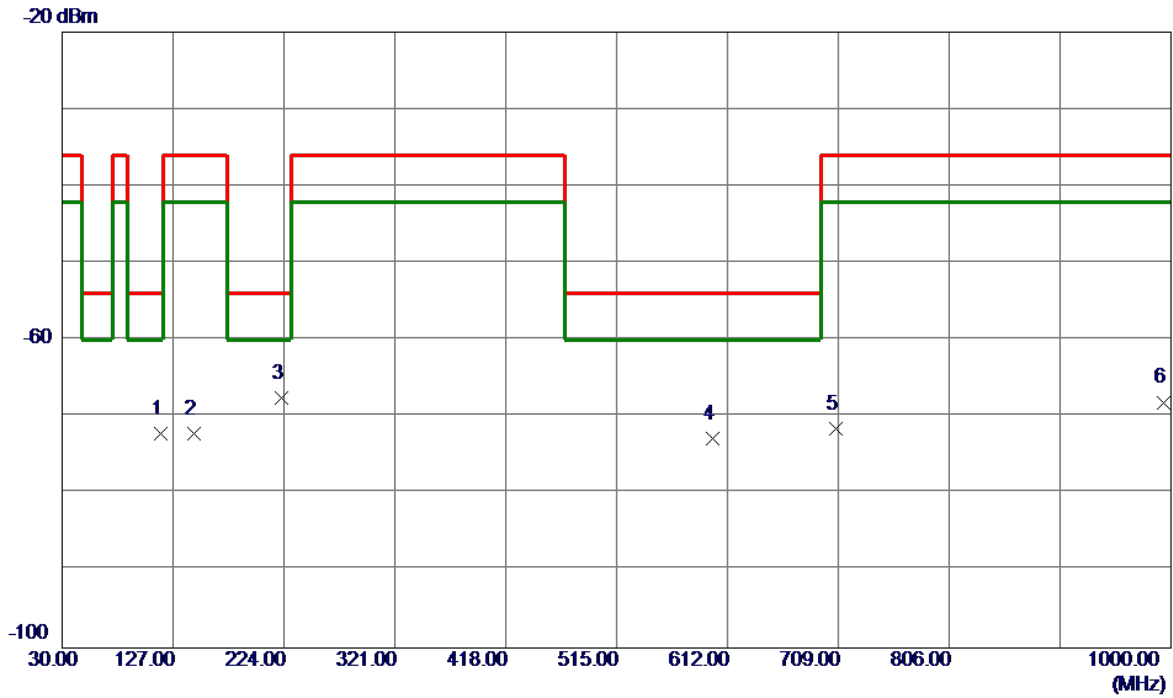

No.	Freq. MHz	Reading Level dBm	Correct Factor dB	Measure ment dBm	Limit dBm	Margin dB	Detector	Comment
1	116.7180	-68.71	-3.40	-72.11	-54.00	-18.11	RMS	
2	145.2360	-73.13	0.98	-72.15	-36.00	-36.15	RMS	
3 *	221.7690	-65.26	-2.22	-67.48	-54.00	-13.48	RMS	
4	598.8080	-77.46	4.69	-72.77	-54.00	-18.77	RMS	
5	706.5750	-77.73	6.16	-71.57	-36.00	-35.57	RMS	
6	993.6950	-78.19	10.11	-68.08	-36.00	-32.08	RMS	

Test Mode	TX Mode IEEE 802.11b_2412 MHz	Polarization	Vertical
-----------	-------------------------------	--------------	----------

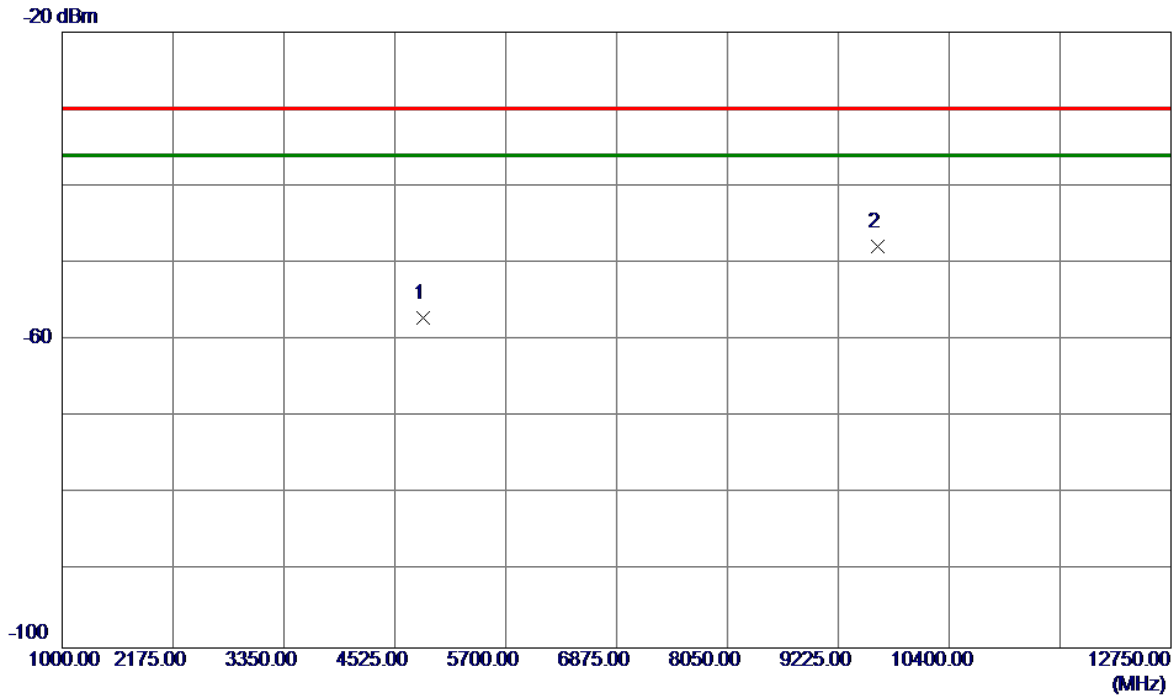

No.	Freq. MHz	Reading Level dBm	Correct Factor dB	Measure ment dBm	Limit dBm	Margin dB	Detector	Comment
1	4824.0379	-57.96	0.91	-57.05	-30.00	-27.05	RMS	
2 *	9648.0000	-53.86	6.08	-47.78	-30.00	-17.78	RMS	

Test Mode	TX Mode IEEE 802.11b_2412 MHz	Polarization	Horizontal
-----------	-------------------------------	--------------	------------

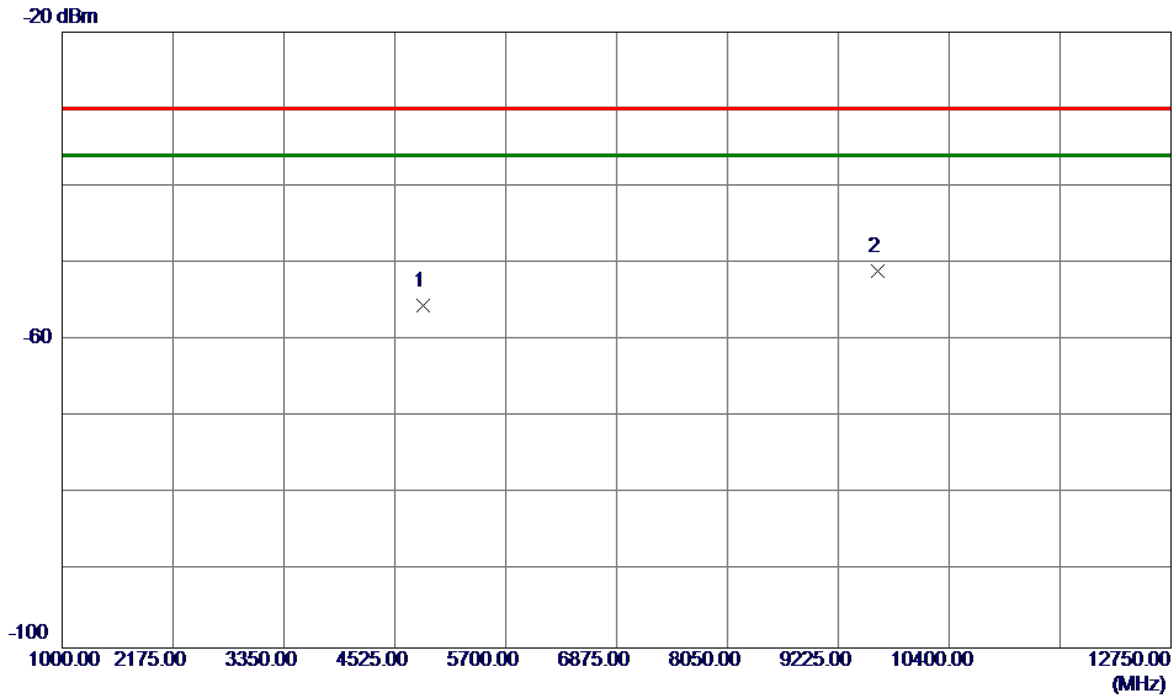

No.	Freq. MHz	Reading Level dBm	Correct Factor dB	Measure ment dBm	Limit dBm	Margin dB	Detector	Comment
1	4824.0379	-56.87	1.31	-55.56	-30.00	-25.56	RMS	
2 *	9648.0000	-57.30	6.29	-51.01	-30.00	-21.01	RMS	

Test Mode	TX Mode IEEE 802.11b_2462 MHz	Polarization	Vertical
-----------	-------------------------------	--------------	----------

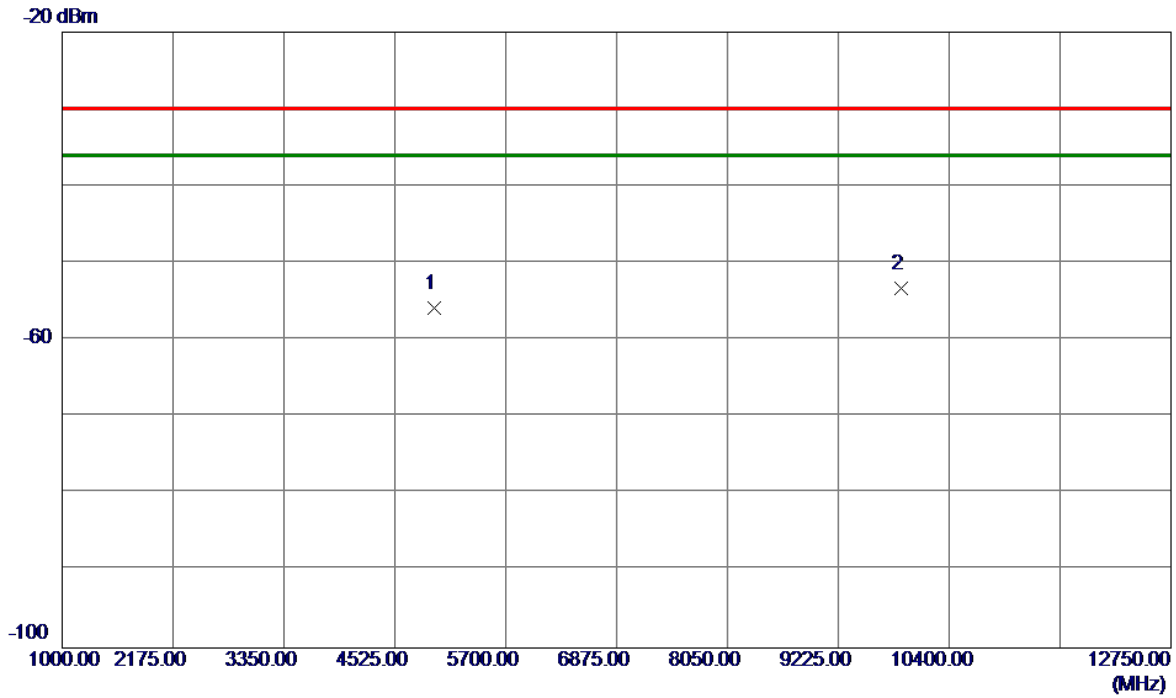

No.	Freq. MHz	Reading Level dBm	Correct Factor dB	Measure ment dBm	Limit dBm	Margin dB	Detector	Comment
1	4943.8870	-56.82	0.99	-55.83	-30.00	-25.83	RMS	
2 *	9887.7000	-59.89	6.58	-53.31	-30.00	-23.31	RMS	

Test Mode	TX Mode IEEE 802.11b_2462 MHz	Polarization	Horizontal
-----------	-------------------------------	--------------	------------

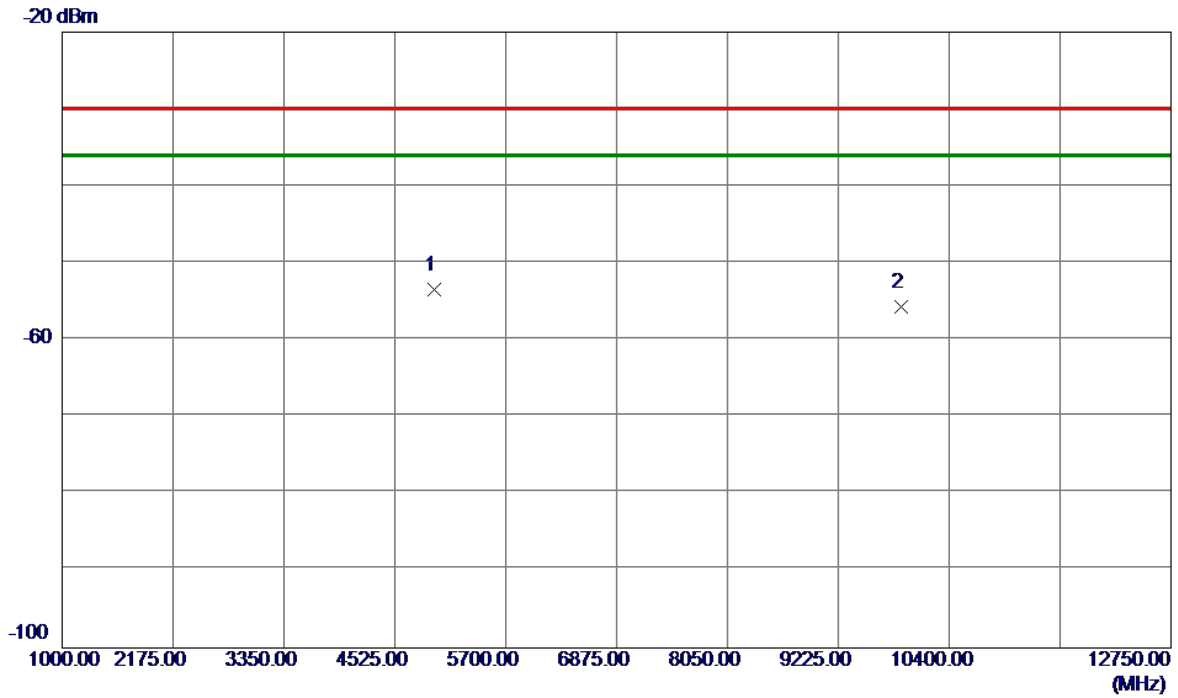

No.	Freq. MHz	Reading Level dBm	Correct Factor dB	Measure ment dBm	Limit dBm	Margin dB	Detector	Comment
1 *	4943.8870	-54.73	1.35	-53.38	-30.00	-23.38	RMS	
2	9888.2880	-62.43	6.81	-55.62	-30.00	-25.62	RMS	

Test Mode	TX Mode IEEE 802.11g_2412 MHz	Polarization	Vertical
-----------	-------------------------------	--------------	----------

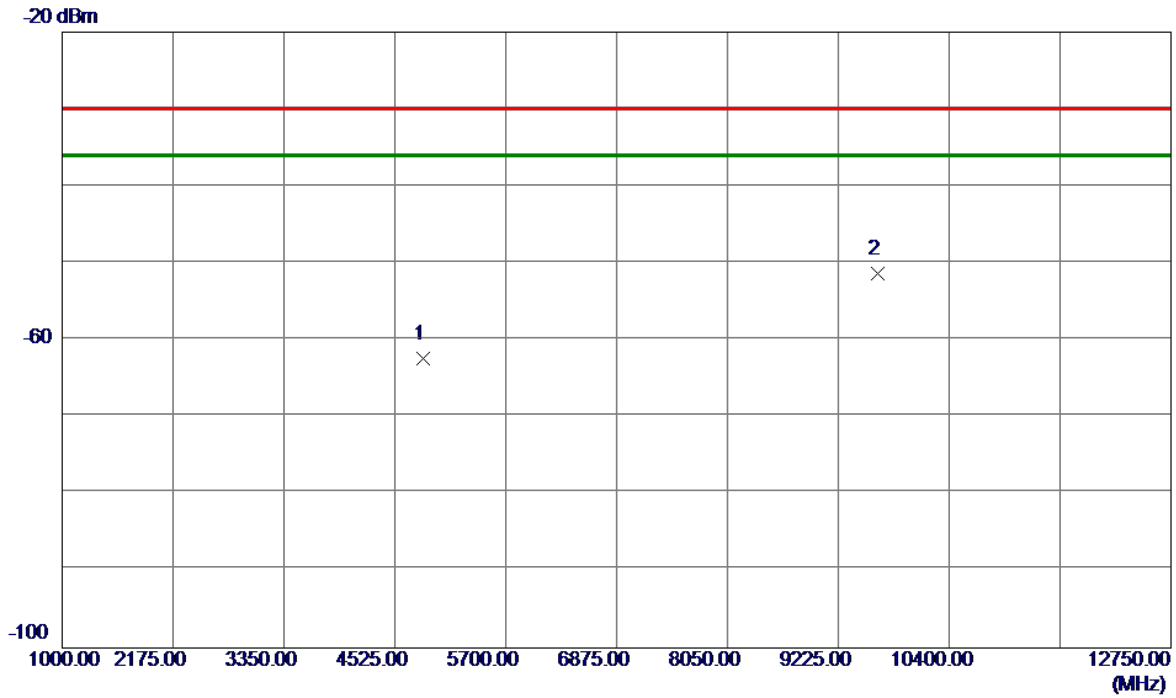

No.	Freq. MHz	Reading Level dBm	Correct Factor dB	Measure ment dBm	Limit dBm	Margin dB	Detector	Comment
1	4824.6250	-63.35	0.91	-62.44	-30.00	-32.44	RMS	
2 *	9648.0000	-57.39	6.08	-51.31	-30.00	-21.31	RMS	

Test Mode	TX Mode IEEE 802.11g_2412 MHz	Polarization	Horizontal
-----------	-------------------------------	--------------	------------

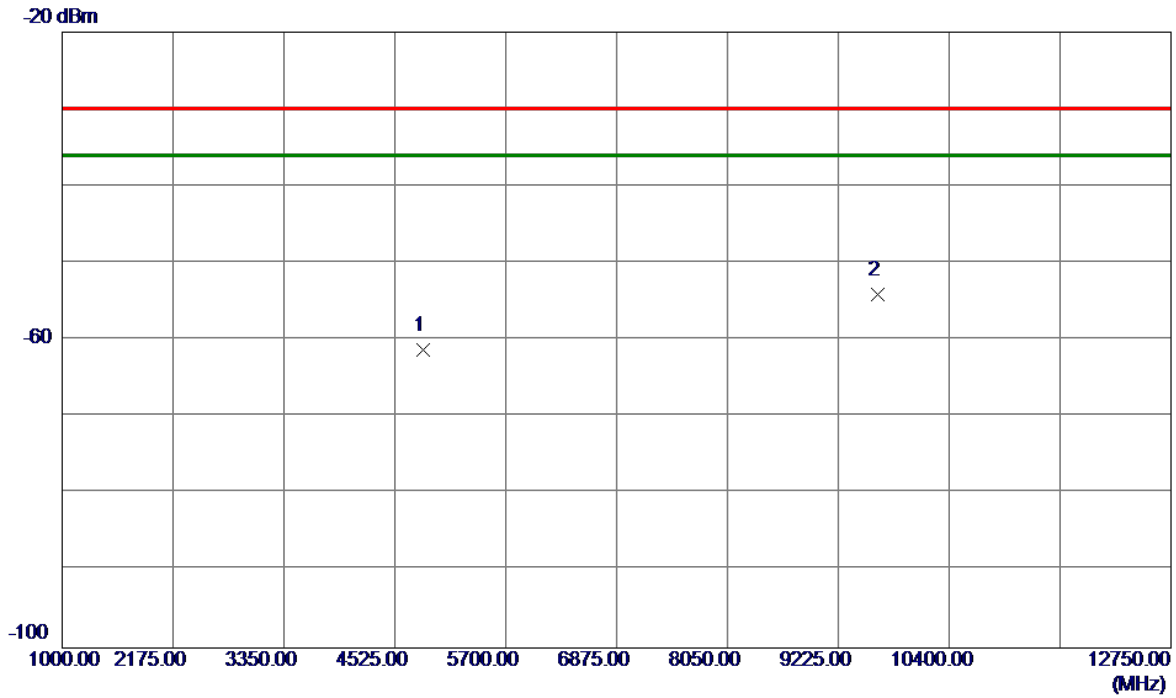

No.	Freq. MHz	Reading Level dBm	Correct Factor dB	Measure ment dBm	Limit dBm	Margin dB	Detector	Comment
1	4821.6880	-62.55	1.31	-61.24	-30.00	-31.24	RMS	
2 *	9648.0000	-60.32	6.29	-54.03	-30.00	-24.03	RMS	

Test Mode	TX Mode IEEE 802.11g_2462 MHz	Polarization	Vertical
-----------	-------------------------------	--------------	----------

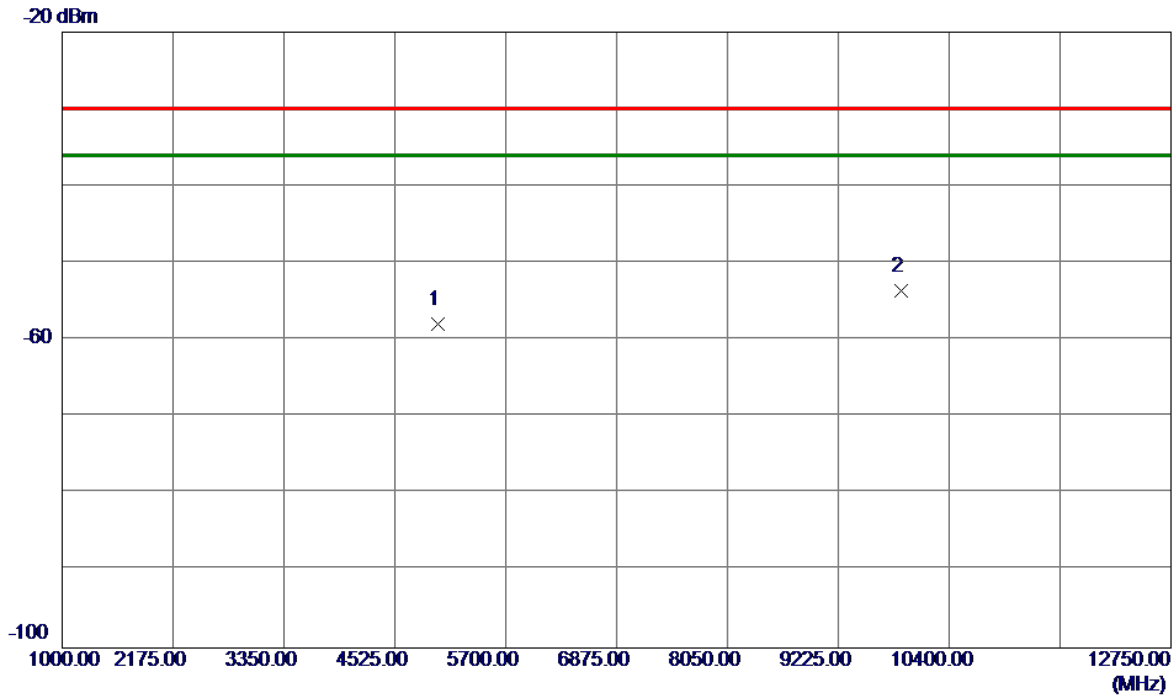

No.	Freq. MHz	Reading Level dBm	Correct Factor dB	Measure ment dBm	Limit dBm	Margin dB	Detector	Comment
1	4982.6629	-58.87	1.01	-57.86	-30.00	-27.86	RMS	
2 *	9887.7000	-60.24	6.58	-53.66	-30.00	-23.66	RMS	

Test Mode	TX Mode IEEE 802.11g_2462 MHz	Polarization	Horizontal
-----------	-------------------------------	--------------	------------

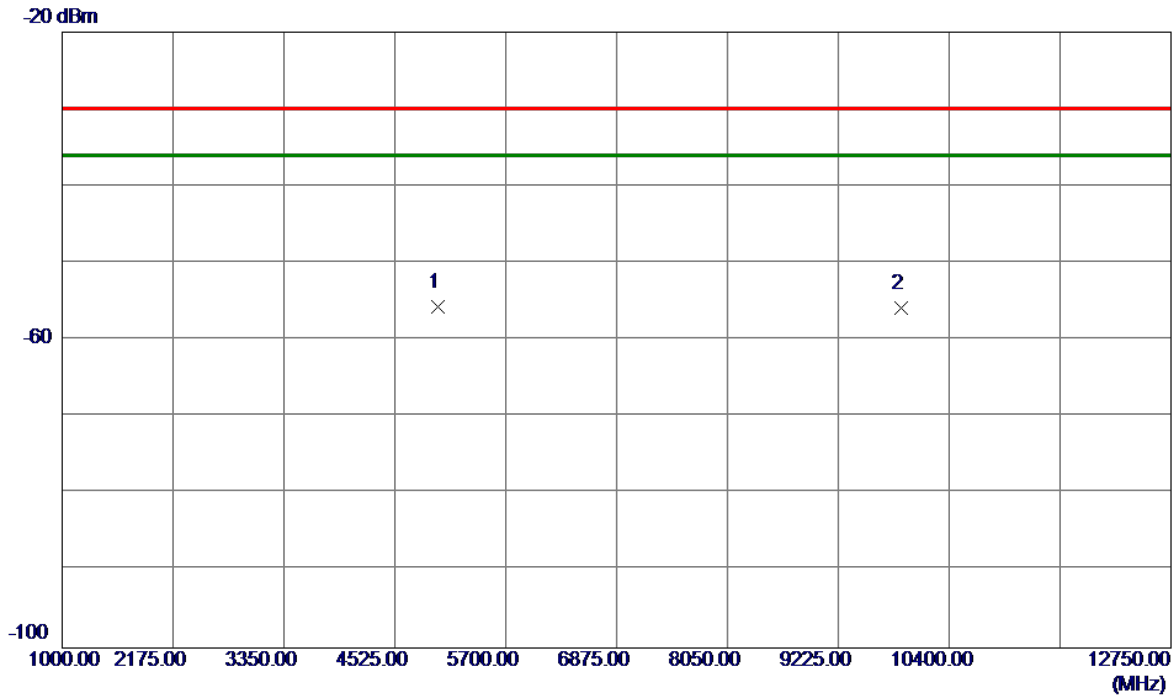

No.	Freq. MHz	Reading Level dBm	Correct Factor dB	Measure ment dBm	Limit dBm	Margin dB	Detector	Comment
1 *	4982.0750	-57.10	1.36	-55.74	-30.00	-25.74	RMS	
2	9887.7000	-62.71	6.81	-55.90	-30.00	-25.90	RMS	

Test Mode	TX Mode IEEE 802.11n(HT20)_2412 MHz	Polarization	Vertical
-----------	-------------------------------------	--------------	----------

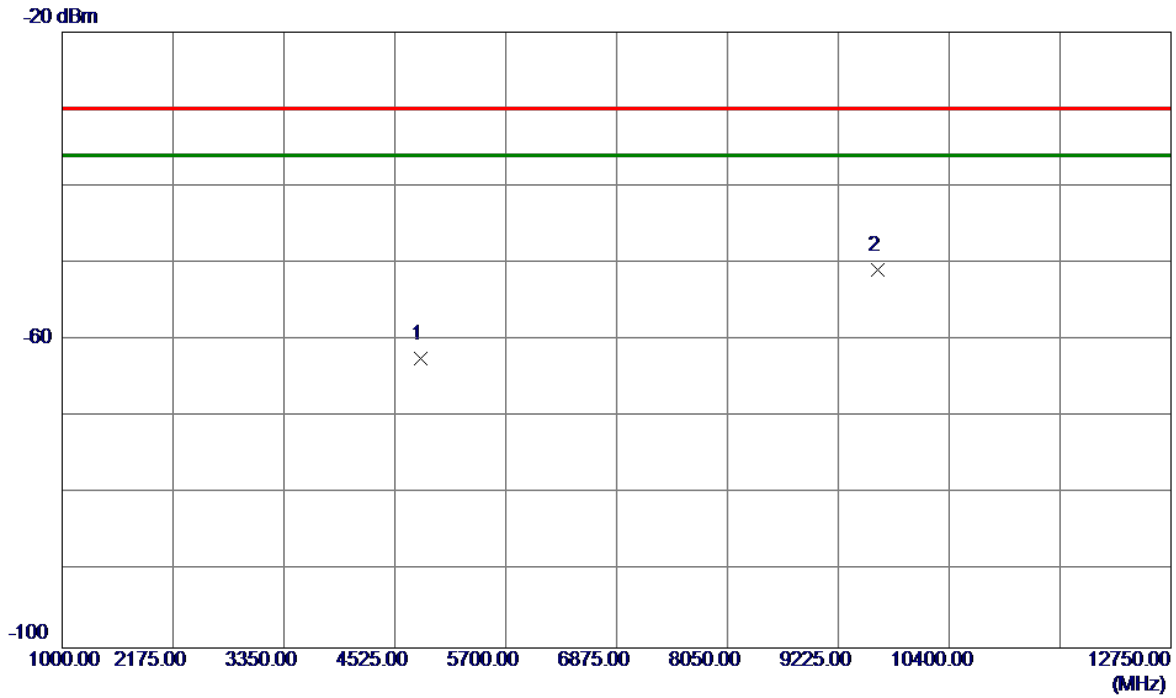

No.	Freq. MHz	Reading Level dBm	Correct Factor dB	Measure ment dBm	Limit dBm	Margin dB	Detector	Comment
1	4799.9500	-63.25	0.90	-62.35	-30.00	-32.35	RMS	
2 *	9648.0000	-56.91	6.08	-50.83	-30.00	-20.83	RMS	

Test Mode	TX Mode IEEE 802.11n(HT20)_2412 MHz	Polarization	Horizontal
-----------	-------------------------------------	--------------	------------

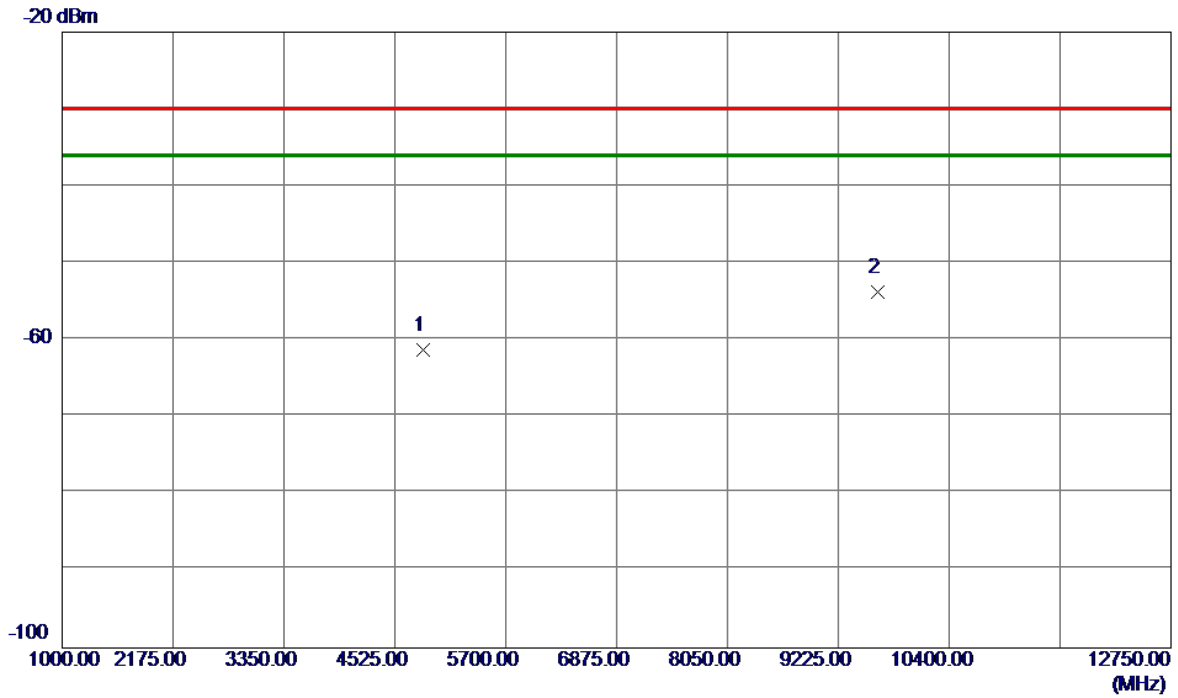

No.	Freq. MHz	Reading Level dBm	Correct Factor dB	Measure ment dBm	Limit dBm	Margin dB	Detector	Comment
1	4823.4500	-62.66	1.31	-61.35	-30.00	-31.35	RMS	
2 *	9648.0000	-60.04	6.29	-53.75	-30.00	-23.75	RMS	

Test Mode	TX Mode IEEE 802.11n(HT20)_2462 MHz	Polarization	Vertical
-----------	-------------------------------------	--------------	----------

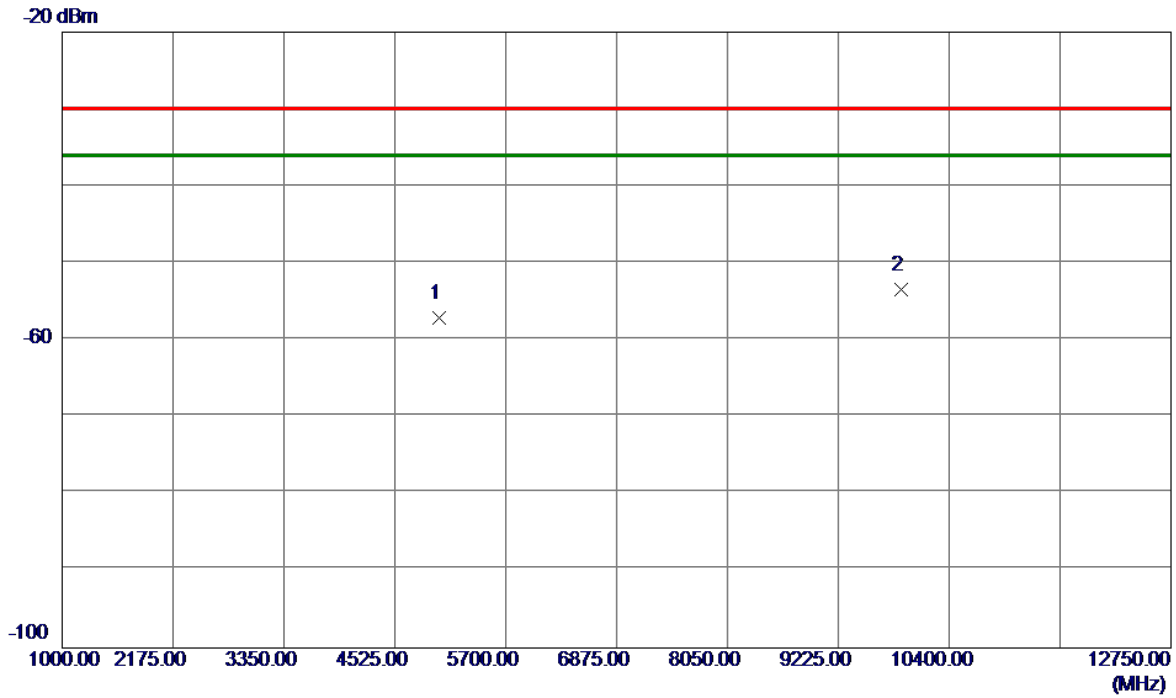

No.	Freq. MHz	Reading Level dBm	Correct Factor dB	Measure ment dBm	Limit dBm	Margin dB	Detector	Comment
1	4995.5870	-58.14	1.02	-57.12	-30.00	-27.12	RMS	
2 *	9887.7000	-60.07	6.58	-53.49	-30.00	-23.49	RMS	

Test Mode	TX Mode IEEE 802.11n(HT20)_2462 MHz	Polarization	Horizontal
-----------	-------------------------------------	--------------	------------

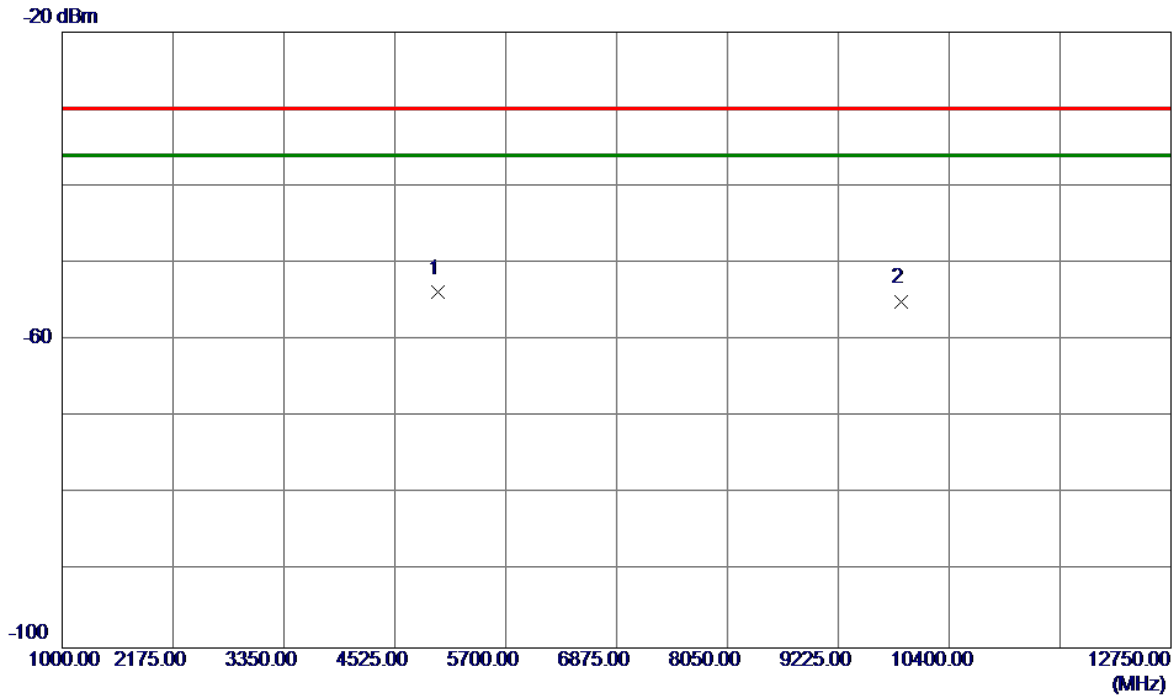

No.	Freq. MHz	Reading Level dBm	Correct Factor dB	Measure ment dBm	Limit dBm	Margin dB	Detector	Comment
1 *	4987.3630	-55.21	1.37	-53.84	-30.00	-23.84	RMS	
2	9887.7000	-61.84	6.81	-55.03	-30.00	-25.03	RMS	

Test Mode	TX Mode IEEE 802.11n(HT40)_2422 MHz	Polarization	Vertical
-----------	-------------------------------------	--------------	----------

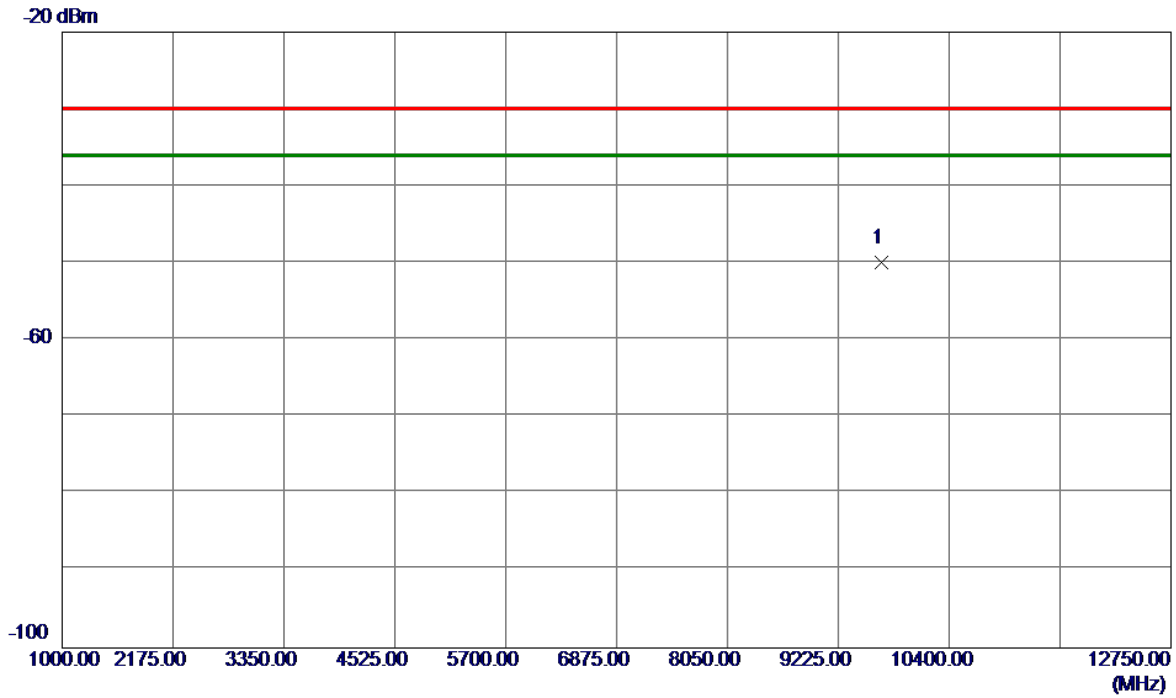

No.	Freq. MHz	Reading Level dBm	Correct Factor dB	Measure ment dBm	Limit dBm	Margin dB	Detector	Comment
1 *	9687.9500	-56.02	6.16	-49.86	-30.00	-19.86	RMS	

Test Mode	TX Mode IEEE 802.11n(HT40)_2422 MHz	Polarization	Horizontal
-----------	-------------------------------------	--------------	------------

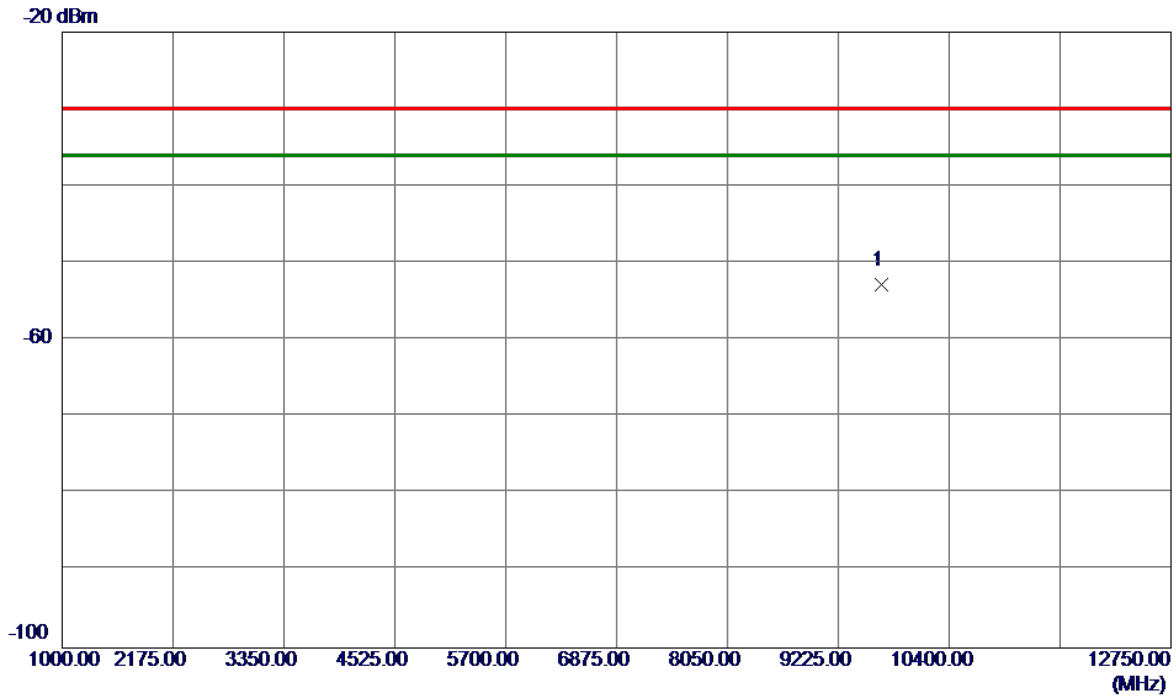

No.	Freq. MHz	Reading Level dBm	Correct Factor dB	Measure ment dBm	Limit dBm	Margin dB	Detector	Comment
1 *	9687.9500	-59.13	6.38	-52.75	-30.00	-22.75	RMS	

Test Mode	TX Mode IEEE 802.11n(HT40)_2452 MHz	Polarization	Vertical
-----------	-------------------------------------	--------------	----------

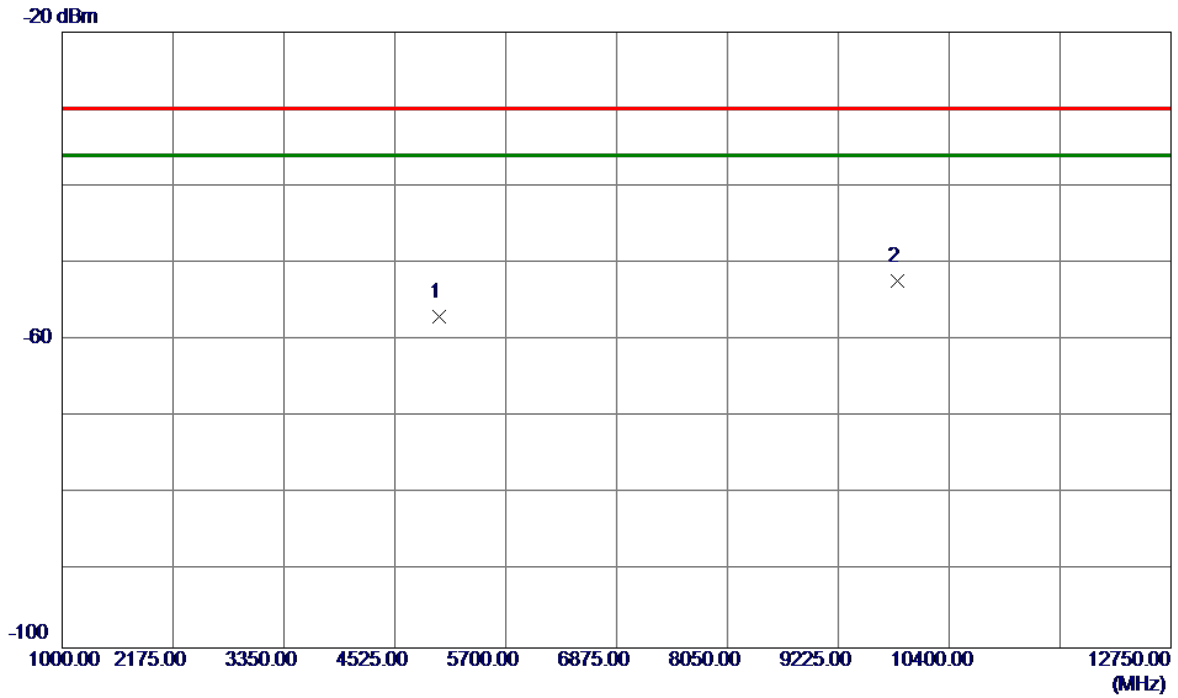

No.	Freq. MHz	Reading Level dBm	Correct Factor dB	Measure ment dBm	Limit dBm	Margin dB	Detector	Comment
1	4993.8250	-57.94	1.02	-56.92	-30.00	-26.92	RMS	
2 *	9847.7500	-58.77	6.49	-52.28	-30.00	-22.28	RMS	

Test Mode	TX Mode IEEE 802.11n(HT40)_2452 MHz	Polarization	Horizontal
-----------	-------------------------------------	--------------	------------

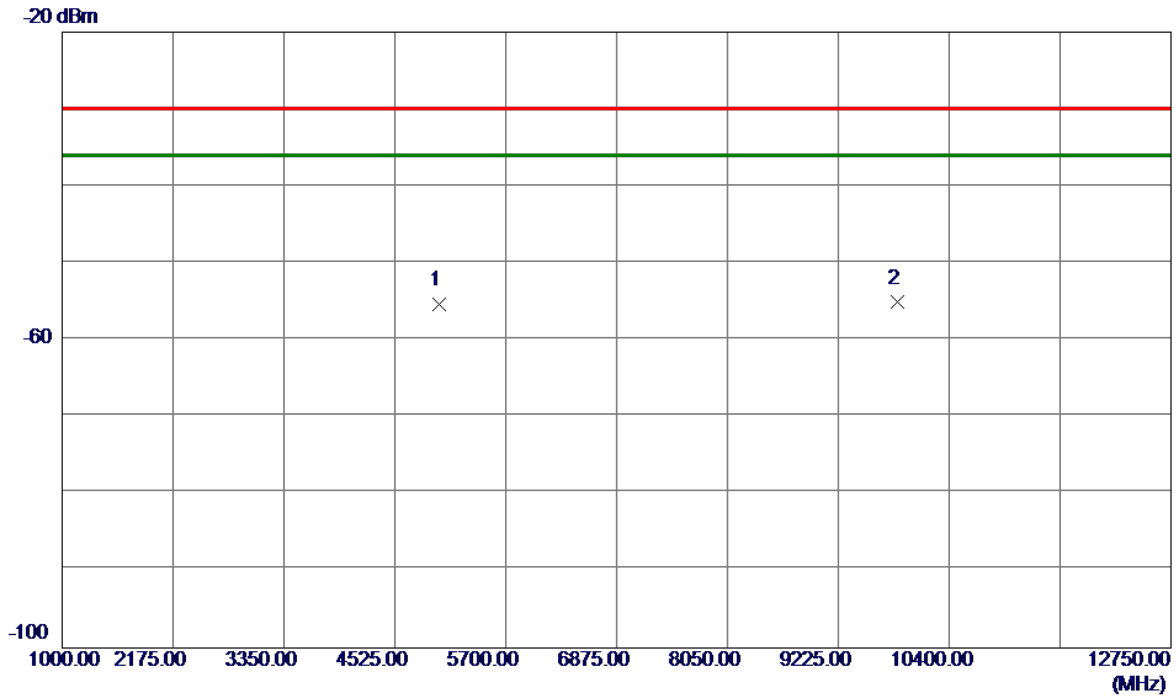

No.	Freq. MHz	Reading Level dBm	Correct Factor dB	Measure ment dBm	Limit dBm	Margin dB	Detector	Comment
1	4997.3500	-56.79	1.37	-55.42	-30.00	-25.42	RMS	
2 *	9847.7500	-61.84	6.72	-55.12	-30.00	-25.12	RMS	

APPENDIX I - RECEIVER SPURIOUS EMISSIONS

Test Mode	RX Mode IEEE 802.11g_2412 MHz	Polarization	Vertical
-----------	-------------------------------	--------------	----------

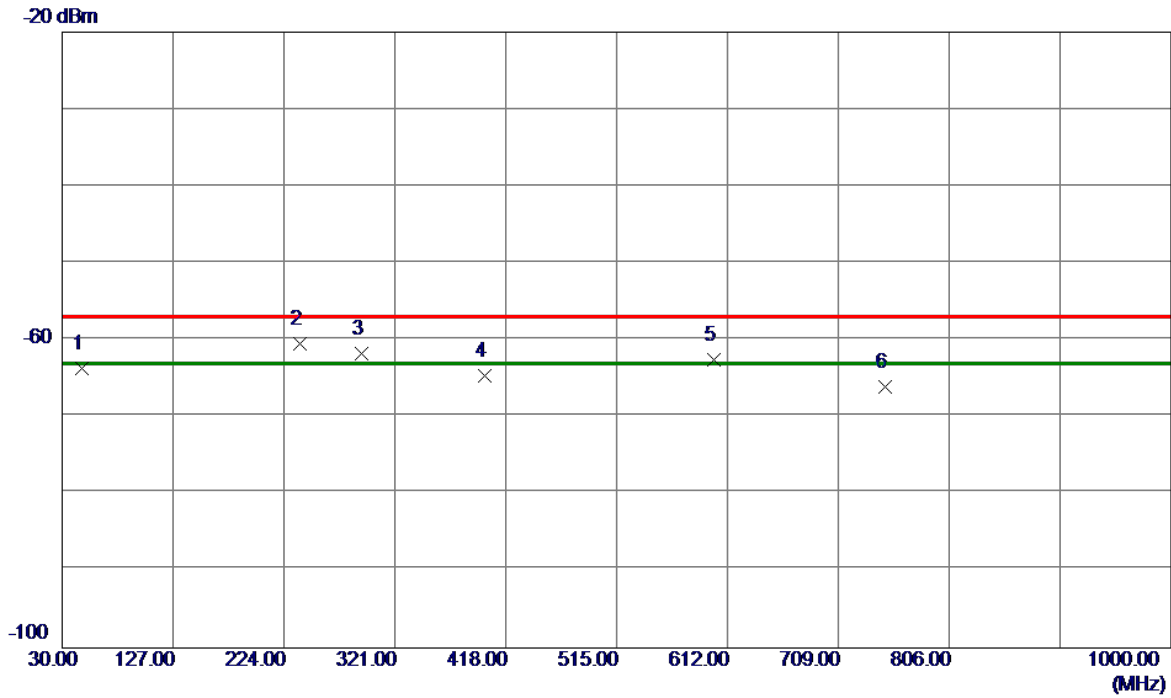

No.	Freq. MHz	Reading Level dBm	Correct Factor dB	Measure ment dBm	Limit dBm	Margin dB	Detector	Comment
1	47.4600	-64.00	0.27	-63.73	-57.00	-6.73	RMS	
2 *	237.9680	-58.50	-1.94	-60.44	-57.00	-3.44	RMS	
3	291.6090	-60.39	-1.38	-61.77	-57.00	-4.77	RMS	
4	399.9580	-65.65	0.99	-64.66	-57.00	-7.66	RMS	
5	599.9719	-67.43	4.94	-62.49	-57.00	-5.49	RMS	
6	749.9340	-72.79	6.75	-66.04	-57.00	-9.04	RMS	

Test Mode	RX Mode IEEE 802.11g_2412 MHz	Polarization	Horizontal
-----------	-------------------------------	--------------	------------

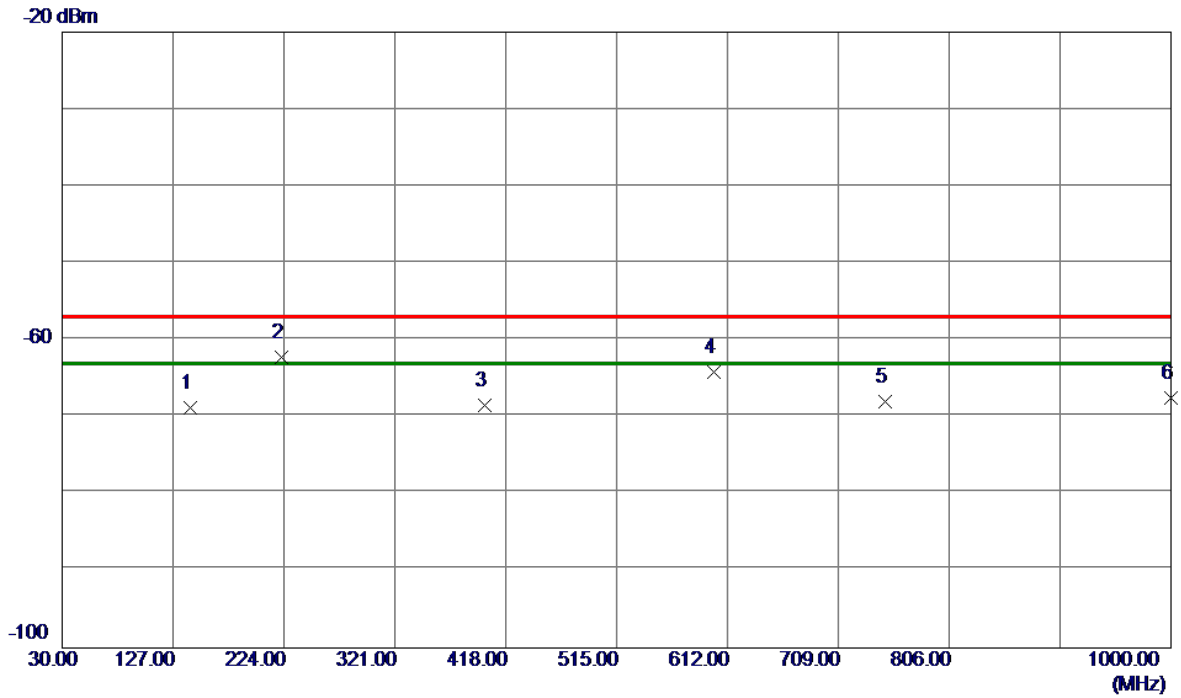

No.	Freq. MHz	Reading Level dBm	Correct Factor dB	Measure ment dBm	Limit dBm	Margin dB	Detector	Comment
1	142.5200	-69.68	0.88	-68.80	-57.00	-11.80	RMS	
2 *	221.6720	-60.02	-2.24	-62.26	-57.00	-5.26	RMS	
3	399.9580	-69.74	1.21	-68.53	-57.00	-11.53	RMS	
4	599.9719	-68.90	4.71	-64.19	-57.00	-7.19	RMS	
5	749.9340	-74.45	6.46	-67.99	-57.00	-10.99	RMS	
6	999.9030	-77.76	10.19	-67.57	-57.00	-10.57	RMS	

Test Mode	RX Mode IEEE 802.11g_2462 MHz	Polarization	Vertical
-----------	-------------------------------	--------------	----------

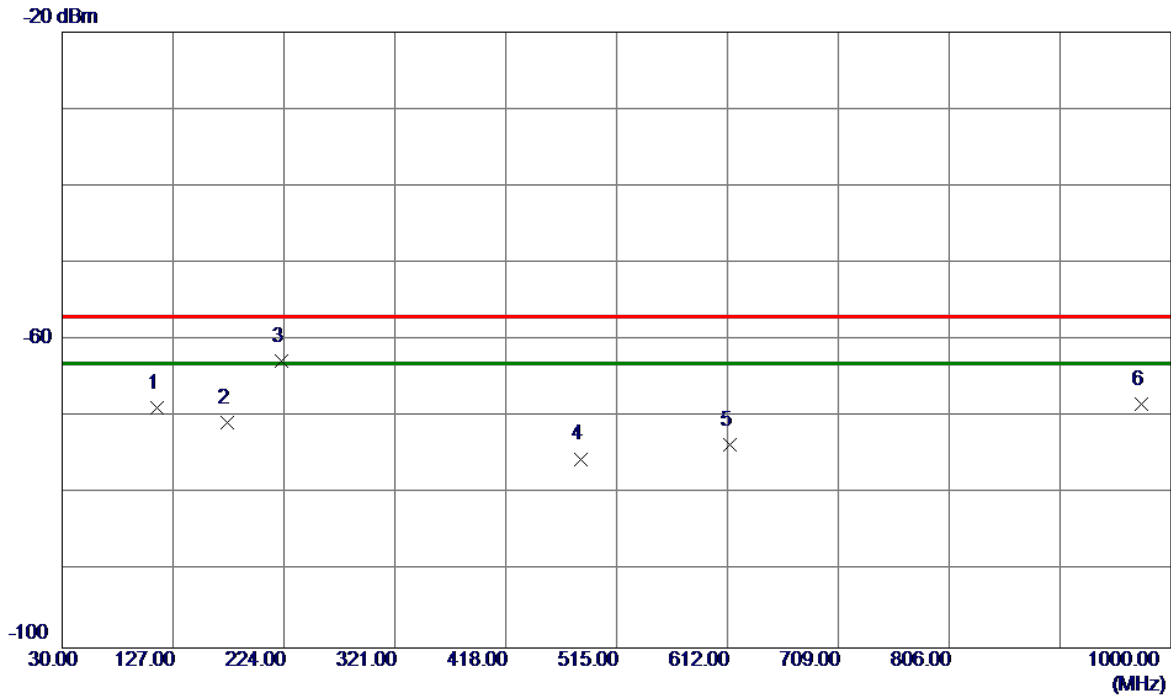

No.	Freq. MHz	Reading Level dBm	Correct Factor dB	Measure ment dBm	Limit dBm	Margin dB	Detector	Comment
1	112.6440	-65.29	-3.45	-68.74	-57.00	-11.74	RMS	
2	174.2390	-69.47	-1.22	-70.69	-57.00	-13.69	RMS	
3 *	221.7690	-59.85	-2.83	-62.68	-57.00	-5.68	RMS	
4	483.2810	-78.08	2.64	-75.44	-57.00	-18.44	RMS	
5	614.1340	-78.57	5.03	-73.54	-57.00	-16.54	RMS	
6	974.4890	-77.92	9.59	-68.33	-57.00	-11.33	RMS	

Test Mode	RX Mode IEEE 802.11g_2462 MHz	Polarization	Horizontal
-----------	-------------------------------	--------------	------------

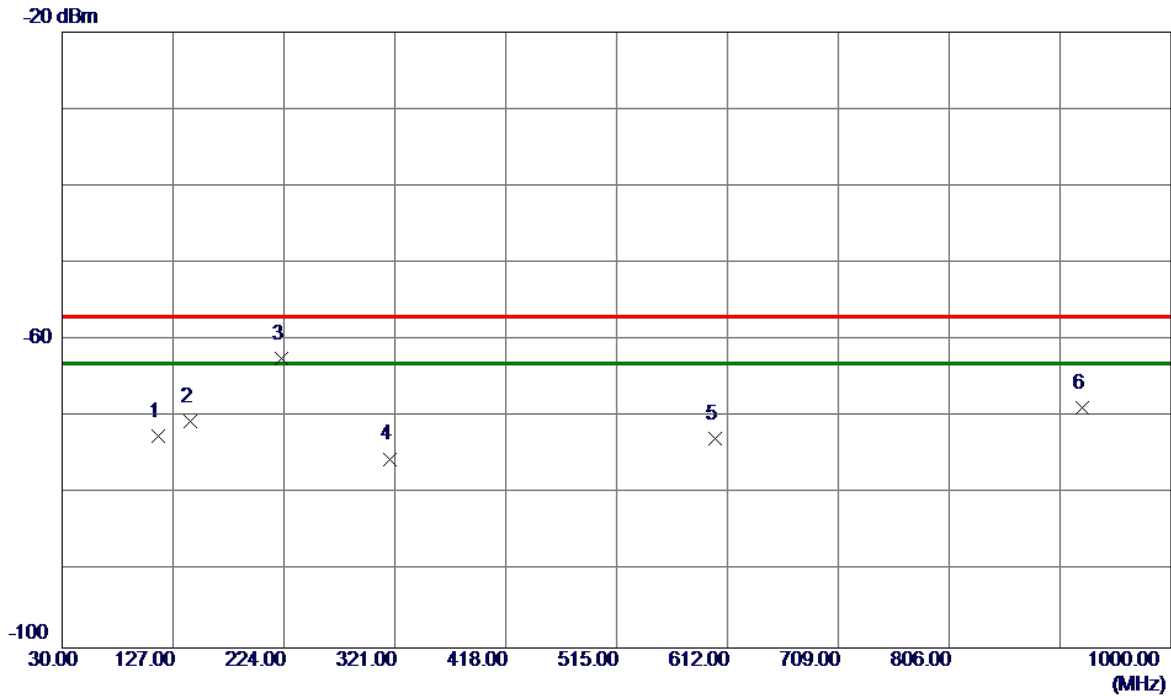

No.	Freq. MHz	Reading Level dBm	Correct Factor dB	Measure ment dBm	Limit dBm	Margin dB	Detector	Comment
1	113.8080	-68.61	-3.87	-72.48	-57.00	-15.48	RMS	
2	142.4230	-71.48	0.88	-70.60	-57.00	-13.60	RMS	
3 *	221.6720	-60.20	-2.24	-62.44	-57.00	-5.44	RMS	
4	316.6350	-74.87	-0.57	-75.44	-57.00	-18.44	RMS	
5	601.3300	-77.47	4.73	-72.74	-57.00	-15.74	RMS	
6	922.5940	-77.61	8.76	-68.85	-57.00	-11.85	RMS	

Test Mode	RX Mode IEEE 802.11g_2412 MHz	Polarization	Vertical
-----------	-------------------------------	--------------	----------

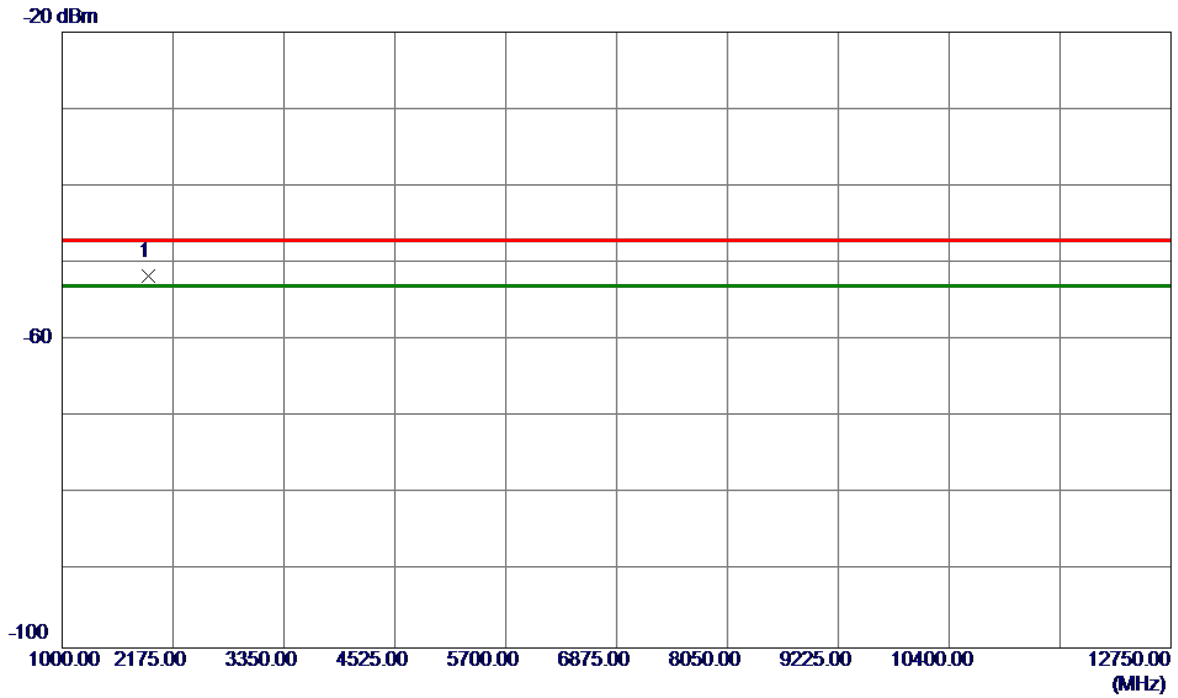

No.	Freq. MHz	Reading Level dBm	Correct Factor dB	Measure ment dBm	Limit dBm	Margin dB	Detector	Comment
1 *	1909.4500	-47.10	-4.51	-51.61	-47.00	-4.61	RMS	

Test Mode	RX Mode IEEE 802.11g_2412 MHz	Polarization	Horizontal
-----------	-------------------------------	--------------	------------

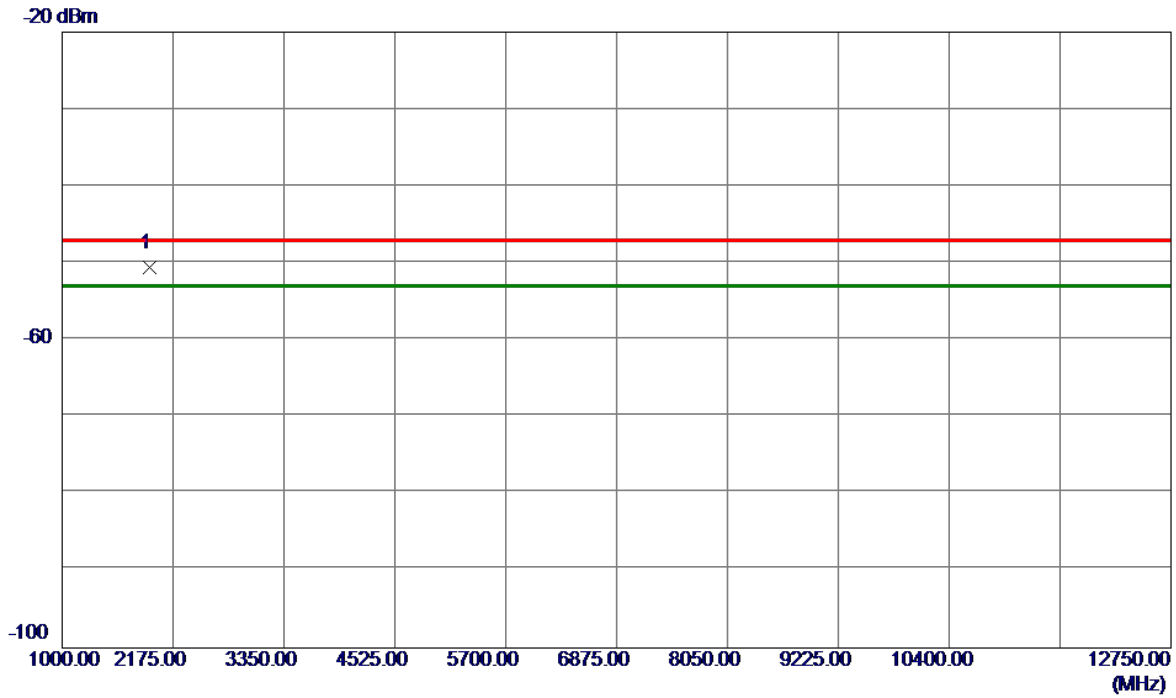

No.	Freq. MHz	Reading Level dBm	Correct Factor dB	Measure ment dBm	Limit dBm	Margin dB	Detector	Comment
1 *	1926.4870	-46.89	-3.71	-50.60	-47.00	-3.60	RMS	

Test Mode	RX Mode IEEE 802.11g_2462 MHz	Polarization	Vertical
-----------	-------------------------------	--------------	----------

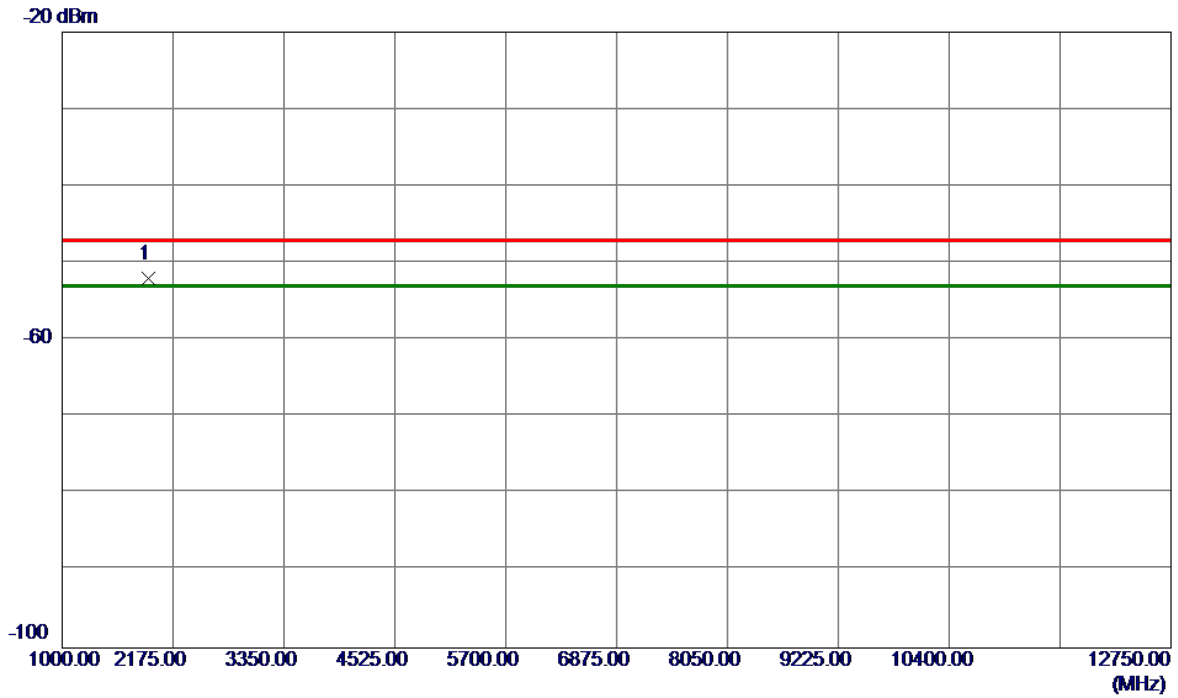

No.	Freq. MHz	Reading Level dBm	Correct Factor dB	Measure ment dBm	Limit dBm	Margin dB	Detector	Comment
1 *	1907.6880	-47.51	-4.53	-52.04	-47.00	-5.04	RMS	

Test Mode	RX Mode IEEE 802.11g_2462 MHz	Polarization	Horizontal
-----------	-------------------------------	--------------	------------

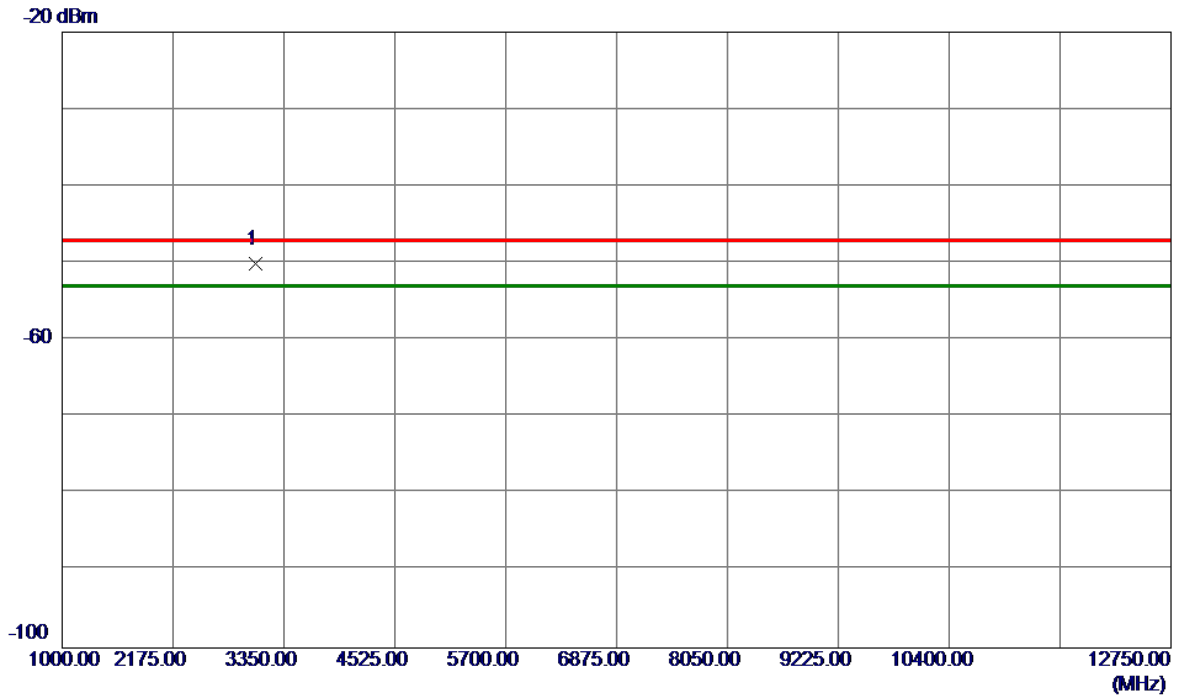

No.	Freq. MHz	Reading Level dBm	Correct Factor dB	Measure ment dBm	Limit dBm	Margin dB	Detector	Comment
1 *	3055.0750	-50.54	0.48	-50.06	-47.00	-3.06	RMS	

APPENDIX J - RECEIVER BLOCKING

Receiver Blocking Result						
Modulation Mode	Operation Freq. (MHz)	Wanted Signal Mean Power from Companion Device (dBm) (See Note 1)	Blocking Signal Freq. (MHz) (See Note 2)	Blocking Signal Power (dBm) (See Note 1)	Blocking Signal Power + Max. Ant. Gain (dBm)	PER (%)
802.11b Mode	2412	-63.85	2380	-34	-29.85	0.00
		-69.85	2300	-34	-29.85	0.20
			2330	-34	-29.85	0.00
			2360	-34	-29.85	0.00
	2462	-63.85	2504	-34	-29.85	0.40
		-69.85	2524	-34	-29.85	0.00
			2584	-34	-29.85	0.00
			2674	-34	-29.85	0.00
Limit	PER(Packet Error Rate) ≤ 10%					
Result	Pass					

Note:

- 1) The levels had been corrected by the actual antenna assembly gain.
- 2) The test report did not use the shift of blocking frequencies with the standard Clause 5.4.11.2.1 Step 5.

**APPENDIX K - INFORMATION AS REQUIRED BY
EN 300 328 V2.2.2, CLAUSE 5.4.1**

In accordance with ETSI EN 300 328, clause 5.4.1, the following information is provided by the manufacturer.

a) The type of wideband data transmission equipment:

- FHSS
 non-FHSS

b) In case of FHSS:

(1) In case of non-Adaptive FHSS equipment:

The number of Hopping Frequencies: N/A

(2) In case of Adaptive FHSS equipment:

The maximum number of Hopping Frequencies: N/A

The minimum number of Hopping Frequencies: N/A

(3) The (average) dwell time: N/A

c) Adaptive / non-adaptive equipment:

- non-adaptive Equipment
 adaptive Equipment without the possibility to switch to a non-adaptive mode
 adaptive Equipment which can also operate in a non-adaptive mode

d) In case of adaptive equipment:

The maximum Channel Occupancy Time implemented by the equipment: 5.44 ms

The equipment has implemented an LBT mechanism

* In case of non-FHSS equipment:

- The equipment is Frame Based equipment
 The equipment is Load Based equipment
 The equipment can switch dynamically between Frame Based and Load Based

equipment

The CCA time implemented by the equipment: 159 μ s

- The equipment has implemented a DAA mechanism
 The equipment can operate in more than one adaptive mode

f) The worst case operational mode for each of the following tests:

- (1) RF Output Power: 19.80 dBm
- (2) Power Spectral Density: 9.98 dBm/MHz
- (3) Duty cycle, Tx-Sequence, Tx-gap: N/A
- (4) Accumulated Transmit time, Frequency Occupation & Hopping Sequence (only for FHSS equipment): N/A
- (5) Hopping Frequency Separation (only for FHSS equipment): N/A
- (6) Medium Utilization: N/A
- (7) Adaptivity: 3.0 ms, Receiver Blocking: 0.40 %
- (8) Nominal Channel Bandwidth: 40 MHz
- (9) Transmitter unwanted emissions in the OOB domain: -26.84 dBm
- (10) Transmitter unwanted emissions in the spurious domain: -61.42 dBm
- (11) Receiver spurious emissions: -50.06 dBm

g) The different transmit operating modes (tick all that apply):

- Operating mode 1: Single Antenna Equipment
 - Equipment with only one antenna
 - Equipment with two diversity antennas but only one antenna active at any moment in time
 - Smart Antenna Systems with two or more antennas, but operating in a (legacy) mode where only one antenna is used. (e.g. IEEE 802.11™ legacy mode in smart antenna systems)

- Operating mode 2: Smart Antenna Systems - Multiple Antennas without beam forming
 - Single spatial stream / Standard throughput (e.g. IEEE 802.11™ legacy mode)
 - High Throughput (> 1 spatial stream) using Nominal Channel Bandwidth 1
 - High Throughput (> 1 spatial stream) using Nominal Channel Bandwidth 2

NOTE 1: Add more lines if more channel bandwidths are supported.

- Operating mode 3: Smart Antenna Systems - Multiple Antennas with beam forming
 - Single spatial stream / Standard throughput (e.g. IEEE 802.11™ legacy mode)
 - High Throughput (> 1 spatial stream) using Nominal Channel Bandwidth 1
 - High Throughput (> 1 spatial stream) using Nominal Channel Bandwidth 2

NOTE 2: Add more lines if more channel bandwidths are supported.

h) In case of Smart Antenna Systems:(1) The number of Receive chains: 2 (2) The number of Transmit chains: 2 symmetrical power distribution asymmetrical power distributionIn case of beam forming, the maximum (additional) beam forming gain: N/A dB

NOTE: The additional beam forming gain does not include the basic gain of a single antenna.

i) Operating Frequency Range(s) of the equipment:(1) Operating Frequency Range 1: 2412 MHz to 2462 MHz

NOTE: Add more lines if more Frequency Ranges are supported.

j) Nominal Channel Bandwidth(s):(1) Nominal Channel Bandwidth 1: 20 MHz(2) Nominal Channel Bandwidth 2: 40 MHz

NOTE: Add more lines if more channel bandwidths are supported.

k) Type of Equipment (stand-alone, combined, plug-in radio device, etc.): Stand-alone Combined Equipment Plug-in radio device Other _____**l) The extreme operating conditions that apply to the equipment:**Operating temperature range: 0 ° C to 40 ° CDetails provided are for the: stand-alone equipment combined equipment test jig

n) The nominal voltages of the stand-alone radio equipment or the nominal voltages of the combined equipment or test jig in case of plug-in devices:

Details provided are for the: stand-alone equipment

combined equipment

test jig

Supply Voltage AC mains State AC voltage ____ V

DC State DC voltage 12 V

In case of DC, indicate the type of power source

Internal Power Supply

External Power Supply or AC/DC adapter

Battery

Other: _____

o) Describe the test modes available which can facilitate testing:

The measurements shall be performed during continuously transmitting and normal operation.

p) The equipment type (e.g. Bluetooth®, IEEE 802.11™, IEEE 802.15.4™, proprietary, etc.):

IEEE 802.11™

s) Geo-location capability supported by the equipment:

Yes

The geographical location determined by the equipment as defined in clause 4.3.1.13.2 or clause 4.3.2.12.2 is not accessible to the user

No

End of Test Report