



CE Radio Test Report

Project No. : 2405G097
Equipment : Projector
Brand Name : XGIMI
Test Model : XN13A
Series Model : N/A
Applicant : XGIMI Technology Co., Ltd.
Address : Building No.4, Zone A, No.1129, Shijicheng Road, Chengdu High-tech Zone, Sichuan Pilot Free Trade Zone, China
Manufacturer : XGIMI Technology Co., Ltd.
Address : Building No.4, Zone A, No.1129, Shijicheng Road, Chengdu High-tech Zone, Sichuan Pilot Free Trade Zone, China
Factory : Yibin XGIMI Optoelectronic Co., Ltd.
Address : No. 2, West Section 4, Changjiang North Road, Lingang Economic Development Zone, Yibin City, Sichuan P.R. China
Date of Receipt : May 31, 2024
Date of Test : Jun. 06, 2024 ~ Jul. 11, 2024
Issued Date : Jul. 19, 2024
Report Version : R00
Test Sample : Engineering Sample No.: SSL2024053139 for radiated, SSL2024053135 for blocking and adjacent channel selectivity, SSL2024053136 for others.
Standard(s) : ETSI EN 300 440 V2.2.1 (2018-07)

The above equipment has been tested and found compliance with the requirement of the relative standards by BTL Inc.

Prepared by : Sheldon Ou
Sheldon Ou

Approved by : Chay Cai
Chay Cai

Room 108, Building 2, No.1, Yile Road, Songshan Lake Zone, Dongguan City, Guangdong, People's Republic of China.

Tel: +86-769-8318-3000 Web: www.newbtl.com Service mail: btl_qa@newbtl.com

Declaration

BTL represents to the client that testing is done in accordance with standard procedures as applicable and that test instruments used has been calibrated with standards traceable to international standard(s) and/or national standard(s).

BTL's reports apply only to the specific samples tested under conditions. It is manufacture's responsibility to ensure that additional production units of this model are manufactured with the identical electrical and mechanical components. **BTL** assumes no responsibility for the data provided by the customer, any statements, inferences or generalizations drawn by the customer or others from the reports issued by **BTL**.

The report must not be used by the client to claim product certification, approval, or endorsement by A2LA or any agency of the U.S. Government.

This report is the confidential property of the client. As a mutual protection to the clients, the public and ourselves, the test report shall not be reproduced, except in full, without our written approval.

BTL's laboratory quality assurance procedures are in compliance with the ISO/IEC 17025: 2017 requirements, and accredited by the conformity assessment authorities listed in this test report.

BTL is not responsible for the sampling stage, so the results only apply to the sample as received.

The information, data and test plan are provided by manufacturer which may affect the validity of results, so it is manufacturer's responsibility to ensure that the apparatus meets the essential requirements of applied standards and in all the possible configurations as representative of its intended use.

Limitation

For the use of the authority's logo is limited unless the Test Standard(s)/Scope(s)/Item(s) mentioned in this test report is (are) included in the conformity assessment authorities acceptance respective.

Please note that the measurement uncertainty is provided for informational purpose only and are not use in determining the Pass/Fail results.

Table of Contents**Page**

REPORT ISSUED HISTORY	6
1 . RF EMISSIONS MEASUREMENT	7
1.1 TEST FACILITY	7
1.2 MEASUREMENT UNCERTAINTY	7
1.3 TEST CONDITIONS	7
1.4 TEST CHANNEL	9
1.5 TEST METHODOLOGY AND RESULTS	10
2 . GENERAL INFORMATION	11
2.1 GENERAL DESCRIPTION OF EUT	11
2.2 DESCRIPTION OF TEST MODES	13
2.3 TABLE OF PARAMETERS OF TEST SOFTWARE SETTING	14
2.4 BLOCK DIAGRAM SHOWING THE CONFIGURATION OF SYSTEM TESTED	15
2.5 DESCRIPTION OF SUPPORT UNITS	15
2.6 CUSTOMER INFORMATION DESCRIPTION	15
3 . EQUIVALENT ISOTROPICALLY RADIATED POWER (E.I.R.P.)	16
3.1 LIMITS	16
3.2 TEST PROCEDURES	16
3.3 TEST SETUP LAYOUT	16
3.4 TEST DEVIATION	17
3.5 EUT OPERATION DURING TEST	17
3.6 TEST RESULTS	17
4 . PERMITTED RANGE OF OPERATING FREQUENCIES	18
4.1 LIMITS	18
4.2 TEST PROCEDURES	18
4.3 TEST SETUP LAYOUT	18
4.4 TEST DEVIATION	18
4.5 EUT OPERATION DURING TEST	18
4.6 TEST RESULTS	18
5 . UNWANTED EMISSIONS IN THE SPURIOUS DOMAIN	19
5.1 LIMITS	19
5.2 TEST PROCEDURES	19
5.3 TEST SETUP LAYOUT	19
5.4 TEST DEVIATION	20
5.5 EUT OPERATION DURING TEST	20
5.6 TEST RESULTS (25MHZ TO 1000MHZ)	20
5.7 TEST RESULTS (ABOVE 1000MHZ)	20
6 . DUTY CYCLE	21
6.1 LIMITS	21
6.2 TEST PROCEDURES	21
6.3 TEST SETUP LAYOUT	21

Table of Contents	Page
6.4 TEST DEVIATION	21
6.5 EUT OPERATION DURING TEST	21
6.6 TEST RESULTS	21
7 . ADJACENT CHANNEL SELECTIVITY	22
7.1 LIMITS	22
7.2 TEST PROCEDURES	22
7.3 TEST SETUP LAYOUT	22
7.4 TEST DEVIATION	22
7.5 EUT OPERATION DURING TEST	22
7.6 TEST RESULTS	22
8 . BLOCKING OR DESENSITIZATION	23
8.1 LIMITS	23
8.2 TEST PROCEDURES	23
8.3 TEST SETUP LAYOUT	23
8.4 TEST DEVIATION	23
8.5 EUT OPERATION DURING TEST	23
8.6 TEST RESULTS	23
9 . SPURIOUS RADIATIONS	24
9.1 LIMITS	24
9.2 TEST PROCEDURES	24
9.3 TEST SETUP LAYOUT	24
9.4 TEST DEVIATION	24
9.5 EUT OPERATION DURING TEST	24
9.6 TEST RESULTS (25MHZ TO 1000MHZ)	24
9.7 TEST RESULTS (ABOVE 1000MHZ)	24
10 . MEASUREMENT INSTRUMENTS LIST	25
11 . EUT TEST PHOTO	28
APPENDIX A - EQUIVALENT ISOTROPICALLY RADIATED POWER	30
APPENDIX B - PERMITTED RANGE OF OPERATING FREQUENCIES	33
APPENDIX C - UNWANTED EMISSIONS IN THE SPURIOUS DOMAIN - OPERATING (25MHZ TO 1000MHZ)	38
APPENDIX D - UNWANTED EMISSIONS IN THE SPURIOUS DOMAIN - STANDBY (25MHZ TO 1000MHZ)	43
APPENDIX E - UNWANTED EMISSIONS IN THE SPURIOUS DOMAIN - OPERATING (ABOVE 1000MHZ)	44
APPENDIX F - UNWANTED EMISSIONS IN THE SPURIOUS DOMAIN - STANDBY (ABOVE 1000MHZ)	61
APPENDIX G - DUTY CYCLE	62

Table of Contents**Page**

APPENDIX H - ADJACENT CHANNEL SELECTIVITY	64
APPENDIX I - BLOCKING	66
APPENDIX J - SPURIOUS EMISSIONS - RECEIVER (25MHZ TO 1000MHZ)	68
APPENDIX K - SPURIOUS EMISSIONS - RECEIVER (ABOVE 1000MHZ)	73

REPORT ISSUED HISTORY

Report No.	Version	Description	Issued Date	Note
BTL-ETSP-6-2405G097	R00	Original Report.	Jul. 19, 2024	Valid

1. RF EMISSIONS MEASUREMENT

1.1 TEST FACILITY

The test facilities used to collect the test data in this report is **DG-CB15 / TR13 / TR15 / TR17** at the location of No.3, Jinshagang 1st Road, Dalang, Dongguan City, Guangdong People's Republic of China.

1.2 MEASUREMENT UNCERTAINTY

The measurement uncertainty figures shall be calculated according the methods described in the ETSI TR 100 028 and shall correspond to an expansion factor (coverage factor) $k=1.96$ or $k=2$ (which provide confidence levels of respectively 95% and 95.45% in the case where the distributions characterizing the actual measurement uncertainties are normal (Gaussian)).

Measurement Uncertainty for a Level of Confidence of 95.45%, $U=2 \times u_c(y)$.

The BTL measurement uncertainty as below table:

Parameters	Uncertainty
Radio frequency	2.7 ppm
RF power (conducted)	1.3 dB
Radiated emission of transmitter/receiver (25MHz ~ 1GHz)	3.50 dB
Radiated emission of transmitter/receiver (1GHz ~ 18GHz)	3.54 dB
Radiated emission of transmitter/receiver (18GHz ~ 40GHz)	4.00 dB
Temperature	0.8 °C
Humidity	2.2 %
Voltage (DC)	1 %
Voltage (AC, < 10 kHz)	2 %

1.3 TEST CONDITIONS

	Normal Test Conditions	Extreme Test Conditions
Temperature	+15°C to +35°C	0°C to +40°C
Relative Humidity	20% to 75%	N/A
Supply Voltage	DC 12V	DC 10.8-13.2V Note: (2)

Test Item	Temperature	Humidity	Test Voltage	Tested By	Test Date
Equivalent isotropically radiated power (e.i.r.p.)	Normal & Extreme	52%	Normal & Extreme	Alex Yin	Jun. 24, 2024
Permitted range of operating frequencies	Normal & Extreme	48-51%	Normal & Extreme	Arvin Tong	Jul. 04, 2024- Jul. 08, 2024
Unwanted emissions in the spurious domain	22-25°C	42-45%	AC 230V/50Hz	Meers Zhang	Jul. 01, 2024- Jul. 03, 2024
Duty cycle	26°C	48%	DC 12V	Arvin Tong	Jul. 04, 2024
Adjacent channel selectivity	23°C	52%	DC 12V	Complex Qin	Jul. 04, 2024
Blocking or desensitization	23°C	52%	DC 12V	Complex Qin	Jul. 04, 2024
Spurious radiations	22-25°C	42-45%	AC 230V/50Hz	Meers Zhang	Jul. 01, 2024- Jul. 03, 2024

Note:

- (1) For tests at extreme temperatures, measurements shall be made in accordance with the procedures specified in clause 5.7.1.1, at the upper and lower temperatures of one of the following ranges, either:

The temperature range as declared by the manufacturer	0°C to +40°C	√
Category I (General):	-20°C to +55°C	
Category II (Portable):	-10°C to +55°C	
Category III (Equipment for normal indoor use):	5°C to +35°C	

(2) **Mains voltage:**

- 1) The normal test voltage for equipment to be connected to the mains shall be the nominal mains voltage. For the purpose of the present document, the nominal voltage shall be the declared voltage, or any of the declared voltages, for which the equipment was designed.
- 2) The extreme test voltages for equipment to be connected to an ac mains source shall be the nominal mains voltage $\pm 10\%$. For equipment that operates over a range of mains voltages clause 5.7.2.4 applies.

Battery power sources

- 1) When the radio equipment is intended for operation with the usual types of battery power source, the normal test voltage shall be 1,1 multiplied by the nominal voltage of the battery (e.g. 6 V, 12 V, etc.).
- 2) When the radio equipment is intended for operation from the usual type of battery power sources the extreme test voltages shall be 1,3 and 0,9 multiplied by the nominal voltage of the battery (6 V, 12 V, etc.).

For float charge applications using "gel-cell" type batteries the extreme voltage shall be 1,15 and 0,85 multiplied by the nominal voltage of the declared battery voltage.

Power sources using other types of batteries

The lower extreme test voltages for equipment with power sources using batteries shall be as follows:

- for equipment with a battery indicator, the end point voltage as indicated;
- for equipment without a battery indicator the following end point voltages shall be used:
 - for the Leclanché or the lithium type of battery:
 - 0,85 multiplied by the nominal voltage of the battery;
 - for the nickel-cadmium type of battery:
 - 0,9 multiplied by the nominal voltage of the battery;
- for other types of battery or equipment, the lower extreme test voltage for the discharged condition shall be declared by the equipment manufacturer.

The nominal voltage is considered to be the upper extreme test voltage in this case.

Other power sources

- 1) For operation from other power sources or types of battery (primary or secondary), the normal test voltage shall be that declared by the equipment manufacturer and agreed to by the accredited test laboratory. Such values shall be stated in the test report.
- 2) For equipment using other power sources, or capable of being operated from a variety of power sources, the extreme test voltages shall be those agreed between the equipment manufacturer and the test laboratory. This shall be recorded in the test report.

1.4 TEST CHANNEL

IEEE 802.11a / IEEE 802.11n(HT20) / IEEE 802.11ac(VHT20)		
Test Channel	EUT Channel	Test Frequency
Low	CH149	5745 MHz
Middle	CH157	5785 MHz
High	CH165	5825 MHz

IEEE 802.11n(HT40) / IEEE 802.11ac(VHT40)		
Test Channel	EUT Channel	Test Frequency
Low	CH151	5755 MHz
High	CH159	5795 MHz

IEEE 802.11ac(VHT80)		
Test Channel	EUT Channel	Test Frequency
High	CH155	5775 MHz

1.5 TEST METHODOLOGY AND RESULTS

Harmonised Standard ETSI EN 300 440					
Requirement			Requirement Conditionality		Observations
No	Description	Reference: Clause No	U/C	Condition	
1	e.i.r.p.	4.2.2	C	Applies to all devices with transmitters	PASS
2	Permitted range of operating frequencies	4.2.3	C	Applies to all devices with transmitters	PASS
3	Unwanted emissions in the spurious domain	4.2.4	C	Applies to all devices with transmitters	PASS Note (2)
4	Duty cycle	4.2.5.4	C	Transmitting devices which do not use LBT, DAA, or RFID transmitters operating in the 2 446 to 2 454 MHz band transmitting more than 500 mW e.i.r.p. power level	PASS
5	Additional requirements for FHSS equipment	4.2.6	C	Equipment utilizing FHSS modulation	N/A
6	Adjacent channel selectivity	4.3.3	C	Applies to equipment Category 1 receivers	PASS
7	Blocking or desensitization	4.3.4	C	Applies to category 1, 2, and 3 SRD communication media receivers	PASS
8	Spurious radiations	4.3.5	C	Applies to all receivers, except receivers used in combination with permanently co-located transmitters continuously transmitting	PASS
9	Spectrum access techniques	4.4	C	Equipment which are not using duty cycle restrictions for media access	N/A
10	GBSAR antenna pattern	4.6.4	C	Applies only GBSAR systems	N/A
11	Limits for GBSAR	Annex I	C	Applies only GBSAR systems	N/A

Note:

(1) "U/C": Indicates whether the requirement is unconditionally applicable (U) or is conditional upon the manufacturer's claimed functionality of the equipment (C).

"N/A": indicates test is not applicable to this device.

(2) The emission of the transmitter on standby mode is equal to that of receiving mode.

2. GENERAL INFORMATION

2.1 GENERAL DESCRIPTION OF EUT

Equipment	Projector
Brand Name	XGIMI
Test Model	XN13A
Series Model	N/A
Model Difference(s)	N/A
Hardware Version	V06
Software Version	V0.0.75
Power Source	DC voltage supplied from AC adapter. Model: S065ARV2000325
Power Rating	I/P: 100-240V~ 50/60Hz 1.8A Max O/P: 5.0V===3.0A 15.0W or 9.0V===3.0A 27.0W or 12.0V===3.0A 36.0W or 15.0V===3.0A 45.0W or 20.0V===3.25A 65.0W
Operation Frequency	5725 MHz ~ 5850 MHz
Modulation Type	IEEE 802.11a/n/ac: OFDM
Bit Rate of Transmitter	IEEE 802.11a: 54/48/36/24/18/12/9/6 Mbps IEEE 802.11n: up to 300 Mbps IEEE 802.11ac: up to 866.7 Mbps
Max. e.i.r.p.	IEEE 802.11a: 13.81 dBm (24.04 mW) IEEE 802.11n(HT20): 13.89 dBm (24.49 mW) IEEE 802.11n(HT40): 13.32 dBm (21.48 mW) IEEE 802.11ac(VHT20): 13.95 dBm (24.83 mW) IEEE 802.11ac(VHT40): 13.76 dBm (23.77 mW) IEEE 802.11ac(VHT80): 13.94 dBm (24.77 mW)
Categorization	<input checked="" type="checkbox"/> Receiver category 1 <input type="checkbox"/> Receiver category 2 <input type="checkbox"/> Receiver category 3

Note:

- For a more detailed features description, please refer to the manufacturer's specifications or the user's manual.

2. Channel List:

IEEE 802.11a IEEE 802.11n(HT20) IEEE 802.11ac(VHT20)		IEEE 802.11n(HT40) IEEE 802.11ac(VHT40)		IEEE 802.11ac(VHT80)	
Band 4		Band 4		Band 4	
Channel	Frequency (MHz)	Channel	Frequency (MHz)	Channel	Frequency (MHz)
149	5745	151	5755	155	5775
153	5765	159	5795		
157	5785				
161	5805				
165	5825				

3. Table for Filed Antenna:

Ant.	Brand	Model Name	Antenna Type	Connector	Gain (dBi)
1	ZTX	N/A	FPC	N/A	4.30
2	ZTX	N/A	FPC	N/A	5.99

Note:

This EUT supports CDD. Physically, the EUT provides two completed transmitters and receivers (2T2R).

4. The worst case for 1TX/2TX as follow:

Operating Mode	TX Mode	1TX	2TX
IEEE 802.11a		V (Ant. 1)	-
IEEE 802.11n(HT20)		-	V (Ant. 1+Ant. 2)
IEEE 802.11n(HT40)		-	V (Ant. 1+Ant. 2)
IEEE 802.11ac(VHT20)		-	V (Ant. 1+Ant. 2)
IEEE 802.11ac(VHT40)		-	V (Ant. 1+Ant. 2)
IEEE 802.11ac(VHT80)		-	V (Ant. 1+Ant. 2)

2.2 DESCRIPTION OF TEST MODES

To investigate the maximum EMI emission characteristics generates from EUT, the test system was pre-scanning tested base on the consideration of following EUT operation mode or test configuration mode which possible have effect on EMI emission level. Each of these EUT operation mode(s) or test configuration mode(s) mentioned above was evaluated respectively.

Test Items	Mode	Data Rate	Channel	
Equivalent isotropically radiated power	IEEE 802.11a	6 Mbps	149/157/165	
	IEEE 802.11n(HT20)	MCS0		
	IEEE 802.11ac(VHT20)	MCS0		
		IEEE 802.11n(HT40)	MCS0	151/159
		IEEE 802.11ac(VHT40)	MCS0	155
		IEEE 802.11ac(VHT80)	MCS0	
Permitted range of operating frequencies	IEEE 802.11a	6 Mbps	149/165	
	IEEE 802.11ac(VHT20)	MCS0	151/159	
	IEEE 802.11ac(VHT40)	MCS0		
	IEEE 802.11ac(VHT80)	MCS0		
Unwanted emissions in the spurious domain - Operating / Standby (25MHz~1GHz)	IEEE 802.11ac(VHT20)	MCS0	149/165	
Unwanted emissions in the spurious domain - Operating / Standby (Above 1GHz)	IEEE 802.11a	6 Mbps	149/165	
	IEEE 802.11ac(VHT20)	MCS0	151/159	
	IEEE 802.11ac(VHT40)	MCS0		
	IEEE 802.11ac(VHT80)	MCS0		
Duty cycle	IEEE 802.11a	6 Mbps	149	
Adjacent channel selectivity	IEEE 802.11a	6 Mbps	157	
Blocking	IEEE 802.11a	6 Mbps	149/165	
Spurious radiation - Receiver (25MHz~1GHz)	IEEE 802.11ac(VHT20)	MCS0	149/165	
Spurious radiation - Receiver (Above 1GHz)	IEEE 802.11ac(VHT20)	MCS0	149/165	

Note :

- (1) The measurements for Power were tested, the worst case were IEEE 802.11a mode, IEEE 802.11ac(VHT20) mode, IEEE 802.11ac(VHT40) mode and IEEE 802.11ac(VHT80) mode, only worst case were documented for other test items.
- (2) For radiated spurious emissions below 1 GHz and receiver spurious emissions above 1 GHz test, the IEEE 802.11ac(VHT20) channel 149/165 are found to be the worst case and recorded.
- (3) For radiated spurious emissions above 18 GHz test, only tested the worst case and recorded.

2.3 TABLE OF PARAMETERS OF TEST SOFTWARE SETTING

During testing channel & power controlling software provided by the customer was used to control the operating channel as well as the output power level.

Test Software Version	WIFI_customer_package_Ulv2.06		
Frequency (MHz)	5745	5785	5825
IEEE 802.11a	0B	0A	0A
IEEE 802.11n(HT20)	0C	0C	0B
IEEE 802.11ac(VHT20)	0C	0C	0C
Frequency (MHz)	5755	5795	
IEEE 802.11n(HT40)	9	9	
IEEE 802.11ac(VHT40)	0B	0B	
Frequency (MHz)	5775		
IEEE 802.11ac(VHT80)	9		

2.4 BLOCK DIAGRAM SHOWING THE CONFIGURATION OF SYSTEM TESTED

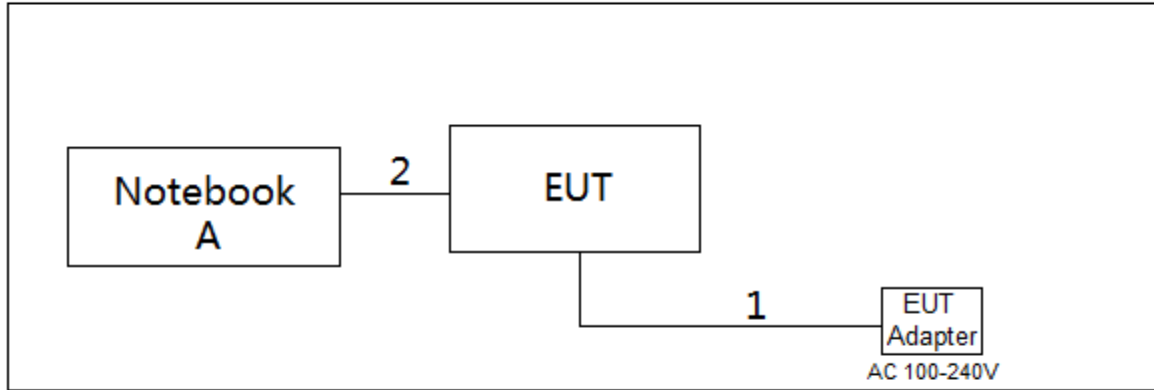

2.5 DESCRIPTION OF SUPPORT UNITS

The EUT has been tested as an independent unit together with other necessary accessories or support units. The following support units or accessories were used to form a representative test configuration during the tests.

Item	Equipment	Brand	Model No.	Series No.
A	Notebook	Huawei	NbDE-WFH9	N/A

Item	Cable Type	Shielded Type	Ferrite Core	Length
1	DC Cable	NO	NO	1.5m
2	USB Cable	NO	NO	0.5m

2.6 CUSTOMER INFORMATION DESCRIPTION

- 1) The antenna gain is provided by the manufacturer.
- 2) Except for radiated spurious emissions, the results of all test items include cable losses. Part of the cable losses (0.5dB) are provided by the manufacturer, while the other parts of the cable losses are provided by the testing laboratory.

3. EQUIVALENT ISOTROPICALLY RADIATED POWER (E.I.R.P.)

3.1 LIMITS

Clause	4.2.2.4				
Test Item	Equivalent isotropically radiated power (e.i.r.p.)				
Limits	The transmitter maximum e.i.r.p. under normal and extreme test conditions.				
	Entry	Frequency Bands	Power	Application	Notes
	1	2 400 MHz to 2 483,5 MHz	10 mW e.i.r.p.	Non-specific short range devices	
	2	2 400 MHz to 2 483,5 MHz	25 mW e.i.r.p.	Radiodetermination devices	
	3	(a) 2 446 MHz to 2 454 MHz	500 mW e.i.r.p.	Radio Frequency Identification (RFID) devices	See also table 4 and Annex G
	4	(b) 2 446 MHz to 2 454 MHz	4 W e.i.r.p.	Radio Frequency Identification (RFID) devices	See also table 4 and Annex G
	5	5 725 MHz to 5 875 MHz	25 mW e.i.r.p.	Non-specific short range devices	
	6	9 200 MHz to 9 500 MHz	25 mW e.i.r.p.	Radiodetermination devices	
	7	9 500 MHz to 9 975 MHz	25 mW e.i.r.p.	Radiodetermination devices	
	8	10,5 GHz to 10,6 GHz	500 mW e.i.r.p.	Radiodetermination devices	
	9	13,4 GHz to 14,0 GHz	25 mW e.i.r.p.	Radiodetermination devices	
	10	17,1 GHz to 17,3 GHz	400 mW e.i.r.p.	Radiodetermination devices	See Annex H
11	24,00 GHz to 24,25 GHz	100 mW e.i.r.p.	Non-specific short range devices and radiodetermination devices		
NOTE: The spectrum ranges in some entries are not harmonised throughout all EU territory, specifically entries 4, 9, and 11 have been identified as such. Implementers are cautioned to refer to CEPT/ERC Recommendation 70-03 [i.2] as well as current National Radio plans to verify acceptance within intended regions of use.					

3.2 TEST PROCEDURES

Refer to ETSI EN 300 440, chapter 4.2.2.3.

3.3 TEST SETUP LAYOUT

Normal Condition:



Extreme Condition:

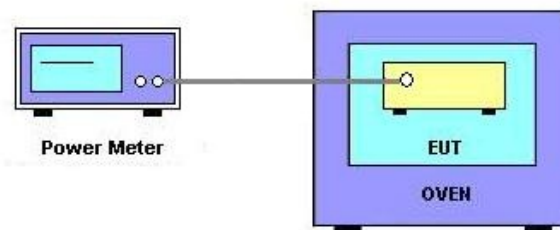

3.4 TEST DEVIATION

There is no deviation with the original standard.

3.5 EUT OPERATION DURING TEST

The measurements shall be performed during continuously transmitting.

3.6 TEST RESULTS

Please refer to the Appendix A.

4. PERMITTED RANGE OF OPERATING FREQUENCIES

4.1 LIMITS

Clause	4.2.3.5
Test Item	Permitted range of operating frequencies
Limits	<p>The width of the power spectrum envelope is $f_H - f_L$ for a given operating frequency. In equipment that allows adjustment or selection of different operating frequencies, the power envelope takes up different positions in the allowed band. The frequency range is determined by the lowest value of f_L and the highest value of f_H resulting from the adjustment of the equipment to the lowest and highest operating frequencies.</p> <p>The occupied bandwidth (i.e. the bandwidth in which 99 % of the wanted emission is contained) of the transmitter shall fall within the assigned frequency band.</p> <p>For all equipment the frequency range shall lie within the frequency band given by clause 4.2.2.4, table 2. For non-harmonized frequency bands the available frequency range may differ between national administrations.</p>

4.2 TEST PROCEDURES

Refer to ETSI EN 300 440, chapter 4.2.3.3.

4.3 TEST SETUP LAYOUT

Normal Condition:

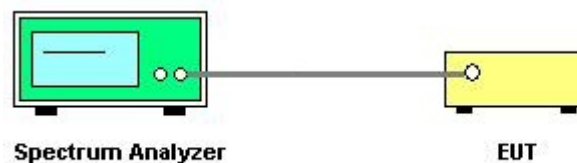

Extreme Condition:

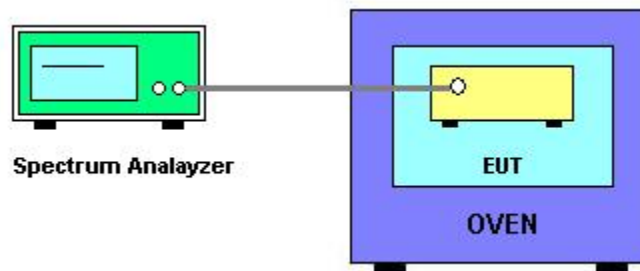

4.4 TEST DEVIATION

There is no deviation with the original standard.

4.5 EUT OPERATION DURING TEST

The measurements shall be performed during continuously transmitting.

4.6 TEST RESULTS

Please refer to the Appendix B.

5. UNWANTED EMISSIONS IN THE SPURIOUS DOMAIN

5.1 LIMITS

Clause	4.2.4.4			
Test Item	Unwanted emissions in the spurious domain			
Limits	The maximum power limits of any unwanted emissions in the spurious domain are given.			
	Frequency ranges	47 MHz to 74 MHz 87,5 MHz to 108 MHz 174 MHz to 230 MHz 470 MHz to 862 MHz	Other frequencies ≤ 1 000 MHz	Frequencies > 1 000 MHz
	State			
	Operating	4 nW	250 nW	1 μW
	Standby	2 nW	2 nW	20 nW
Note: Operating: transmitter switched on, Standby: transmitter switched off.				

5.2 TEST PROCEDURES

Refer to ETSI EN 300 440, chapter 4.2.4.3.

5.3 TEST SETUP LAYOUT

Radiated Measurement Test Set-Up Frequency Below 1 GHz

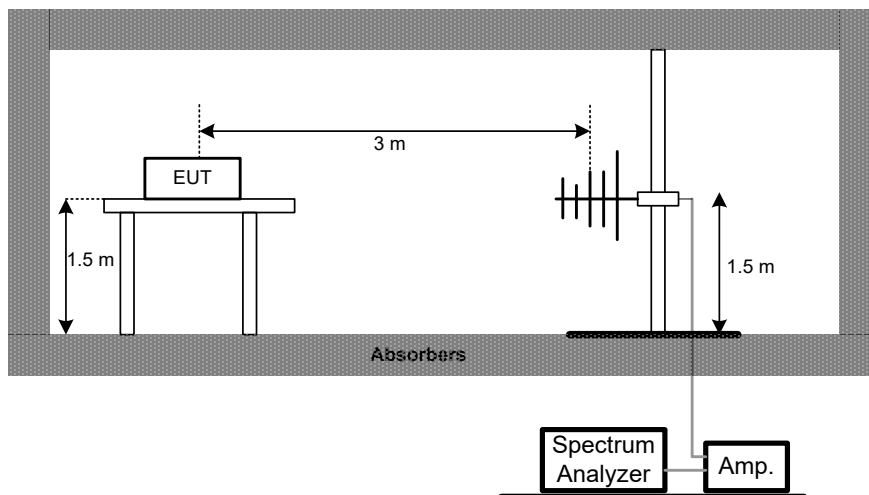

Radiated Measurement Test Set-Up Frequency 1 GHz to 18 GHz

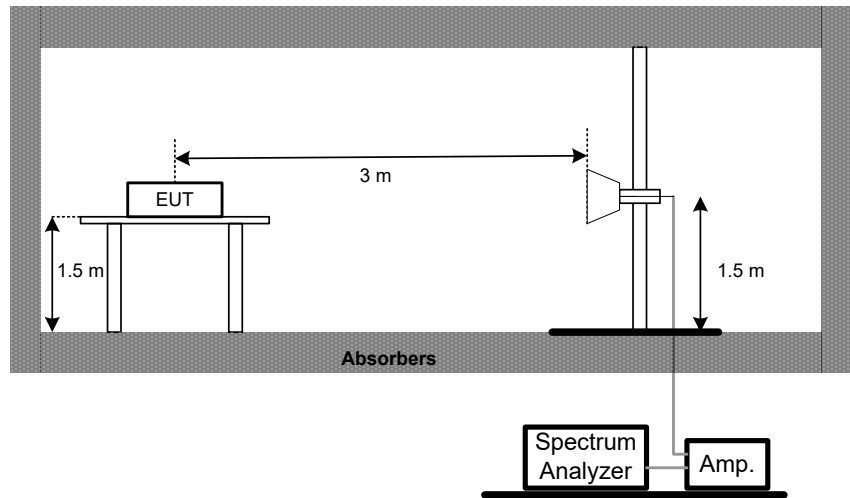

Radiated Measurement Test Set-Up Frequency Above 18 GHz

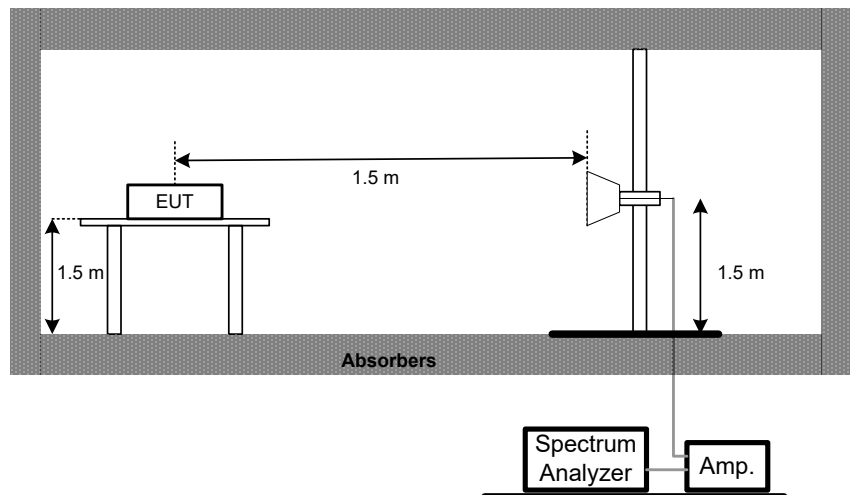

5.4 TEST DEVIATION

There is no deviation with the original standard.

5.5 EUT OPERATION DURING TEST

The measurements shall be performed during continuously transmitting.

5.6 TEST RESULTS (25MHZ TO 1000MHZ)

Please refer to the Appendix C for operating mode.

Please refer to the Appendix D for standby mode.

5.7 TEST RESULTS (ABOVE 1000MHZ)

Please refer to the Appendix E for operating mode.

Please refer to the Appendix F for standby mode.

6. DUTY CYCLE

6.1 LIMITS

Clause	4.2.5.4			
Test Item	Duty cycle			
Limits	Frequency Band	Duty cycle	Application	Notes
	2 400 MHz to 2 483,5 MHz	No Restriction	Generic use	
	2 400 MHz to 2 483,5 MHz	No Restriction	Radiodetermination	
	(a) 2 446 MHz to 2 454 MHz	No Restriction	RFID	Limits shown in Annex G shall apply
	(b) 2 446 MHz to 2 454 MHz	≤ 15 %	RFID	Limits shown in Annex G shall apply
	5 725 MHz to 5 875 MHz	No Restriction	Generic use	
	9 200 MHz to 9 500 MHz	No Restriction	Radiodetermination	
	9 500 MHz to 9 975 MHz	No Restriction	Radiodetermination	
	10,5 GHz to 10,6 GHz	No Restriction	Radiodetermination	
	13,4 GHz to 14,0 GHz	No Restriction	Radiodetermination	
	17,1 GHz to 17,3 GHz	DAA or equivalent techniques	Radiodetermination, limited to GBSAR detecting and movement and alert applications	Limits shown in Annex I shall apply
	24,00 GHz to 24,25 GHz	No Restriction	Generic use and for radiodetermination	
NOTE: The spectrum ranges in some entries are not harmonised throughout all EU territory, specifically entries 4, 9, and 11 have been identified as such. Implementers are cautioned to refer to CEPT/ERC Recommendation 70-03 [i.2] as well as current National Radio plans to verify acceptance within intended regions of use.				
Note: The maximum duty cycle within a 1 hour period.				

6.2 TEST PROCEDURES

Refer to ETSI EN 300 440, chapter 4.2.5.3.

6.3 TEST SETUP LAYOUT



6.4 TEST DEVIATION

There is no deviation with the original standard.

6.5 EUT OPERATION DURING TEST

The measurements shall be performed during normal transmitting.

6.6 TEST RESULTS

Please refer to the Appendix G.

7. ADJACENT CHANNEL SELECTIVITY

7.1 LIMITS

Clause	4.3.3.4
Test Item	Adjacent channel selectivity
Limits	<p>The adjacent channel selectivity of the equipment under specified conditions shall not be less than $-30 \text{ dBm} + k$.</p> <p>The correction factor, k, is as follows:</p> $k = -20 \log f - 10 \log BW$ <p>Where:</p> <ul style="list-style-type: none"> - f is the frequency in GHz; - BW is the occupied bandwidth in MHz. <p>The factor k is limited within the following:</p> <ul style="list-style-type: none"> - $-40 \text{ dB} < k < 0 \text{ dB}$.

7.2 TEST PROCEDURES

Refer to ETSI EN 300 440, chapter 4.3.3.3.

7.3 TEST SETUP LAYOUT

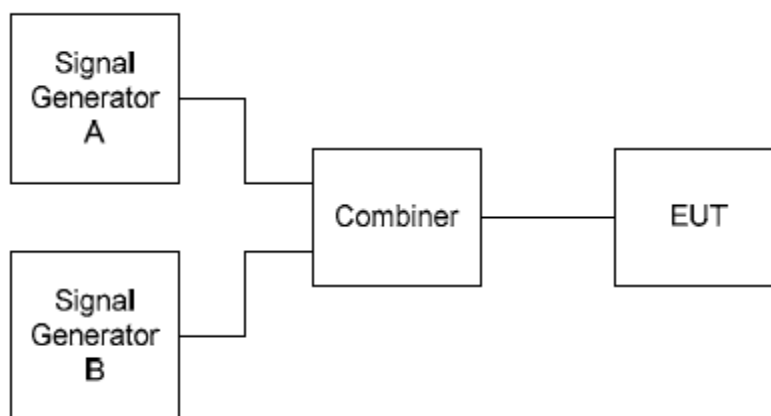

7.4 TEST DEVIATION

There is no deviation with the original standard.

7.5 EUT OPERATION DURING TEST

The measurements shall be performed during normal receiving.

7.6 TEST RESULTS

Please refer to the Appendix H.

8. BLOCKING OR DESENSITIZATION

8.1 LIMITS

Clause	4.3.4.4							
Test Item	Blocking or desensitization							
Limits	The blocking level, for any frequency within the specified ranges, shall not be less than the values given in table, except at frequencies on which spurious responses are found.							
	<table border="1"> <thead> <tr> <th>Receiver category</th> <th>Limit</th> </tr> </thead> <tbody> <tr> <td>1</td> <td>-30 dBm + k</td> </tr> <tr> <td>2</td> <td>-45 dBm + k</td> </tr> <tr> <td>3</td> <td>-60 dBm + k</td> </tr> </tbody> </table> <p>The correction factor, k, is as follows: $k = -20 \log f - 10 \log BW$</p> <p>Where:</p> <ul style="list-style-type: none"> - f is the frequency in GHz; - BW is the occupied bandwidth in MHz. <p>The factor k is limited within the following:</p> <ul style="list-style-type: none"> - $-40 \text{ dB} < k < 0 \text{ dB}$. 	Receiver category	Limit	1	-30 dBm + k	2	-45 dBm + k	3
Receiver category	Limit							
1	-30 dBm + k							
2	-45 dBm + k							
3	-60 dBm + k							

8.2 TEST PROCEDURES

Refer to ETSI EN 300 440, chapter 4.3.4.3.

8.3 TEST SETUP LAYOUT

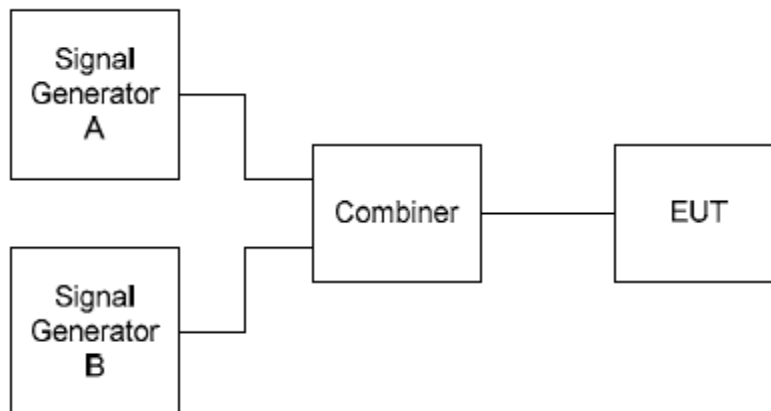

8.4 TEST DEVIATION

There is no deviation with the original standard.

8.5 EUT OPERATION DURING TEST

The measurements shall be performed during normal receiving.

8.6 TEST RESULTS

Please refer to the Appendix I.

9. SPURIOUS RADIATIONS

9.1 LIMITS

Clause	4.3.5.4		
Test Item	Spurious radiations		
Limit	The power of any spurious emission shall not exceed 2 nW in the range 25 MHz to 1 GHz and shall not exceed 20 nW on frequencies above 1 GHz.		
	Other frequencies 25 MHz to 1000 MHz	Frequencies Above 1000 MHz	
	2 nW (-57dBm)	20 nW (-47dBm)	

9.2 TEST PROCEDURES

Refer to ETSI EN 300 440, chapter 4.3.5.3.

9.3 TEST SETUP LAYOUT

Refer to clause 5.3.

9.4 TEST DEVIATION

There is no deviation with the original standard.

9.5 EUT OPERATION DURING TEST

The measurements shall be performed during continuously receiving.

9.6 TEST RESULTS (25MHZ TO 1000MHZ)

Please refer to the Appendix J.

9.7 TEST RESULTS (ABOVE 1000MHZ)

Please refer to the Appendix K.

10. MEASUREMENT INSTRUMENTS LIST

Equivalent Isotropically Radiated Power (e.i.r.p.)					
Item	Kind of Equipment	Manufacturer	Type No.	Serial No.	Calibrated until
1	Table top type high and low temperature test chamber	CEPREI	CEEC-M64T-40	15-008	Dec. 22, 2024
2	Power Sensor	Agilent	U2021XA	MY53320006	May 31, 2025
3	Power Sensor	Agilent	U2021XA	MY53340001	May 31, 2025
4	Cable	Woke	20210802 001	RWP50-402-SM SM-1M	N/A
5	Cable	RegalWay	S02-181212-308	RWP50-402-SM SM-1M	N/A
6	BTL TestSystem	BTL	TestSoftware	N/A	N/A
7	Attenuator	Talent Microwave	TA10A2-S-18	N/A	N/A
8	Attenuator	Talent Microwave	TA10A2-S-18	N/A	N/A
9	Multi-output DC Power Supply	GW Instek	GPC-3030DN	EK880675	Jul. 07, 2024

Permitted Range of Operating Frequency					
Item	Kind of Equipment	Manufacturer	Type No.	Serial No.	Calibrated until
1	Spectrum Analyzer	R&S	FSP40	100185	May 31, 2025
2	Attenuator	Talent Microwave	TA10A0-S-26.5	N/A	N/A
3	DC Block	N/A	N/A	N/A	N/A
4	Measurement Software	BTL	BTL Conducted Test	N/A	N/A
5	Desktop Constant Temperature Chamber	BELL	BTH-50C	20170306001	Jan. 19, 2025
6	DC power supply	UNI-T	UDP6721	AWP7224050031	Mar. 20, 2025
7	Cable	Woke	S02-181212-064	N/A	N/A

Transmitter and Receiver Spurious Emission (Radiated Measurement)_Below 1GHz

Item	Kind of Equipment	Manufacturer	Type No.	Serial No.	Calibrated until
1	Preamplifier	EMC INSTRUMENT	EMC001330	980986	May 31, 2025
2	EXA Signal Analyzer	Keysight	N9010A	MY56480488	Dec. 22, 2024
3	Antenna	Schwarzbeck	VULB9160	9160-3231	Apr. 14, 2025
4	Attenuator	SHX	TS2-6dB-6G-A	16101103	Apr. 14, 2025
5	Cable	Talent microwave	L6-NMNM-10M	N/A	N/A
6	Cable	RegalWay	LMR400-NMRANM-0.8M	N/A	N/A
7	Controller	Innco Systems Gmbh	CO3000-4port	CO3000/1155/4 5430119/P	N/A
8	Measurement Software	Farad	EZ-EMC Ver.NB-03A1-01	N/A	N/A

Transmitter and Receiver Spurious Emission (Radiated Measurement)_Above 1GHz

Item	Kind of Equipment	Manufacturer	Type No.	Serial No.	Calibrated until
1	Pre-Amplifier	EMC INSTRUMENT	EMC184045SE	980409	Dec. 22, 2024
2	EXA Signal Analyzer	Keysight	N9010A	MY56480488	Dec. 22, 2024
3	DRG Horn Antenna	ETS	3116C	218942	Mar. 02, 2025
4	DRG Horn Antenna	ETS	3117-PA	221576	Jul. 07, 2024
5	Preamplifier	ETS	3117-PA	221576	May 31, 2025
6	Cable	Talent microwave	A81-SMAMSMAM-12.5M	N/A	N/A
7	Cable	RegalWay	RWLP50-4.0A-SMR ANMRA-2M	N/A	N/A
8	Cable	Tonscend	HF160-KMKM-5.00 M	N/A	N/A
9	Cable	Tonscend	HF160-KMKM-0.5M	N/A	N/A
10	Measurement Software	Farad	EZ-EMC Ver.NB-03A1-01	N/A	N/A
11	Controller	Innco Systems Gmbh	CO3000-4port	CO3000/1155/4 5430119/P	N/A
12	Attenuator	Talent Microwave	TA10A0-S-26.5	N/A	N/A
13	Filter	STI	STI15-9969	N/A	May 31, 2025

Duty Cycle & OBW

Item	Kind of Equipment	Manufacturer	Type No.	Serial No.	Calibrated until
1	Spectrum Analyzer	R&S	FSP40	100185	May 31, 2025
2	Attenuator	Talent Microwave	TA10A0-S-26.5	N/A	N/A
3	DC Block	N/A	N/A	N/A	N/A
4	Measurement Software	BTL	BTL Conducted Test	N/A	N/A

Adjacent channel selectivity & Blocking					
Item	Kind of Equipment	Manufacturer	Type No.	Serial No.	Calibrated until
1	Cable	RegalWay	20210802 013	RWP50-402-SM SM-1M	N/A
2	Cable	RegalWay	S02-1081212-050	RWP50-402-SM SM-1M	N/A
3	DC Block	N/A	N/A	N/A	N/A
4	DC Block	N/A	N/A	N/A	N/A
5	MXG Vector Signal Generator	Agilent	N5182A	MY47420312	Jul. 07, 2025
6	Power Splitter	N/A	N/A	SZ201504789	Dec. 22, 2024
7	wideband radio communication tester	R&S	CMW500	152372	Dec. 22, 2024

Remark: "N/A" denotes no model name, serial no. or calibration specified.

All calibration period of equipment list is one year.

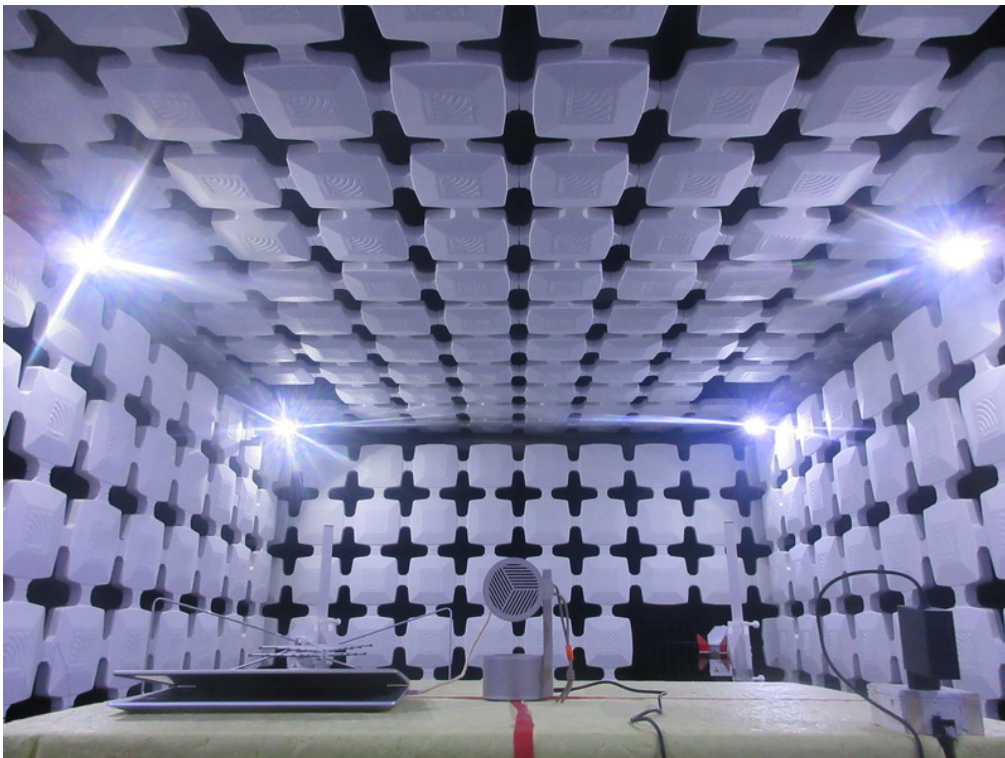
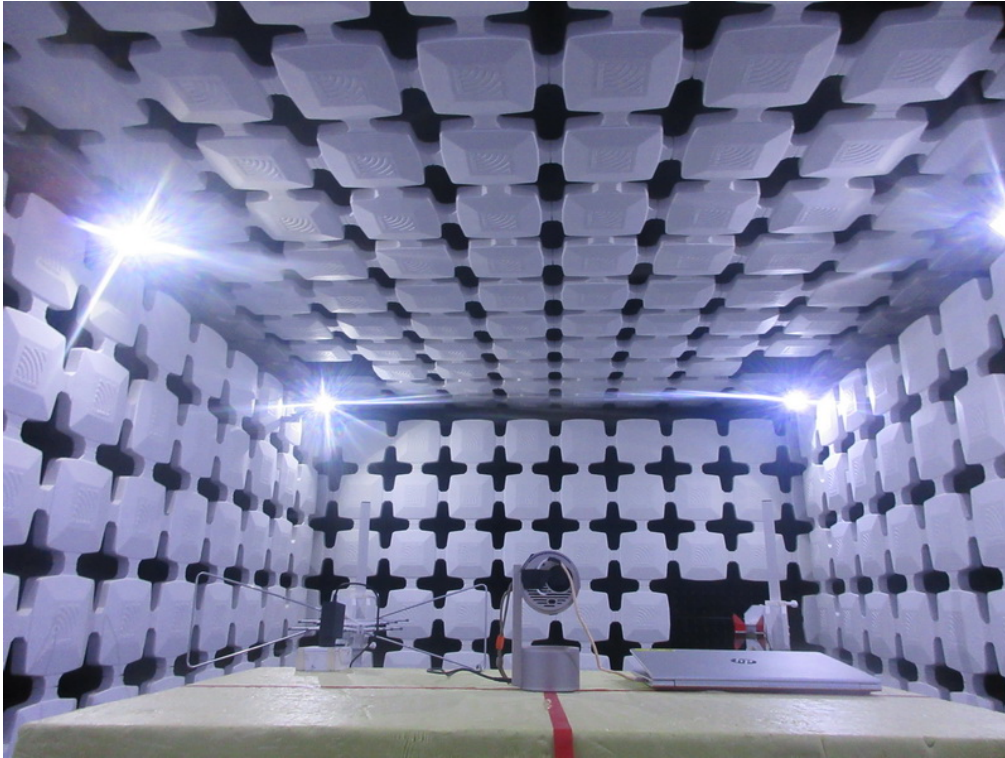
11. EUT TEST PHOTO**Radiated Emissions Test Photos_Below 18GHz**

Radiated Emissions Test Photos_Above 18GHz

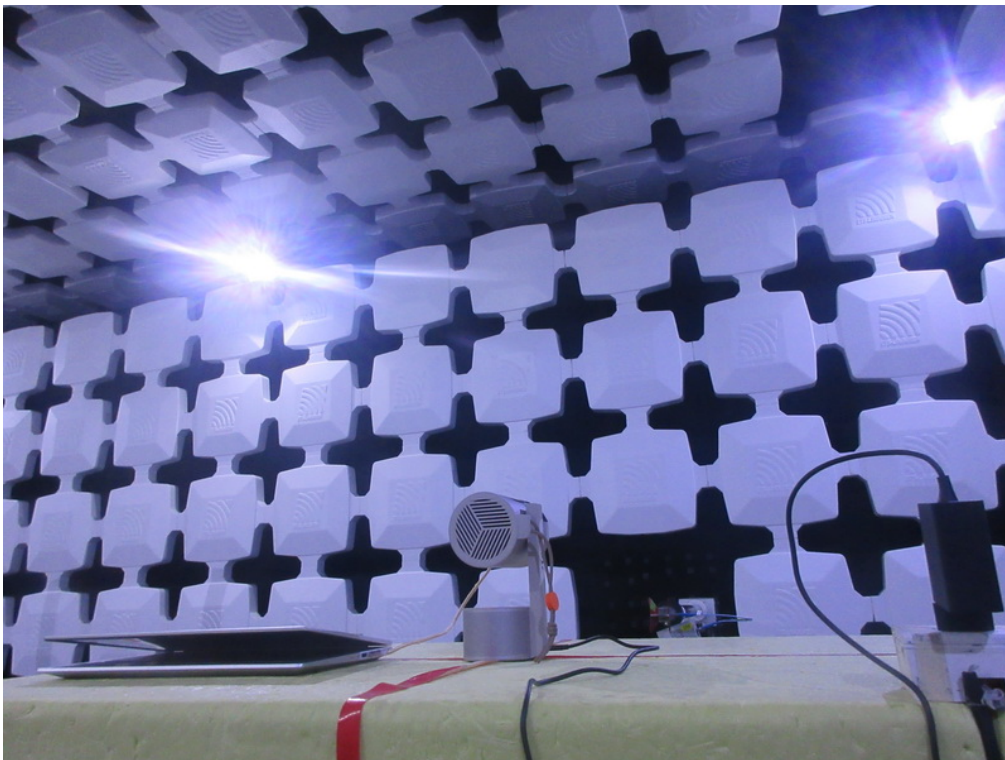
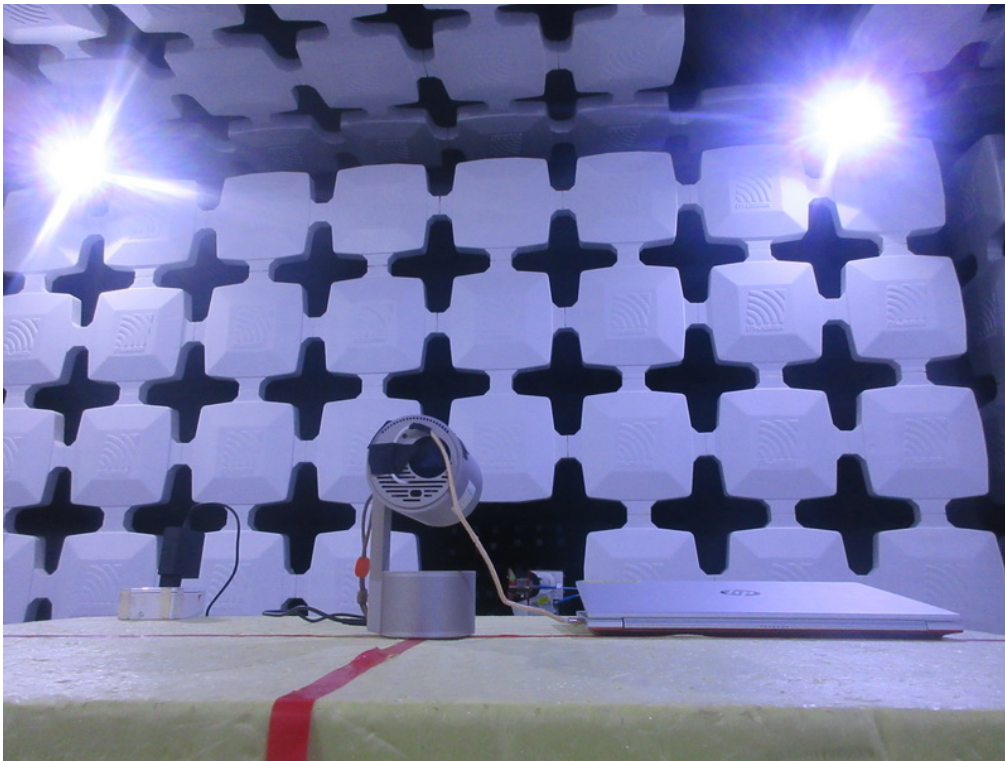

APPENDIX A - EQUIVALENT ISOTROPICALLY RADIATED POWER

Test Mode: IEEE 802.11a Mode						
Test Conditions				Average e.i.r.p. (dBm)		
				CH149	CH157	CH165
T _{nom} (°C)	22	V _{nom} (V)	12.0	13.33	12.82	13.46
T _{min} (°C)	0	V _{max} (V)	13.2	13.66	13.19	13.81
		V _{min} (V)	10.8	13.67	13.11	13.72
T _{max} (°C)	40	V _{max} (V)	13.2	13.11	12.62	13.16
		V _{min} (V)	10.8	13.05	12.64	13.29
Max. e.i.r.p.				13.81		
Limits				13.98dBm (25mW)		
Result				Pass		

Test Mode: IEEE 802.11n(HT20) Mode						
Test Conditions				Average e.i.r.p. (dBm)		
				CH149	CH157	CH165
T _{nom} (°C)	22	V _{nom} (V)	12.0	13.54	13.47	12.80
T _{min} (°C)	0	V _{max} (V)	13.2	13.89	13.86	13.20
		V _{min} (V)	10.8	13.85	13.84	13.22
T _{max} (°C)	40	V _{max} (V)	13.2	13.22	13.23	12.48
		V _{min} (V)	10.8	13.26	13.17	12.52
Max. e.i.r.p.				13.89		
Limits				13.98dBm (25mW)		
Result				Pass		

Test Mode: IEEE 802.11n(HT40) Mode						
Test Conditions				Average e.i.r.p. (dBm)		
				CH151	CH159	
T _{nom} (°C)	22	V _{nom} (V)	12.0	12.92	12.88	
T _{min} (°C)	0	V _{max} (V)	13.2	13.30	13.32	
		V _{min} (V)	10.8	13.26	13.28	
T _{max} (°C)	40	V _{max} (V)	13.2	12.57	12.66	
		V _{min} (V)	10.8	12.63	12.53	
Max. e.i.r.p.				13.32		
Limits				13.98dBm (25mW)		
Result				Pass		

Test Mode: IEEE 802.11ac(VHT20) Mode						
Test Conditions				Average e.i.r.p. (dBm)		
				CH149	CH157	CH165
T _{nom} (°C)	22	V _{nom} (V)	12.0	13.66	13.63	13.66
T _{min} (°C)	0	V _{max} (V)	13.2	13.92	13.95	13.87
		V _{min} (V)	10.8	13.93	13.88	13.90
T _{max} (°C)	40	V _{max} (V)	13.2	13.36	13.31	13.07
		V _{min} (V)	10.8	13.37	13.37	13.34
Max. e.i.r.p.				13.95		
Limits				13.98dBm (25mW)		
Result				Pass		

Test Mode: IEEE 802.11ac(VHT40) Mode					
Test Conditions				Average e.i.r.p. (dBm)	
				CH151	CH159
T _{nom} (°C)	22	V _{nom} (V)	12.0	13.19	13.37
T _{min} (°C)	0	V _{max} (V)	13.2	13.43	13.62
		V _{min} (V)	10.8	13.53	13.76
T _{max} (°C)	40	V _{max} (V)	13.2	12.85	13.18
		V _{min} (V)	10.8	13.01	13.19
Max. e.i.r.p.				13.76	
Limits				13.98dBm (25mW)	
Result				Pass	

Test Mode: IEEE 802.11ac(VHT80) Mode				
Test Conditions				Average e.i.r.p. (dBm)
				CH155
T _{nom} (°C)	22	V _{nom} (V)	12.0	13.61
T _{min} (°C)	0	V _{max} (V)	13.2	13.90
		V _{min} (V)	10.8	13.94
T _{max} (°C)	40	V _{max} (V)	13.2	13.32
		V _{min} (V)	10.8	13.42
Max. e.i.r.p.				13.94
Limits				13.98dBm (25mW)
Result				Pass

Note:

- 1) e.i.r.p. = Conducted output power + G (Ant Gain)
- 2) Conducted output power = Measure result + Cable loss

APPENDIX B - PERMITTED RANGE OF OPERATING FREQUENCIES

Test Mode: IEEE 802.11a Mode					
Test Conditions				Frequency Range (MHz)	
				f_L CH149	f_H CH165
T_{nom} (°C)	24-26	V_{nom} (V)	12.0	5736.2000	5833.7000
T_{min} (°C)	0	V_{max} (V)	13.2	5735.8000	5833.8000
		V_{min} (V)	10.8	5735.8000	5833.7000
T_{max} (°C)	40	V_{max} (V)	13.2	5736.2000	5833.7000
		V_{min} (V)	10.8	5736.2000	5833.7000
Min. f_L / Max. f_H Band Edges				5735.8000	5833.8000
Limits				$f_L > 5725.0$ MHz	$f_H < 5875.0$ MHz
Result				Pass	

Test Mode: IEEE 802.11a Mode			
Test Conditions		Occupied Channel Bandwidth (MHz)	
		CH149	CH165
T_{nom} (°C)	24-26	16.60	16.60
F_L OBW		5736.70	-
F_H OBW		-	5833.30
Limits		$f_L > 5725.0$ MHz	$f_H < 5875.0$ MHz

Test Mode: IEEE 802.11ac(VHT20) Mode					
Test Conditions				Frequency Range (MHz)	
				f_L CH149	f_H CH165
T_{nom} (°C)	24-26	V_{nom} (V)	12.0	5735.8000	5834.1000
T_{min} (°C)	0	V_{max} (V)	13.2	5735.6000	5834.3000
		V_{min} (V)	10.8	5735.6000	5834.3000
T_{max} (°C)	40	V_{max} (V)	13.2	5735.8000	5834.1000
		V_{min} (V)	10.8	5735.8000	5834.1000
Min. f_L / Max. f_H Band Edges				5735.6000	5834.3000
Limits				$f_L > 5725.0$ MHz	$f_H < 5875.0$ MHz
Result				Pass	

Test Mode: IEEE 802.11ac(VHT20) Mode			
Test Conditions		Occupied Channel Bandwidth (MHz)	
		CH149	CH165
T_{nom} (°C)	24-26	17.70	17.60
F_L OBW		5736.10	-
F_H OBW		-	5833.80
Limits		$f_L > 5725.0$ MHz	$f_H < 5875.0$ MHz

Test Mode: IEEE 802.11ac(VHT40) Mode					
Test Conditions				Frequency Range (MHz)	
				f_L CH151	f_H CH159
T_{nom} (°C)	24-26	V_{nom} (V)	12.0	5736.6000	5813.2000
T_{min} (°C)	0	V_{max} (V)	13.2	5736.6000	5813.4000
		V_{min} (V)	10.8	5736.6000	5813.4000
T_{max} (°C)	40	V_{max} (V)	13.2	5736.6000	5813.2000
		V_{min} (V)	10.8	5736.6000	5813.2000
Min. f_L / Max. f_H Band Edges				5736.6000	5813.4000
Limits				$f_L > 5725.0$ MHz	$f_H < 5875.0$ MHz
Result				Pass	

Test Mode: IEEE 802.11ac(VHT40) Mode				
Test Conditions			Occupied Channel Bandwidth (MHz)	
			CH151	CH159
T_{nom} (°C)	24-26		36.40	36.60
F_L OBW			5736.80	-
F_H OBW			-	5813.20
Limits			$f_L > 5725.0$ MHz	$f_H < 5875.0$ MHz

Test Mode: IEEE 802.11ac(VHT80) Mode					
Test Conditions				Frequency Range (MHz)	
				f_L CH155	f_H CH155
T_{nom} (°C)	24-26	V_{nom} (V)	12.0	5736.6000	5813.4000
T_{min} (°C)	0	V_{max} (V)	13.2	5736.6000	5813.4000
		V_{min} (V)	10.8	5736.6000	5813.4000
T_{max} (°C)	40	V_{max} (V)	13.2	5736.6000	5813.4000
		V_{min} (V)	10.8	5736.6000	5813.4000
Min. f_L / Max. f_H Band Edges				5736.6000	5813.4000
Limits				$f_L > 5725.0$ MHz	$f_H < 5875.0$ MHz
Result				Pass	

Test Mode: IEEE 802.11ac(VHT80) Mode		
Test Conditions		Occupied Channel Bandwidth (MHz)
		CH155
T_{nom} (°C)	24-26	76.00
F_L OBW		5737.00
F_H OBW		5813.00
Limits		$f_L > 5725.0$ MHz $f_H < 5875.0$ MHz

APPENDIX C - UNWANTED EMISSIONS IN THE SPURIOUS DOMAIN - OPERATING (25MHZ TO 1000MHZ)

Test Mode	TX IEEE 802.11ac(VHT20) Mode 5745 MHz	Polarization	Vertical
-----------	---------------------------------------	--------------	----------

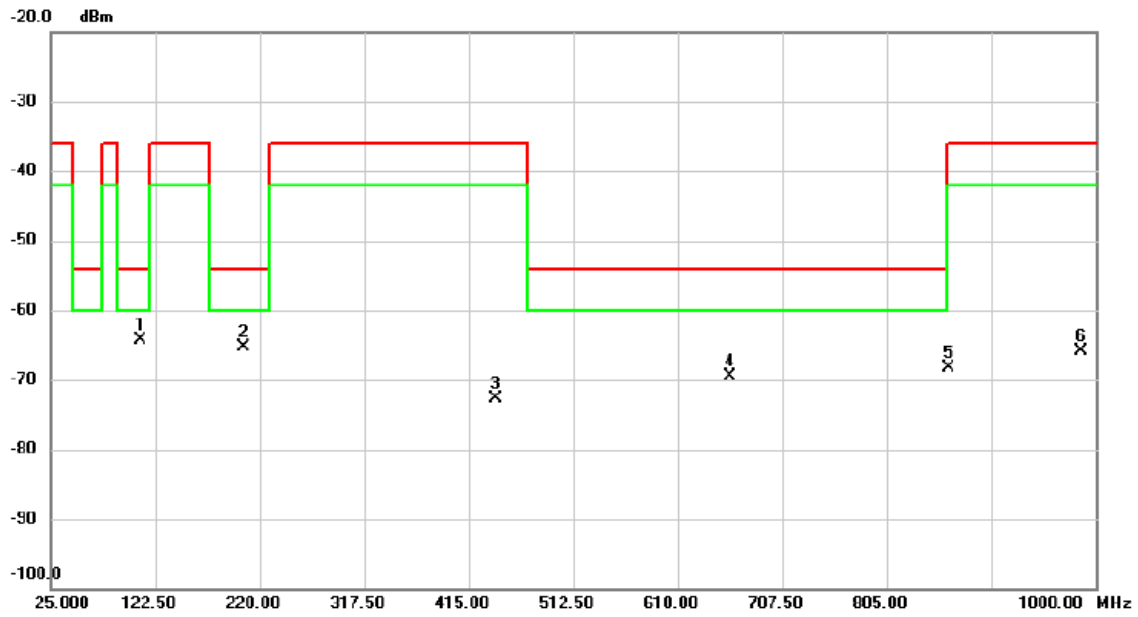

No.	Mk.	Freq. MHz	Reading Level dBm	Correct Factor dB	Measure- ment dBm	Limit dBm	Margin dB	Detector	Comment
1	*	109.435	-60.71	-3.66	-64.37	-54.00	-10.37	peak	
2		205.180	-61.69	-3.64	-65.33	-54.00	-11.33	peak	
3		440.545	-74.99	2.28	-72.71	-36.00	-36.71	peak	
4		658.945	-74.90	5.44	-69.46	-54.00	-15.46	peak	
5		862.428	-75.78	7.54	-68.24	-36.00	-32.24	peak	
6		985.862	-75.59	9.62	-65.97	-36.00	-29.97	peak	

Test Mode	TX IEEE 802.11ac(VHT20) Mode 5745 MHz	Polarization	Horizontal
-----------	---------------------------------------	--------------	------------

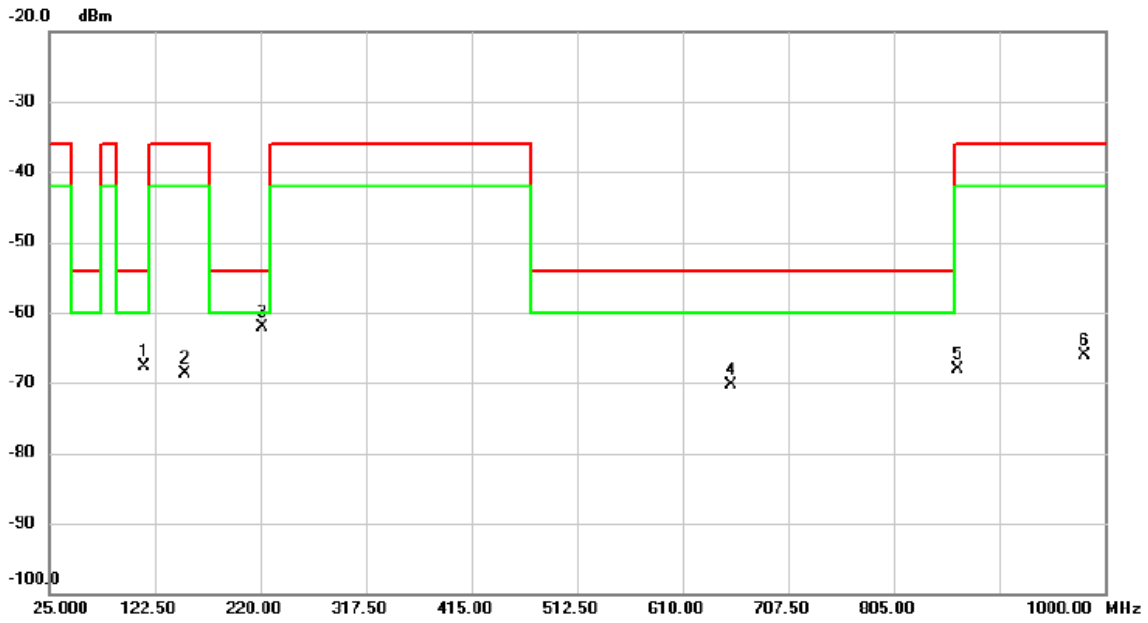

No. Mk.	Freq. MHz	Reading Level dBm	Correct Factor dB	Measurement dBm	Limit dBm	Margin dB	Detector	Comment
1	112.945	-63.62	-4.01	-67.63	-54.00	-13.63	peak	
2	149.898	-69.86	1.16	-68.70	-36.00	-32.70	peak	
3 *	221.852	-59.79	-2.22	-62.01	-54.00	-8.01	peak	
4	654.558	-75.82	5.56	-70.26	-54.00	-16.26	peak	
5	864.183	-75.90	7.77	-68.13	-36.00	-32.13	peak	
6	981.085	-76.13	9.96	-66.17	-36.00	-30.17	peak	

Test Mode	TX IEEE 802.11ac(VHT20) Mode 5825 MHz	Polarization	Vertical
-----------	---------------------------------------	--------------	----------

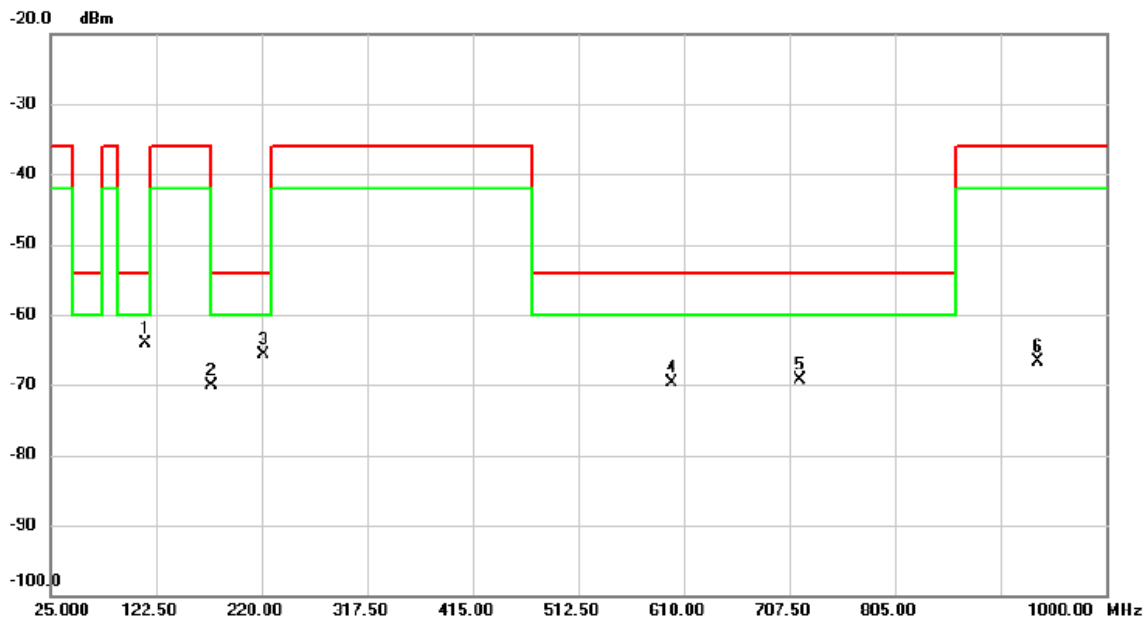

No.	Mk.	Freq. MHz	Reading Level dBm	Correct Factor dB	Measure- ment dBm	Limit dBm	Margin dB	Detector	Comment
1	*	112.750	-60.74	-3.45	-64.19	-54.00	-10.19	peak	
2		174.370	-68.84	-1.24	-70.08	-54.00	-16.08	peak	
3		221.852	-62.81	-2.82	-65.63	-54.00	-11.63	peak	
4		598.690	-74.59	4.91	-69.68	-54.00	-15.68	peak	
5		716.957	-75.72	6.44	-69.28	-54.00	-15.28	peak	
6		937.015	-75.86	9.17	-66.69	-36.00	-30.69	peak	

Test Mode	TX IEEE 802.11ac(VHT20) Mode 5825 MHz	Polarization	Horizontal
-----------	---------------------------------------	--------------	------------

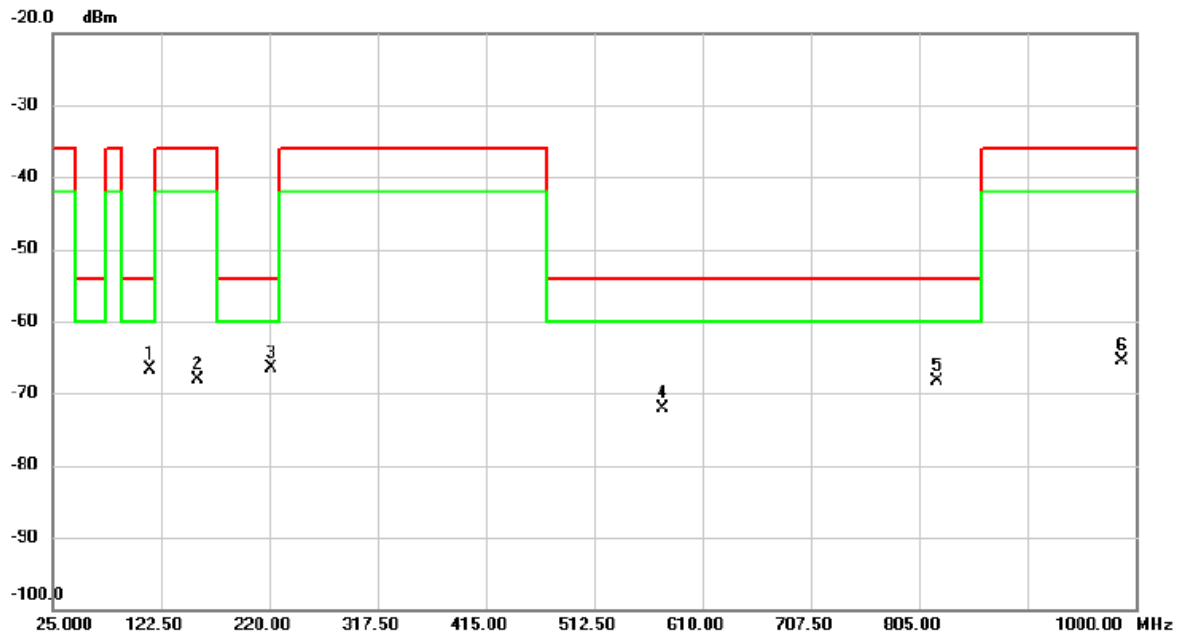

No.	Mk.	Freq. MHz	Reading Level dBm	Correct Factor dB	Measure- ment dBm	Limit dBm	Margin dB	Detector	Comment
1		112.847	-62.66	-4.03	-66.69	-54.00	-12.69	peak	
2		155.357	-68.69	0.58	-68.11	-36.00	-32.11	peak	
3	*	221.852	-64.20	-2.22	-66.42	-54.00	-12.42	peak	
4		574.217	-76.37	4.32	-72.05	-54.00	-18.05	peak	
5		821.087	-76.04	7.77	-68.27	-54.00	-14.27	peak	
6		987.813	-75.44	10.04	-65.40	-36.00	-29.40	peak	

APPENDIX D - UNWANTED EMISSIONS IN THE SPURIOUS DOMAIN - STANDBY (25MHZ TO 1000MHZ)

Test Mode: N/A

Note: "N/A" denotes test is not applicable to this device.

**APPENDIX E - UNWANTED EMISSIONS IN THE SPURIOUS
DOMAIN - OPERATING (ABOVE 1000MHZ)**

Test Mode	TX IEEE 802.11a Mode 5745 MHz	Polarization	Vertical
-----------	-------------------------------	--------------	----------

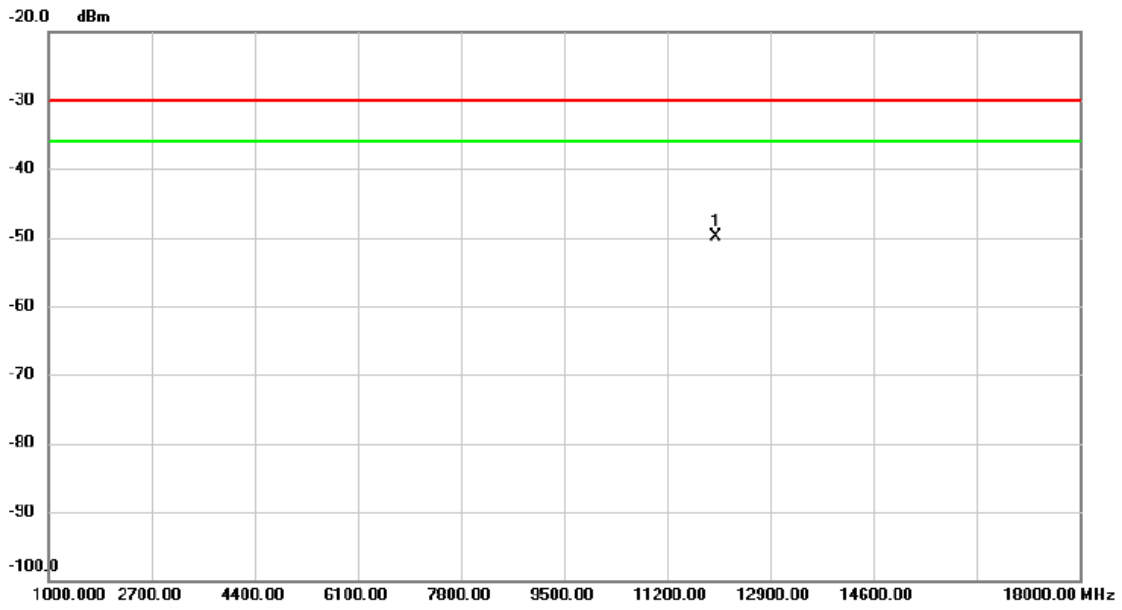

No. Mk.	Freq. MHz	Reading Level dBm	Correct Factor dB	Measurement dBm	Limit dBm	Margin dB	Detector	Comment
1 *	12015.150	-57.98	8.02	-49.96	-30.00	-19.96	peak	

Test Mode	TX IEEE 802.11a Mode 5745 MHz	Polarization	Horizontal
-----------	-------------------------------	--------------	------------

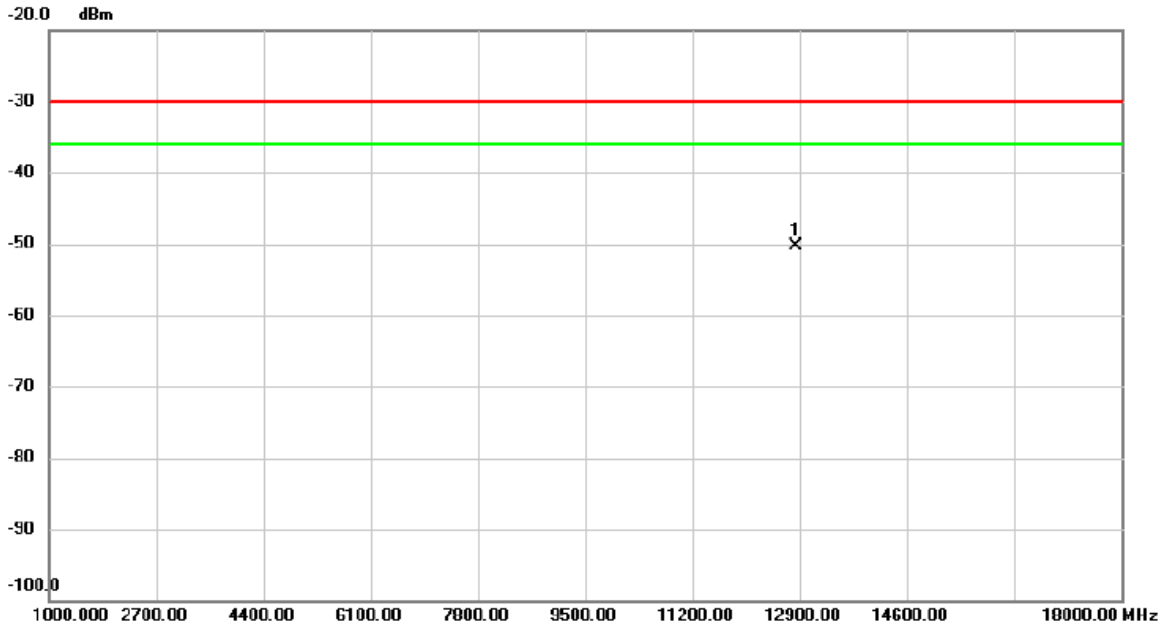

No.	Mk.	Freq. MHz	Reading Level dBm	Correct Factor dB	Measure- ment dBm	Limit dBm	Margin dB	Detector	Comment
1	*	12849.850	-58.22	8.02	-50.20	-30.00	-20.20	peak	

Test Mode	TX IEEE 802.11a Mode 5825 MHz	Polarization	Vertical
-----------	-------------------------------	--------------	----------

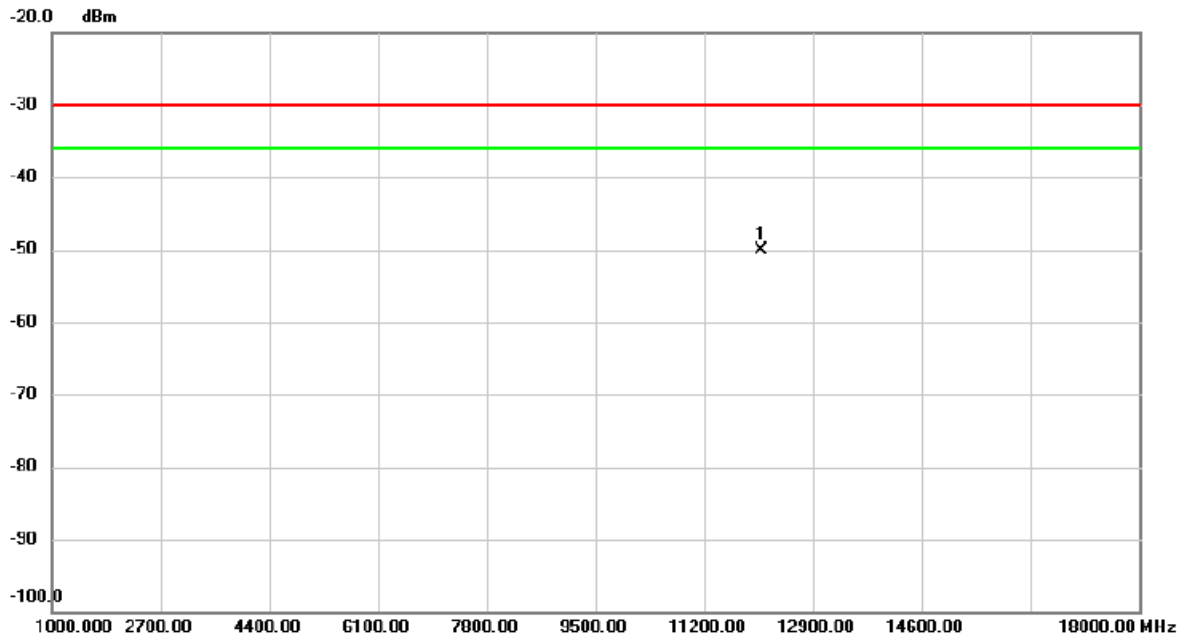

No.	Mk.	Freq. MHz	Reading Level dBm	Correct Factor dB	Measure- ment dBm	Limit dBm	Margin dB	Detector	Comment
1	*	12094.200	-58.20	8.15	-50.05	-30.00	-20.05	peak	

Test Mode	TX IEEE 802.11a Mode 5825 MHz	Polarization	Horizontal
-----------	-------------------------------	--------------	------------

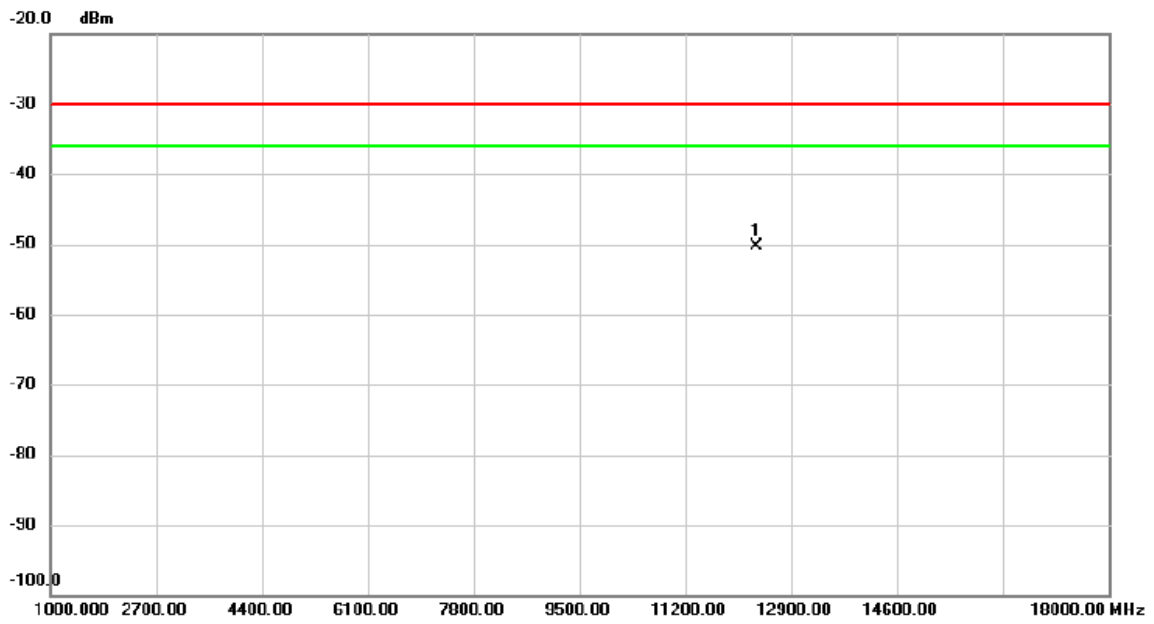

No.	Mk.	Freq. MHz	Reading Level dBm	Correct Factor dB	Measure- ment dBm	Limit dBm	Margin dB	Detector	Comment
1	*	12339.000	-58.89	8.68	-50.21	-30.00	-20.21	peak	

Test Mode	TX IEEE 802.11ac(VHT20) Mode 5745 MHz	Polarization	Vertical
-----------	---------------------------------------	--------------	----------

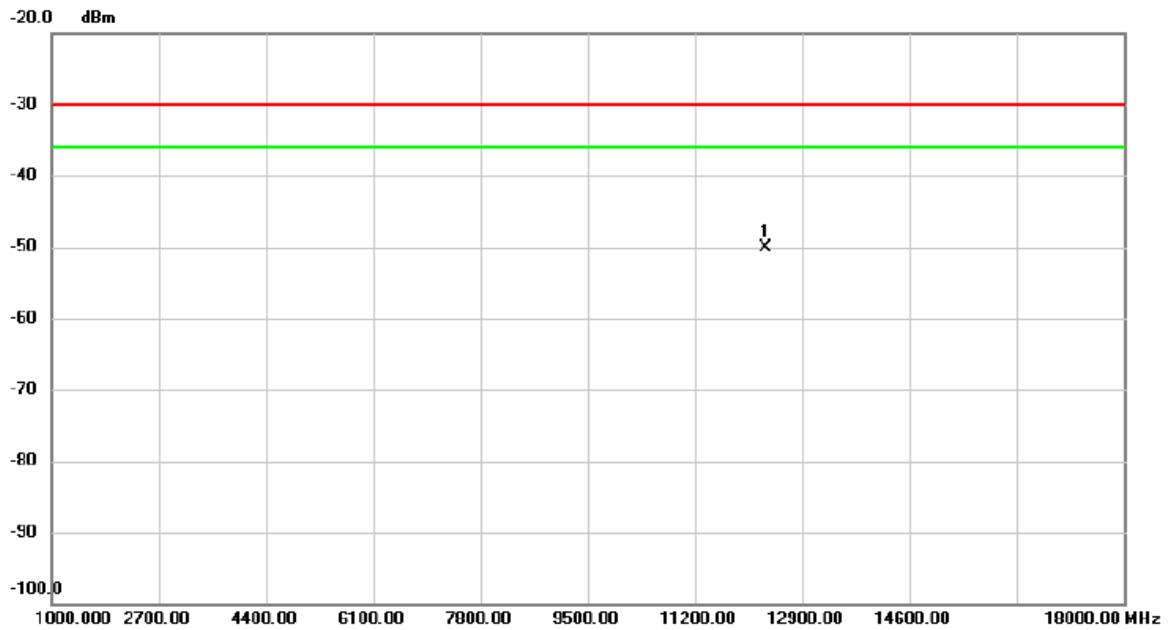

No.	Mk.	Freq. MHz	Reading Level dBm	Correct Factor dB	Measure- ment dBm	Limit dBm	Margin dB	Detector	Comment
1	*	12312.650	-58.57	8.51	-50.06	-30.00	-20.06	peak	

Test Mode	TX IEEE 802.11ac(VHT20) Mode 5745 MHz	Polarization	Horizontal
-----------	---------------------------------------	--------------	------------

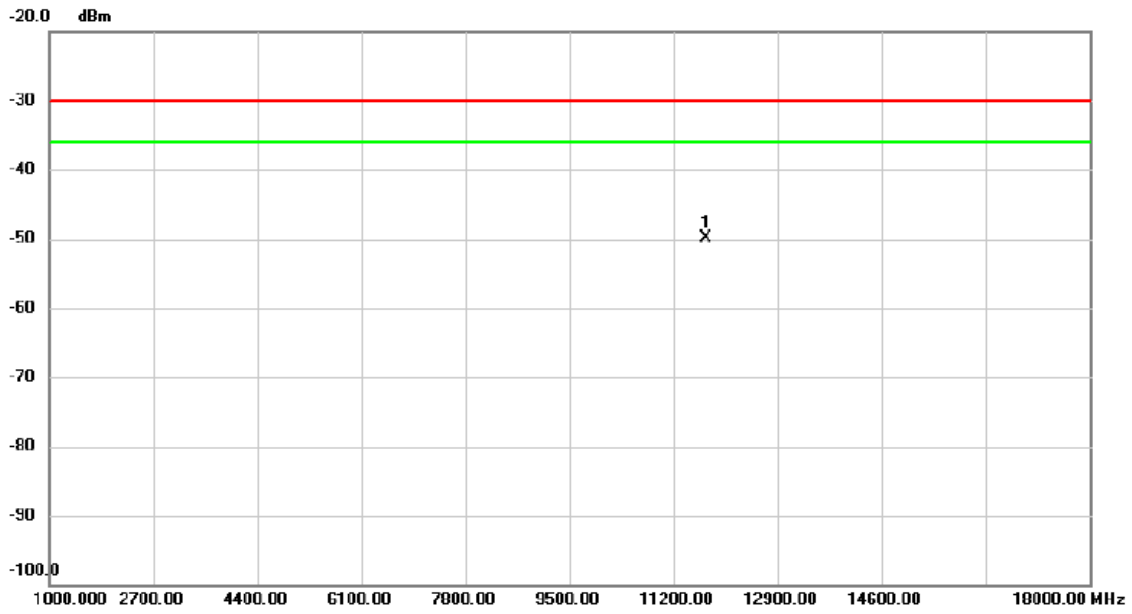

No. Mk.	Freq. MHz	Reading Level dBm	Correct Factor dB	Measure- ment dBm	Limit dBm	Margin dB	Detector	Comment
1 *	11724.450	-57.45	7.63	-49.82	-30.00	-19.82	peak	

Test Mode	TX IEEE 802.11ac(VHT20) Mode 5825 MHz	Polarization	Vertical
-----------	---------------------------------------	--------------	----------

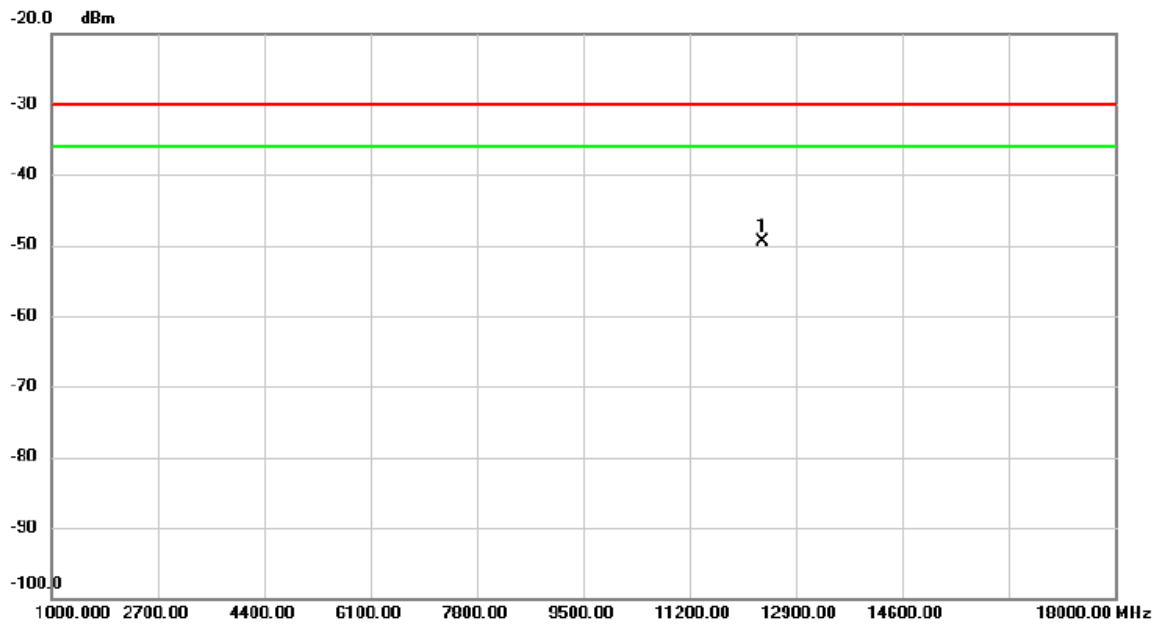

No.	Mk.	Freq. MHz	Reading Level dBm	Correct Factor dB	Measure- ment dBm	Limit dBm	Margin dB	Detector	Comment
1	*	12367.900	-58.13	8.60	-49.53	-30.00	-19.53	peak	

Test Mode	TX IEEE 802.11ac(VHT20) Mode 5825 MHz	Polarization	Horizontal
-----------	---------------------------------------	--------------	------------

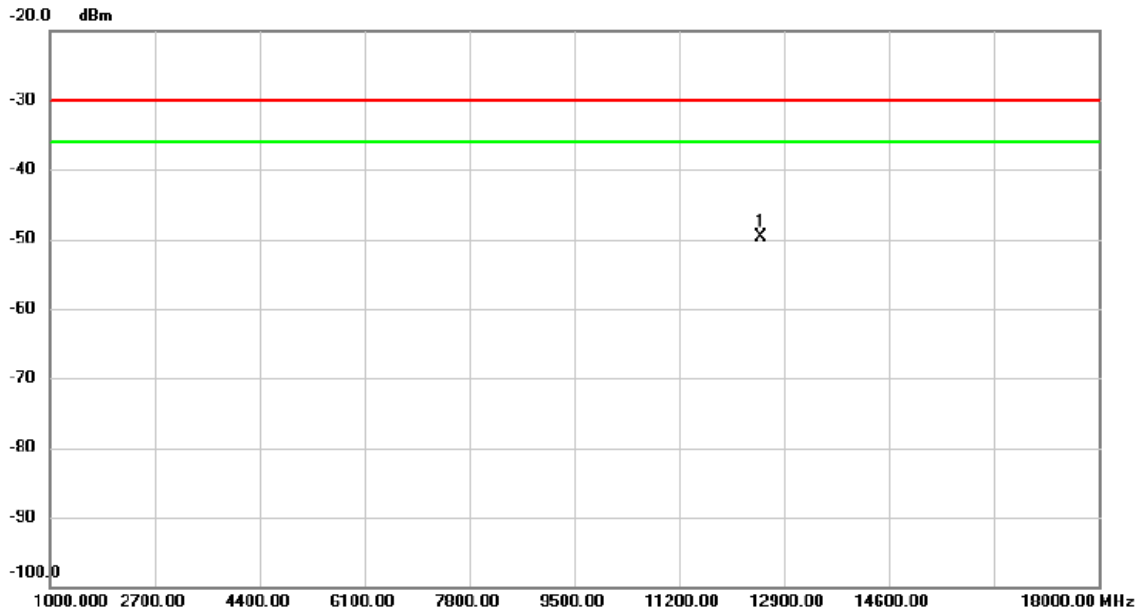

No.	Mk.	Freq. MHz	Reading Level dBm	Correct Factor dB	Measure- ment dBm	Limit dBm	Margin dB	Detector	Comment
1	*	12522.600	-58.56	8.89	-49.67	-30.00	-19.67	peak	

Test Mode	TX IEEE 802.11ac(VHT40) Mode 5755 MHz	Polarization	Vertical
-----------	---------------------------------------	--------------	----------

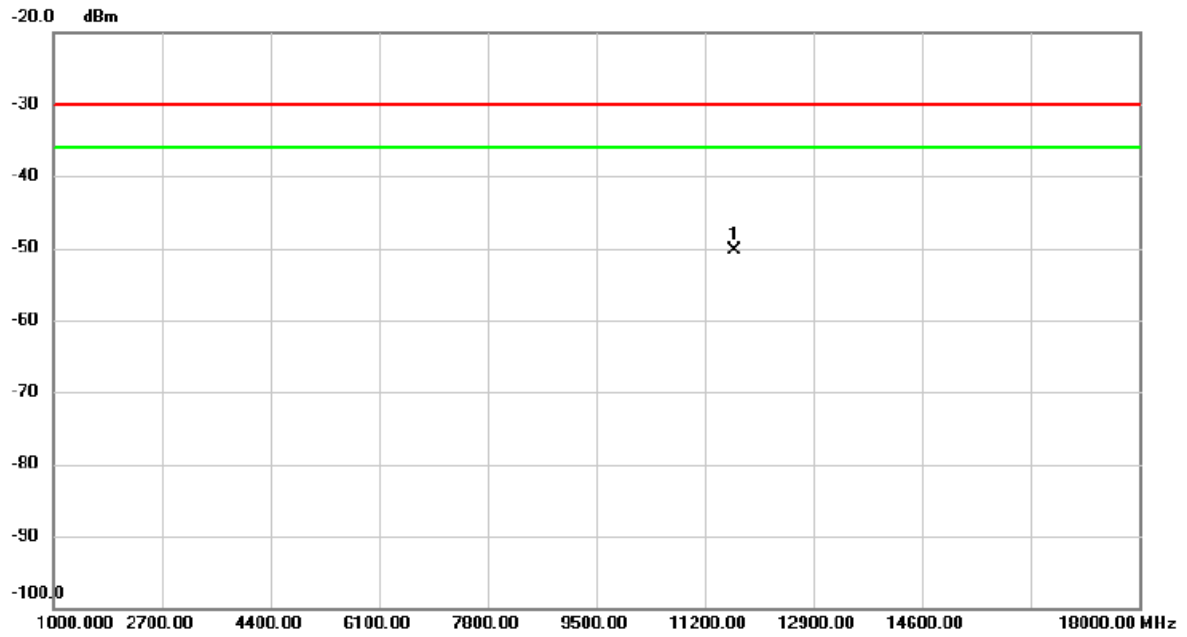

No. Mk.	Freq. MHz	Reading Level dBm	Correct Factor dB	Measure- ment dBm	Limit dBm	Margin dB	Detector	Comment
1 *	11659.850	-57.58	7.35	-50.23	-30.00	-20.23	peak	

Test Mode	TX IEEE 802.11ac(VHT40) Mode 5755 MHz	Polarization	Horizontal
-----------	---------------------------------------	--------------	------------

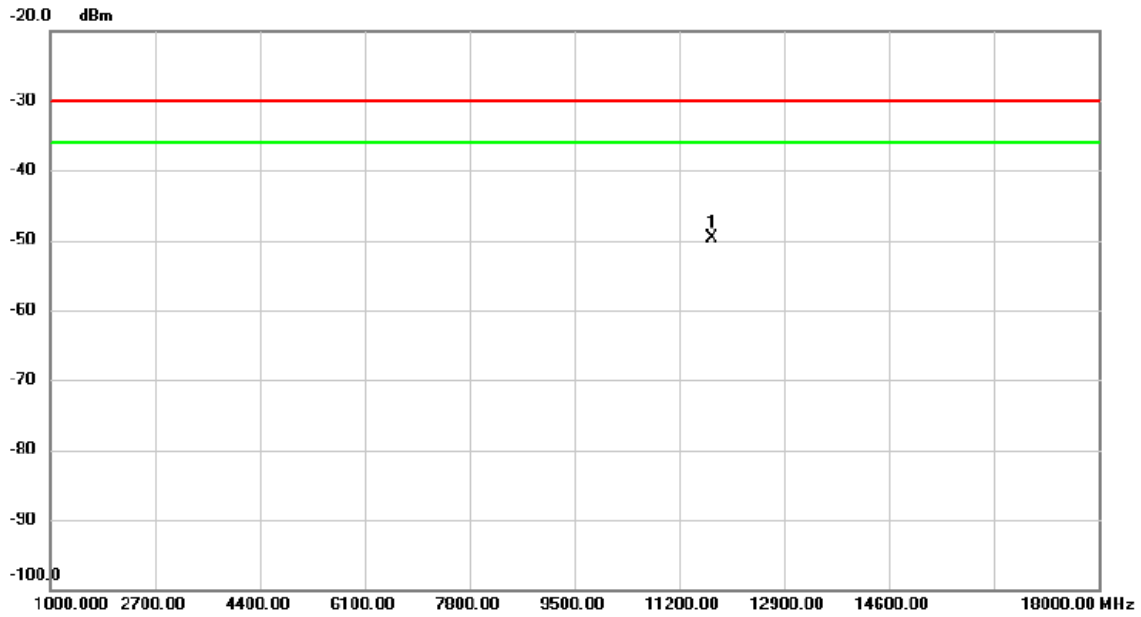

No. Mk.	Freq. MHz	Reading Level dBm	Correct Factor dB	Measure- ment dBm	Limit dBm	Margin dB	Detector	Comment
1 *	11732.950	-57.34	7.65	-49.69	-30.00	-19.69	peak	

Test Mode	TX IEEE 802.11ac(VHT40) Mode 5795 MHz	Polarization	Vertical
-----------	---------------------------------------	--------------	----------

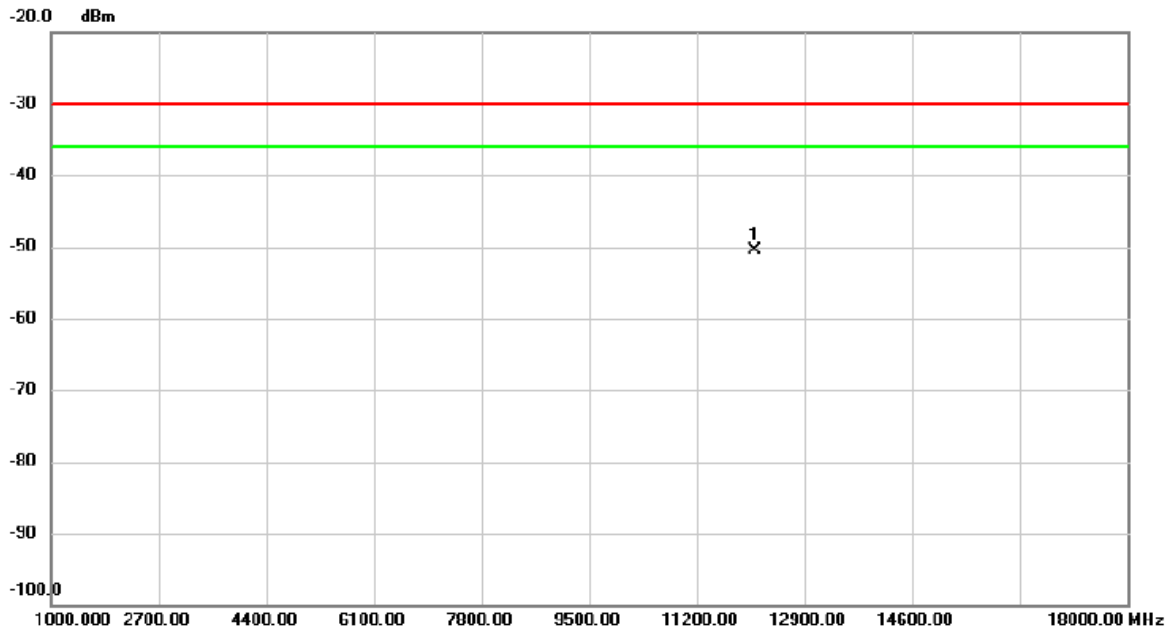

No.	Mk.	Freq. MHz	Reading Level dBm	Correct Factor dB	Measure- ment dBm	Limit dBm	Margin dB	Detector	Comment
1	*	12112.900	-58.61	8.19	-50.42	-30.00	-20.42	peak	

Test Mode	TX IEEE 802.11ac(VHT40) Mode 5795 MHz	Polarization	Horizontal
-----------	---------------------------------------	--------------	------------

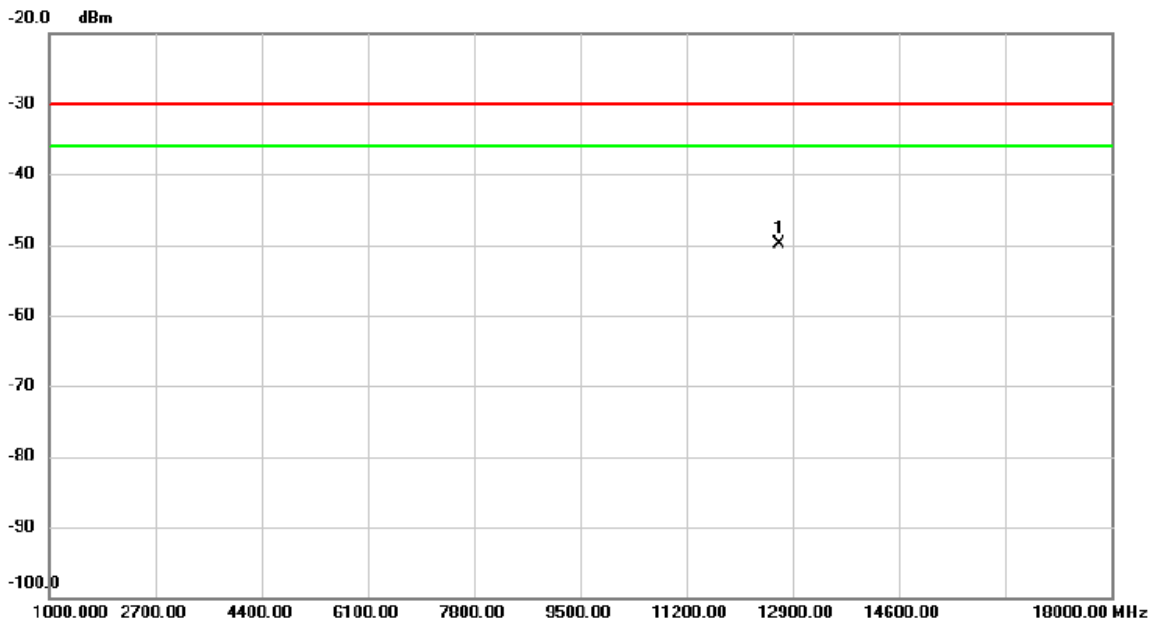

No.	Mk.	Freq. MHz	Reading Level dBm	Correct Factor dB	Measure- ment dBm	Limit dBm	Margin dB	Detector	Comment
1	*	12694.300	-58.38	8.43	-49.95	-30.00	-19.95	peak	

Test Mode	TX IEEE 802.11ac(VHT80) Mode 5775 MHz	Polarization	Vertical
-----------	---------------------------------------	--------------	----------

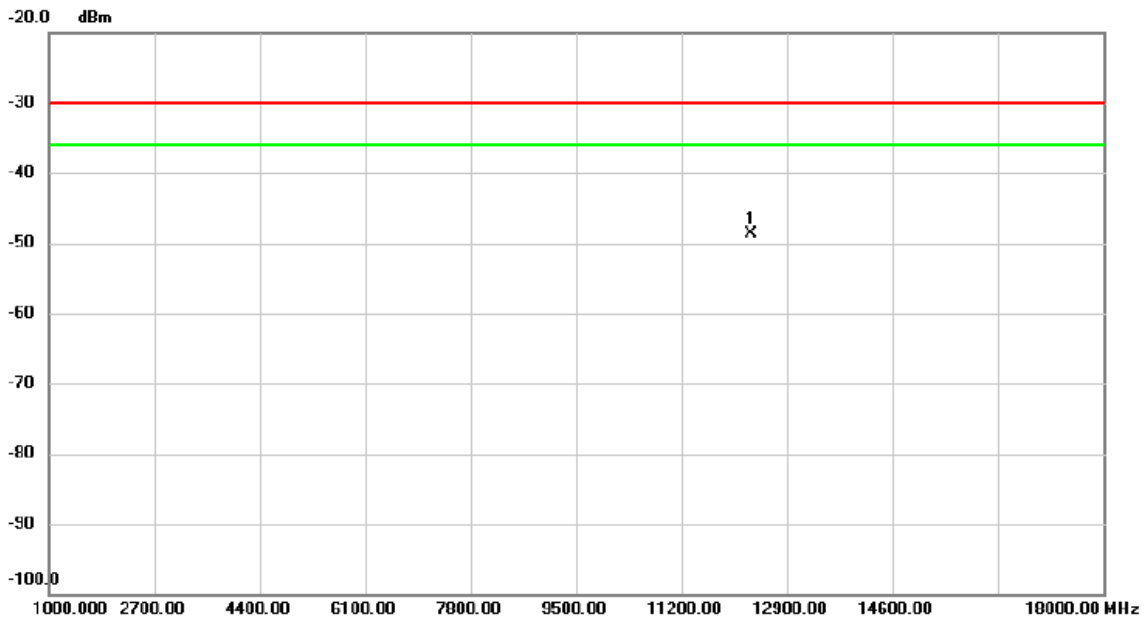

No.	Mk.	Freq. MHz	Reading Level dBm	Correct Factor dB	Measure- ment dBm	Limit dBm	Margin dB	Detector	Comment
1	*	12327.100	-57.27	8.54	-48.73	-30.00	-18.73	peak	

Test Mode	TX IEEE 802.11ac(VHT80) Mode 5775 MHz	Polarization	Horizontal
-----------	---------------------------------------	--------------	------------

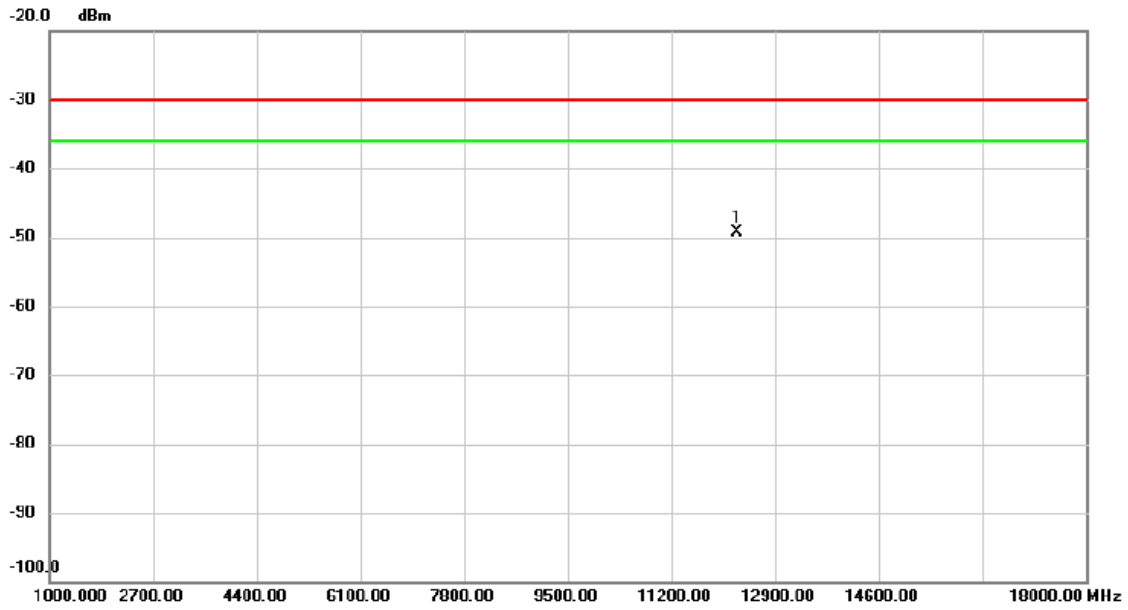

No. Mk.	Freq. MHz	Reading Level dBm	Correct Factor dB	Measure- ment dBm	Limit dBm	Margin dB	Detector	Comment
1 *	12284.600	-57.90	8.58	-49.32	-30.00	-19.32	peak	

Test Mode	TX IEEE 802.11ac(VHT20) Mode 5745 MHz	Polarization	Vertical
-----------	---------------------------------------	--------------	----------

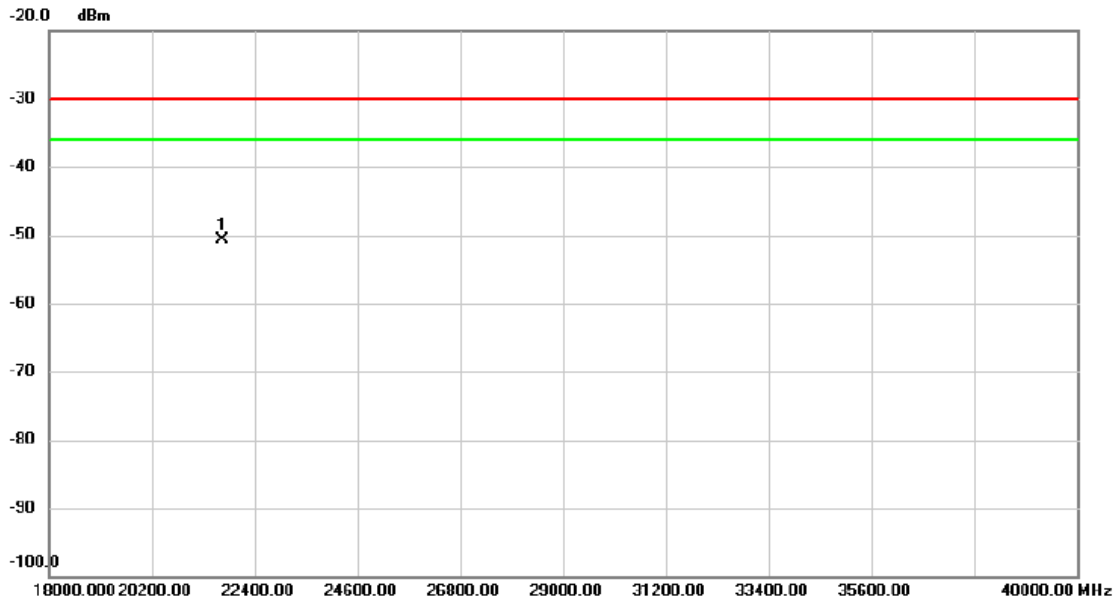

No. Mk.	Freq. MHz	Reading Level dBm	Correct Factor dB	Measurement dBm	Limit dBm	Margin dB	Detector	Comment
1 *	21705.900	-59.24	8.49	-50.75	-30.00	-20.75	peak	

Test Mode	TX IEEE 802.11ac(VHT20) Mode 5745 MHz	Polarization	Horizontal
-----------	---------------------------------------	--------------	------------

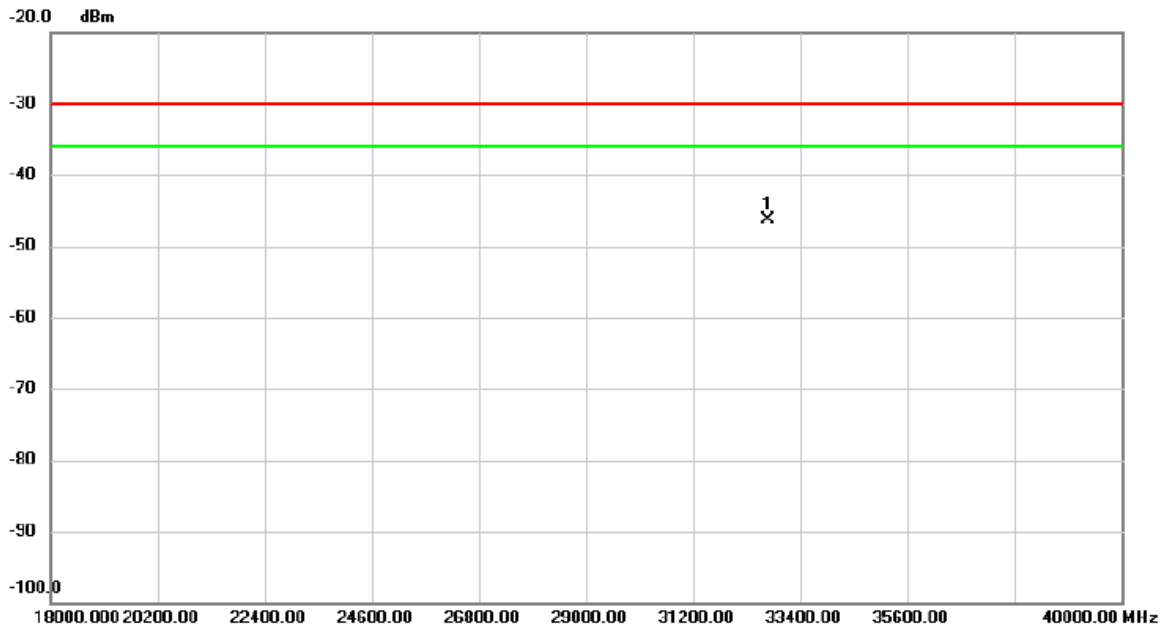

No.	Mk.	Freq. MHz	Reading Level dBm	Correct Factor dB	Measure- ment dBm	Limit dBm	Margin dB	Detector	Comment
1	*	32744.400	-55.76	9.47	-46.29	-30.00	-16.29	peak	

APPENDIX F - UNWANTED EMISSIONS IN THE SPURIOUS DOMAIN - STANDBY (ABOVE 1000MHZ)

Test Mode: N/A

Note: "N/A" denotes test is not applicable to this device.

APPENDIX G - DUTY CYCLE

Test Mode TX IEEE 802.11a Mode 5745 MHz

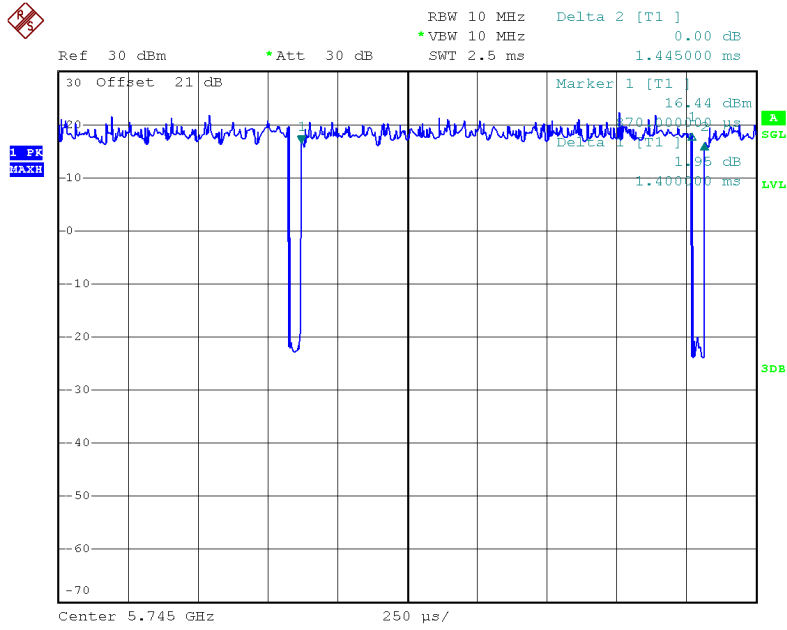

Date: 4.JUL.2024 20:32:49

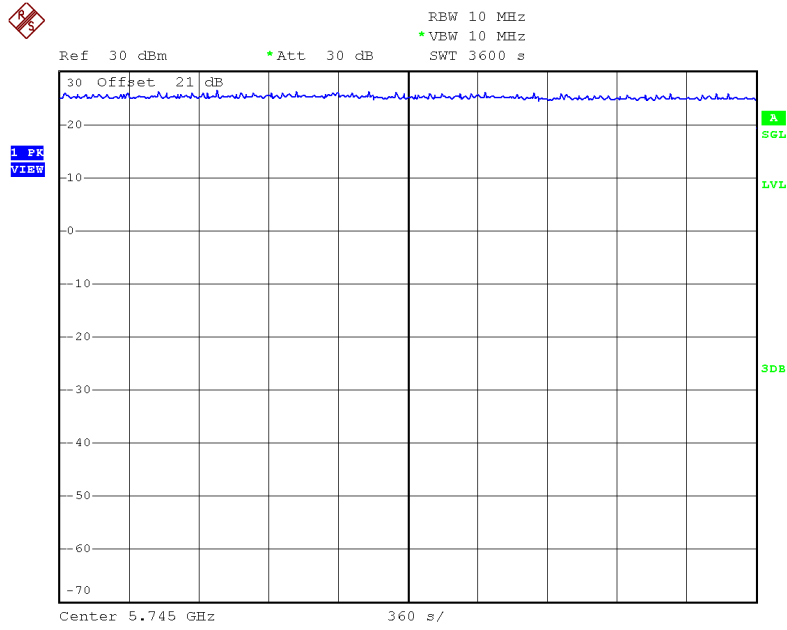

Date: 4.JUL.2024 21:03:57

On time (ms)	Total time (ms)	1H On time (s)	Duty Cycle (%)	Limit	Test Result
1.4	1.445	3600.00	96.89	No Restriction	Pass

APPENDIX H - ADJACENT CHANNEL SELECTIVITY

Test Mode	RX IEEE 802.11a Mode 5785 MHz
-----------	-------------------------------

Frequency (MHz)	99% OBW (MHz)				
5785	16.60				
Adjacent channel centre freq. (MHz)	k(-40<k<0) (dB)	Power level of unwanted signal (dBm)	Limit (dBm)	Result	
Lower	5765	-27.42	-45.00	-57.42	Complies
Upper	5805	-27.48	-45.00	-57.48	Complies

APPENDIX I - BLOCKING

Test Mode	RX IEEE 802.11a Mode 5745 MHz
-----------	-------------------------------

Frequency (MHz)	99% OBW (MHz)	99% OBW-FL (MHz)	99% OBW-FH (MHz)		
5745	16.60	5736.70	5753.30		
Times of OBW	Unwanted signal freq. (MHz)	k(-40<k<0) (dB)	Power level of unwanted signal (dBm)	Limit (dBm)	Result
10	5570.70	-27.12	-23.00	-57.12	Complies
	5919.30	-27.65	-23.00	-57.65	Complies
20	5404.70	-26.86	-22.00	-56.86	Complies
	6085.30	-27.89	-24.00	-57.89	Complies
50	4906.70	-26.02	-20.00	-56.02	Complies
	6583.30	-28.57	-21.00	-58.57	Complies

Test Mode	RX IEEE 802.11a Mode 5825 MHz
-----------	-------------------------------

Frequency (MHz)	99% OBW (MHz)	99% OBW-FL (MHz)	99% OBW-FH (MHz)		
5825	16.60	5816.70	5833.30		
Times of OBW	Unwanted signal freq. (MHz)	k(-40<k<0) (dB)	Power level of unwanted signal (dBm)	Limit (dBm)	Result
10	5650.70	-27.24	-24.00	-57.24	Complies
	5999.30	-27.76	-23.00	-57.76	Complies
20	5484.70	-26.98	-22.00	-56.98	Complies
	6165.30	-28.00	-25.00	-58.00	Complies
50	4986.70	-26.16	-21.00	-56.16	Complies
	6663.30	-28.67	-22.00	-58.67	Complies

APPENDIX J - SPURIOUS EMISSIONS - RECEIVER (25MHZ TO 1000MHZ)

Test Mode	RX IEEE 802.11ac(VHT20) Mode 5745 MHz	Polarization	Vertical
-----------	---------------------------------------	--------------	----------

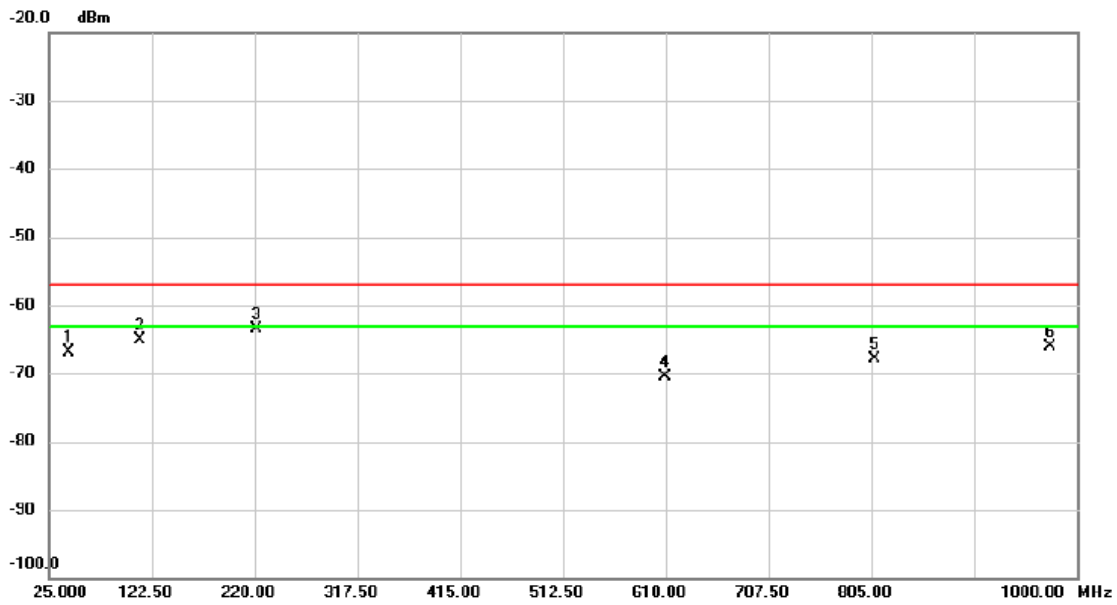

No.	Mk.	Freq. MHz	Reading Level dBm	Correct Factor dB	Measure- ment dBm	Limit dBm	Margin dB	Detector	Comment
1		43.720	-67.55	0.64	-66.91	-57.00	-9.91	peak	
2		111.873	-61.60	-3.52	-65.12	-57.00	-8.12	peak	
3	*	221.852	-60.64	-2.82	-63.46	-57.00	-6.46	peak	
4		609.025	-75.59	5.00	-70.59	-57.00	-13.59	peak	
5		808.705	-75.72	7.83	-67.89	-57.00	-10.89	peak	
6		974.553	-75.67	9.59	-66.08	-57.00	-9.08	peak	

Test Mode	RX IEEE 802.11ac(VHT20) Mode 5745 MHz	Polarization	Horizontal
-----------	---------------------------------------	--------------	------------

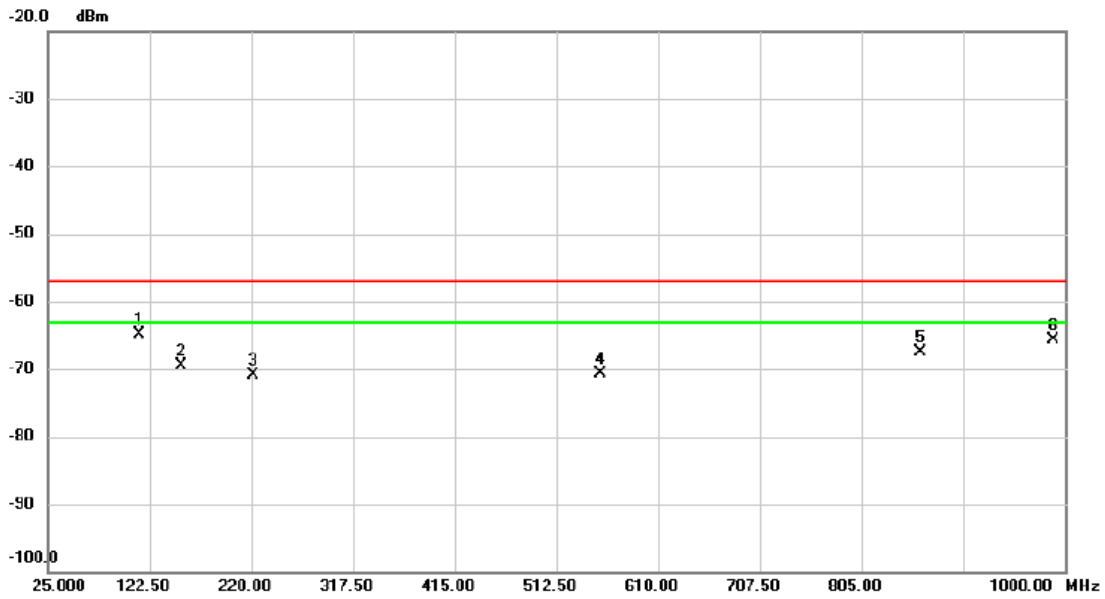

No.	Mk.	Freq. MHz	Reading Level dBm	Correct Factor dB	Measure- ment dBm	Limit dBm	Margin dB	Detector	Comment
1	*	112.555	-60.86	-4.08	-64.94	-57.00	-7.94	peak	
2		153.213	-70.26	0.81	-69.45	-57.00	-12.45	peak	
3		221.852	-68.66	-2.22	-70.88	-57.00	-13.88	peak	
4		554.620	-74.64	4.03	-70.61	-57.00	-13.61	peak	
5		860.965	-75.20	7.74	-67.46	-57.00	-10.46	peak	
6		989.178	-75.67	10.06	-65.61	-57.00	-8.61	peak	

Test Mode	RX IEEE 802.11ac(VHT20) Mode 5825 MHz	Polarization	Vertical
-----------	---------------------------------------	--------------	----------

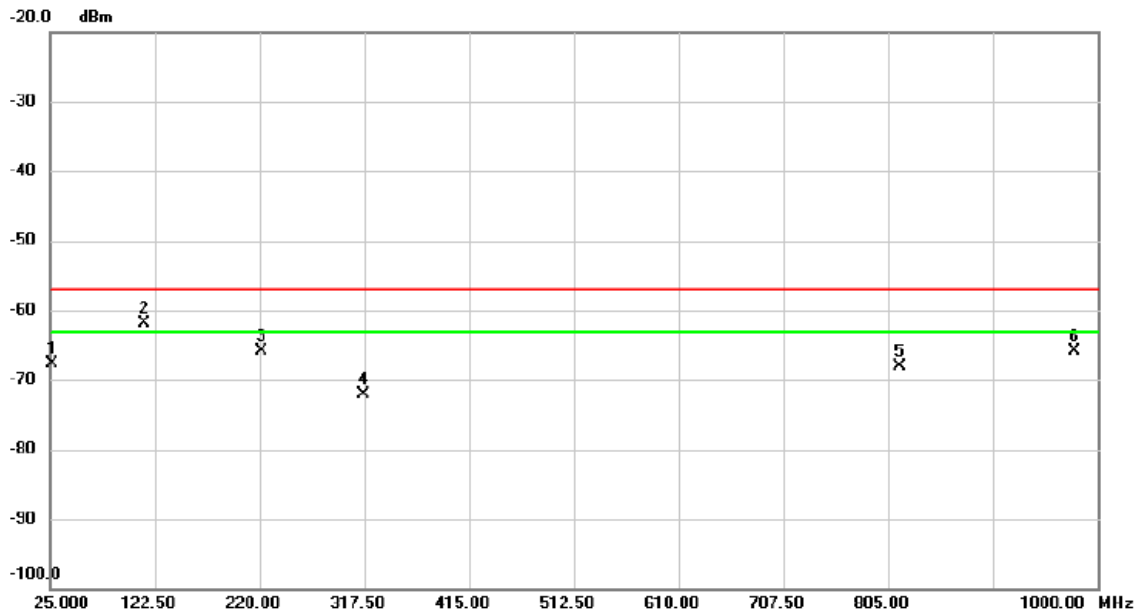

No.	Mk.	Freq. MHz	Reading Level dBm	Correct Factor dB	Measurement dBm	Limit dBm	Margin dB	Detector	Comment
1		26.365	-68.85	1.09	-67.76	-57.00	-10.76	peak	
2	*	112.555	-58.51	-3.46	-61.97	-57.00	-4.97	peak	
3		221.950	-63.05	-2.80	-65.85	-57.00	-8.85	peak	
4		316.915	-71.65	-0.37	-72.02	-57.00	-15.02	peak	
5		816.212	-75.83	7.74	-68.09	-57.00	-11.09	peak	
6		979.135	-75.44	9.60	-65.84	-57.00	-8.84	peak	

Test Mode	RX IEEE 802.11ac(VHT20) Mode 5825 MHz	Polarization	Horizontal
-----------	---------------------------------------	--------------	------------

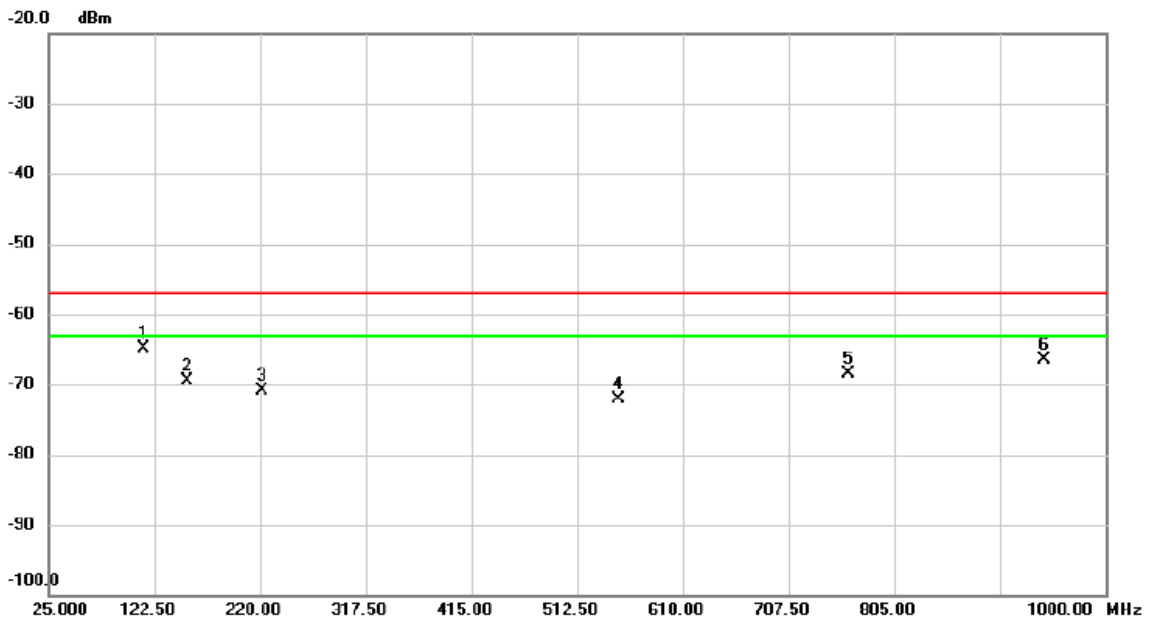

No.	Mk.	Freq. MHz	Reading Level dBm	Correct Factor dB	Measure- ment dBm	Limit dBm	Margin dB	Detector	Comment
1	*	112.555	-60.86	-4.08	-64.94	-57.00	-7.94	peak	
2		153.213	-70.26	0.81	-69.45	-57.00	-12.45	peak	
3		221.852	-68.70	-2.22	-70.92	-57.00	-13.92	peak	
4		550.622	-76.01	3.97	-72.04	-57.00	-15.04	peak	
5		762.782	-75.36	6.82	-68.54	-57.00	-11.54	peak	
6		943.742	-75.96	9.39	-66.57	-57.00	-9.57	peak	

APPENDIX K - SPURIOUS EMISSIONS - RECEIVER (ABOVE 1000MHZ)

Test Mode	RX IEEE 802.11ac(VHT20) Mode 5745 MHz	Polarization	Vertical
-----------	---------------------------------------	--------------	----------

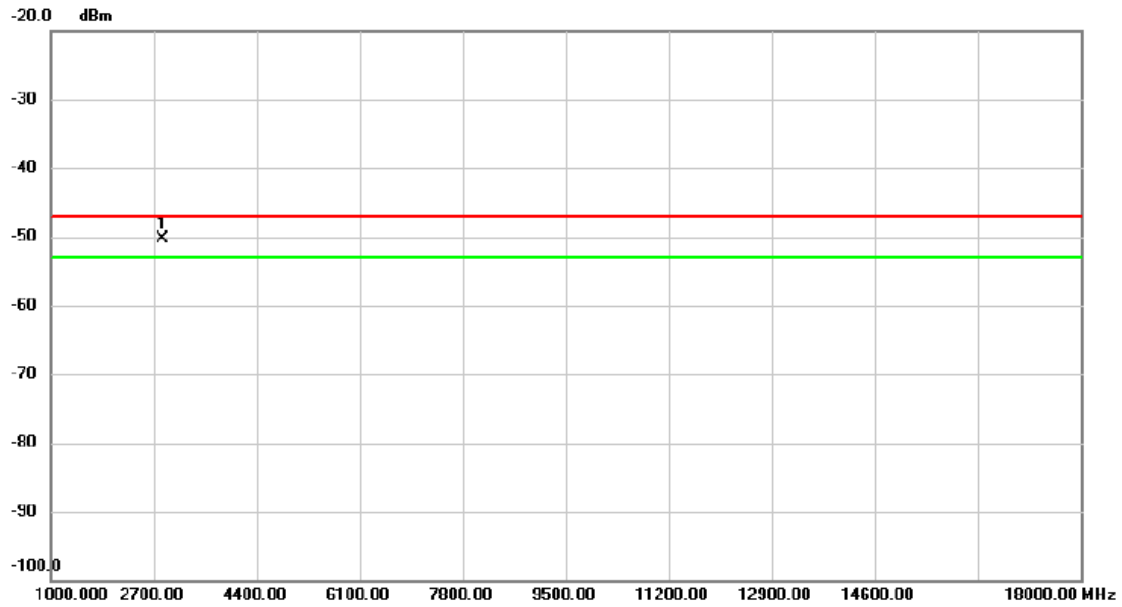

No.	Mk.	Freq. MHz	Reading Level dBm	Correct Factor dB	Measure- ment dBm	Limit dBm	Margin dB	Detector	Comment
1	*	2850.450	-47.79	-2.46	-50.25	-47.00	-3.25	peak	

Test Mode	RX IEEE 802.11ac(VHT20) Mode 5745 MHz	Polarization	Horizontal
-----------	---------------------------------------	--------------	------------

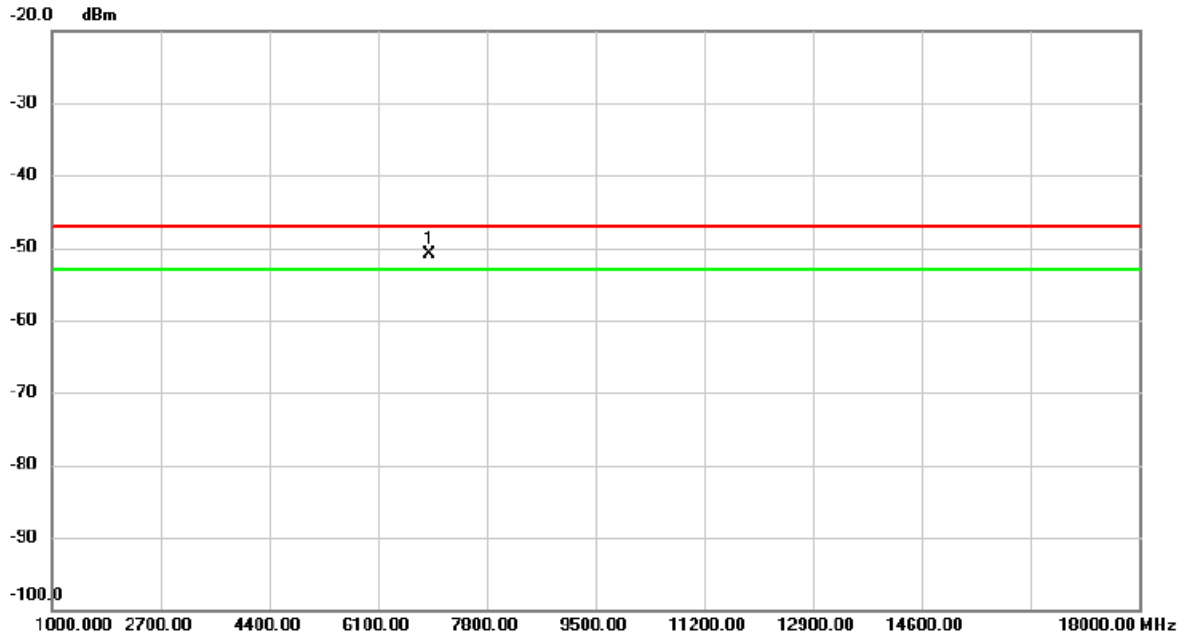

No.	Mk.	Freq. MHz	Reading Level dBm	Correct Factor dB	Measure- ment dBm	Limit dBm	Margin dB	Detector	Comment
1	*	6896.450	-51.59	0.72	-50.87	-47.00	-3.87	peak	

Test Mode	RX IEEE 802.11ac(VHT20) Mode 5825 MHz	Polarization	Vertical
-----------	---------------------------------------	--------------	----------

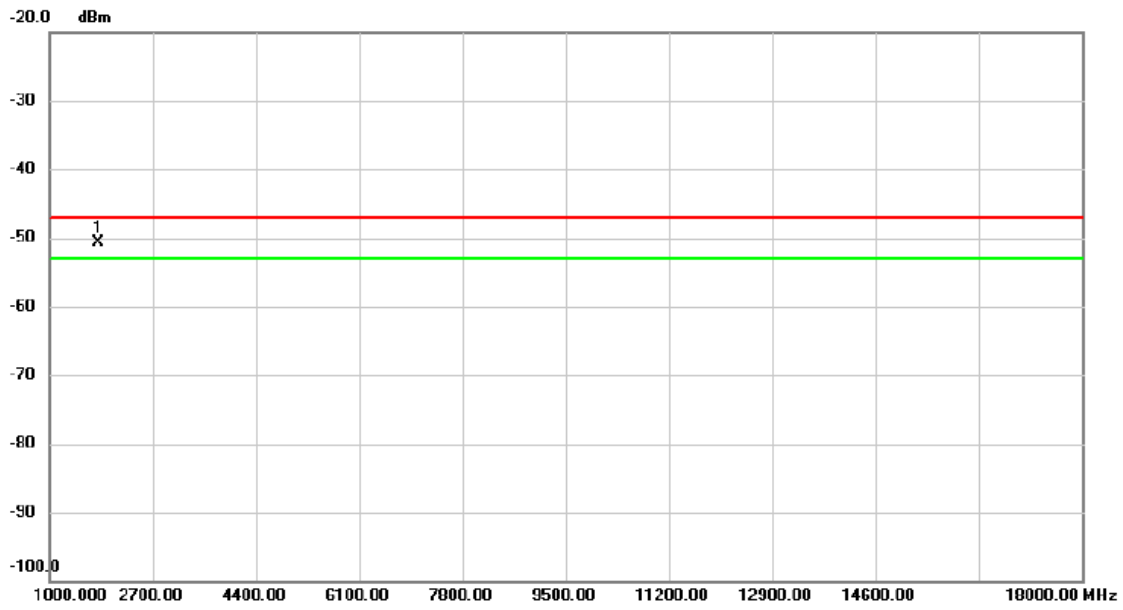

No.	Mk.	Freq. MHz	Reading Level dBm	Correct Factor dB	Measure- ment dBm	Limit dBm	Margin dB	Detector	Comment
1	*	1815.150	-42.77	-7.85	-50.62	-47.00	-3.62	peak	

Test Mode	RX IEEE 802.11ac(VHT20) Mode 5825 MHz	Polarization	Horizontal
-----------	---------------------------------------	--------------	------------

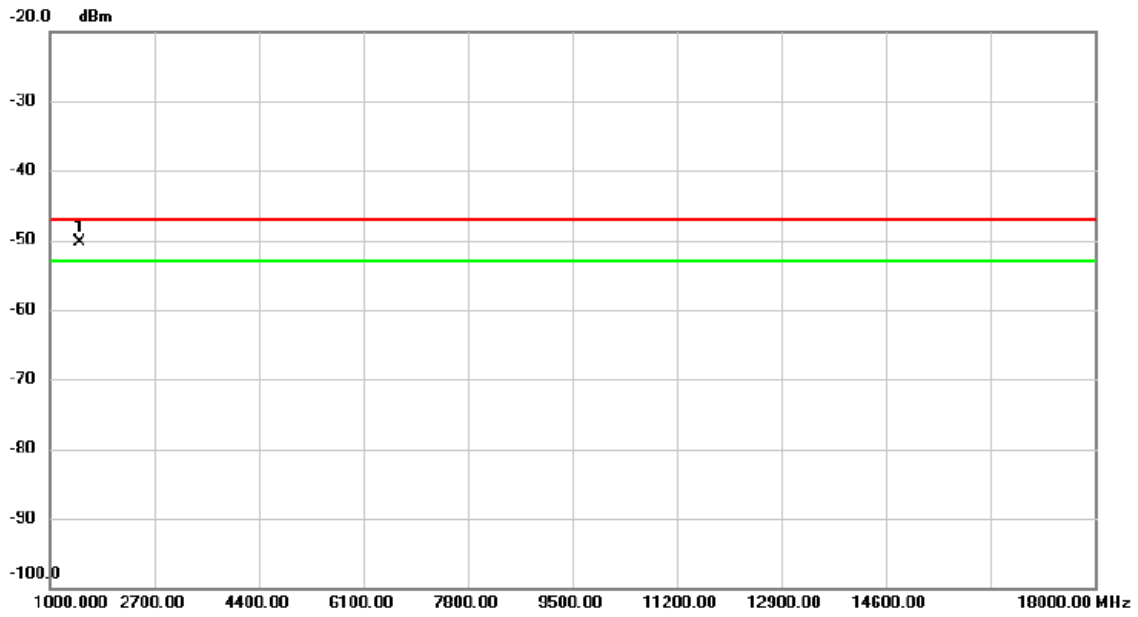

No.	Mk.	Freq. MHz	Reading Level dBm	Correct Factor dB	Measure- ment dBm	Limit dBm	Margin dB	Detector	Comment
1	*	1479.400	-40.18	-10.21	-50.39	-47.00	-3.39	peak	

Test Mode	RX IEEE 802.11ac(VHT20) Mode 5745 MHz	Polarization	Vertical
-----------	---------------------------------------	--------------	----------

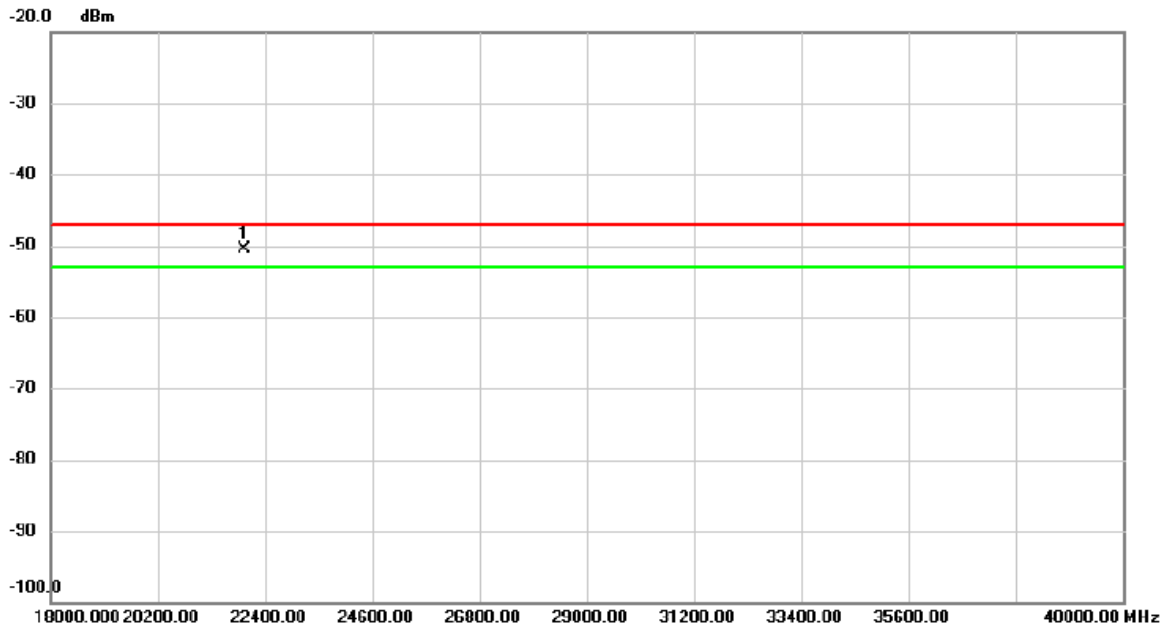

No.	Mk.	Freq. MHz	Reading Level dBm	Correct Factor dB	Measure- ment dBm	Limit dBm	Margin dB	Detector	Comment
1	*	21966.600	-59.51	8.97	-50.54	-47.00	-3.54	peak	

Test Mode	RX IEEE 802.11ac(VHT20) Mode 5745 MHz	Polarization	Horizontal
-----------	---------------------------------------	--------------	------------

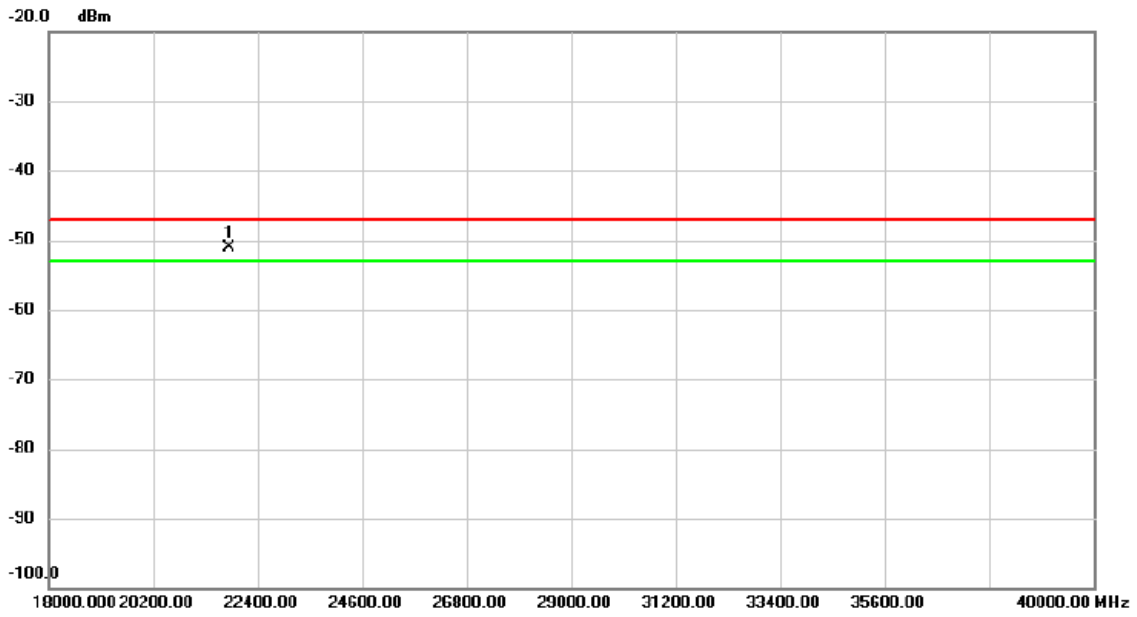

No. Mk.	Freq. MHz	Reading Level dBm	Correct Factor dB	Measurement dBm	Limit dBm	Margin dB	Detector	Comment
1 *	21803.800	-58.98	7.87	-51.11	-47.00	-4.11	peak	

End of Test Report